

KESNOS

Commercial Dehumidifier

Please read the manual carefully
before using the unit

PD606A

USER MANUAL

FOR CUSTOMERS

Thank you for purchasing our dehumidifier.

Kesnos wishes that our products and services can bring convenience to your work and life. We highly recommend that you keep the manual for reference if you encounter unexpected events using the unit. Please read the manual carefully to ensure the proper use of the dehumidifier.

Our company's dehumidifiers are widely used in home or work area.

The dehumidifier from **Kesnos** operates quickly and efficiently to reduce room's humidity and bring you a healthy and comfortable life.

To Access Customer Support Faster

If there is any problem of the product, please contact Kesnos Customer Service at support@kesnos.com with your purchase Order ID to help us address the problem faster.

BEFORE FIRST USE:

To prevent any internal damage, it is very important to keep refrigeration units (like this one) upright throughout their journey. Please leave it standing upright and outside the box for **24 HOURS** before plugging it in.

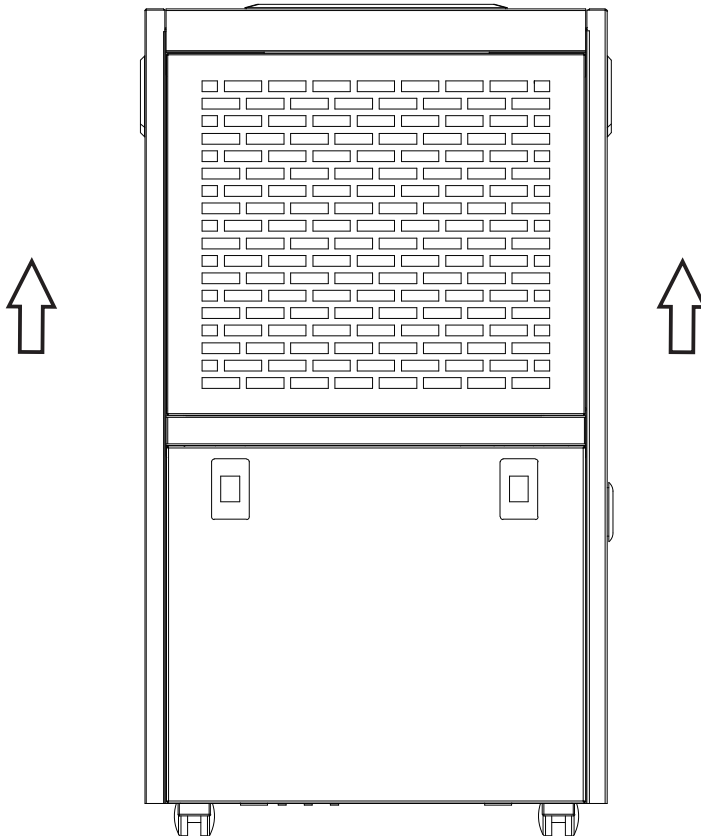

CATALOG

Precaution for Use.....	01
Product Instructions	02
Operation Instructions.....	03
Parts Descriptions.....	06
Specification.....	07
Malfunction Code.....	08
Safety Operation and Protection.....	09
Maintenance and Repair.....	11
Malfunction and Troubleshooting.....	12
Warranty and Contact Us.....	13

Statement

The graphics and functions provided in this manual may not be the same as the actual product. Please always refer to the actual product. The model of the machine on the manual is for reference only. Please operate the machine based on the actual product. The right to interpret the relevant terms belongs to the company.

PRECAUTIONS FOR USE

Safety notes:

Before installation, operation and maintenance of this machine, please read the safety precautions carefully.

Remove the packing materials of the device, keep far away from kids or baby to avoid the risk of suffocation.

Before plug in the machine, ensure the voltage is within the range of label.

This dehumidifier is only used for the specified applications.

The manufacturer shall not take any responsibility for the damage caused by the improper application.

This device is safe in application, but careful operation is required as operating other electric appliances.

Please place the machine vertically for two hours prior to power on the machine in the 1st time application.

Cautions!

- Indoor application only.
- Adopt 110-120V-60Hz grounding socket.
- Observe the local regulations for the installation and applications.
- Learn more or consult professional for any question on the installation.
- Draw out the plug when do not use. Never remove the plug by pulling the wire.
- Never operate the part by wet hand.
- Keep away from the touch of the kids.
- Do not soak the parts into water or spray water directly on the part during cleaning.
- When using dehumidifier , other objects surrounding the machine at least need to keep a distance of 39.4inches(1m).
- Draw the plug out before cleaning the device or any part of the machine.
- Draw out the plug when changing the filter trap.
- Do not use the extension cable to connect with power; ask professional for the installation when there are no proper socket available.
- Use on Single Outlet Circuit Only.

To avoid the occurrence of danger, ask manufacturer, agents or qualified staff for the replacement of damaged power wire.

1. Product Introduction

Dehumidifier is used for reducing the air moisture of its installation space to a proper level, so as to fit people in the daily life and material storage.

Beautiful in shape, compact in size, convenient in operation, this dehumidifier is widely used in the dehumidification of many sites with high moisture such as scientific researching, medical & health care, commodity storage, underground engineering, so as to prevent the loss caused by moisture, rust, decomposition of apparatus, devices, telecommunications devices, medicines, files etc.

As considering the setting optimum humidity of the climate and environment change, physiological health condition of human, protection condition of indoor furniture and other Items varies between 45% to 65%, it is suggested to set the humidity within this range.

2. Product features

- (1) Beautiful appearance, high grade, compact and reasonable structure, firm
- (2) Easy to operate, special timing function
- (3) General low temperature application, high efficiency automatic haze system
- (4) Unique humidity 1% adjustable setting function
- (5) Hose continuous drainage function
- (6) Special environment temperature display, temperature display and automatic fault diagnosis function
- (7) Some models are equipped with universal wheels at the bottom, which can move freely
- (8) Adopt international famous brand compressor, international famous brand humidity sensor

OPERATION INSTRUCTIONS

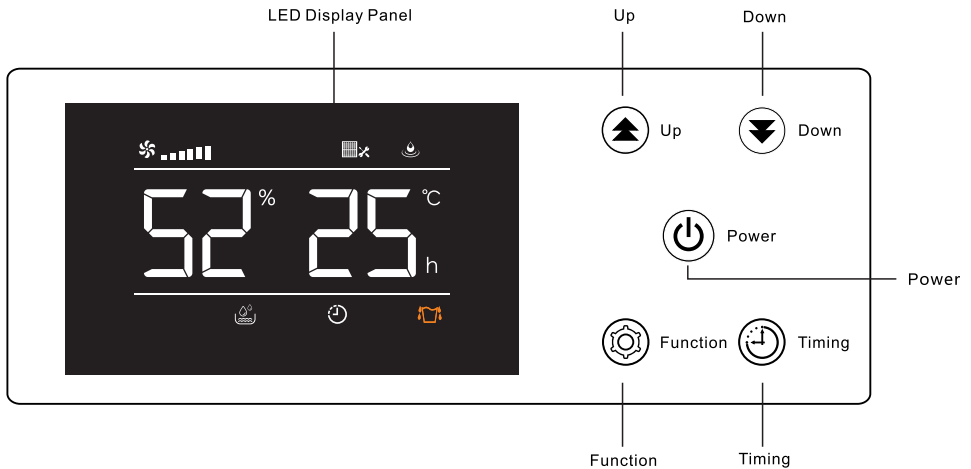

Button Description

1) Power Button: In the status of power off, press this button to turn on the device and vice versa (In the status of power on, the LED screen will light up and vice versa).

Note: Dark button set not mean the power is disconnected.

2) Up/Down Button: Set to increase/decrease for humidity or function.

3) Timing Button: Long press to enter timing setting, short press to confirm parameter setting.

4) Function Button: To confirm the setting

Humidity Setting

In the status of power on, press UP/DOWN button to set the humidity value range between 10% to 98%. Press the Function Button one time or no any pressing on the Buttons for 10 seconds, the dehumidifier will exist the function setting automatically.



OPERATION INSTRUCTIONS



Timing Settings

In the power on or standby state, press the **"Timing"** button once to enter the timing setting state: Indicator Timing light, the unit of time is bright, small number **77** flashes to show the time. In the timing setting state, press the **"Up"** or **"Down"** button to set the desired time, setting range 01~24h, can be cycled. Pressing the **"Function"** button once or no button operation for a few seconds, the timing setting state is automatically exited.

If the time is set to 00, the timing setting is invalid.

Status Description

When the fan is delayed, the running symbol  will flash, and if the fan is running, the running symbol  will be on, otherwise it will be off;

When the compressor is delayed, the dehumidification symbol  will flash, and if the compressor is running, the dehumidification symbol  will be on, otherwise it will be off;

If the ambient humidity is lower than the set humidity and the compressor is stopped, the humidity control symbol  will flash, otherwise it will be off;

When the machine needs to be cleaned, the cleaning symbol  flashes, otherwise it is off;

When the machine is defrosting, the defrost symbol  flashes, defrosting end the light goes out;

OPERATION INSTRUCTIONS

Power off Memory Function

After the device is powered on, it will automatically resume the working status before power off.



Defrost Function

When frost builds up on the evaporator coils, the compressor will cycle off and the fan will continue to run until the frost disappears.

Temperature Protection Function

When the ambient temperature is higher than the default temperature 113°F, the system enters high temperature protection, the small number indicates "HH", and the compressor stops; When the ambient temperature is lower than the default temperature 39 °F), the system enters the low temperature protection, the small number indicates "LL", and the whole machine stops.

Cleaning Remind Function

If the accumulative running time of the fan is ≥ 30 days, the machine can continue to run, but it will prompt “ ” and it will not be able to be removed even re-powered. In the power off state, long press the “Function” button for a few seconds, then the display will show one time, the “ ” prompt will be released, and the fan running time will be cleared.

Special Note:

To avoid any damage to the dehumidifier, the dehumidifier will not start operation following a complete cycle until after 3 minutes. The compressor will automatically start after 3 minutes.

PARTS
DESCRIPTIONS

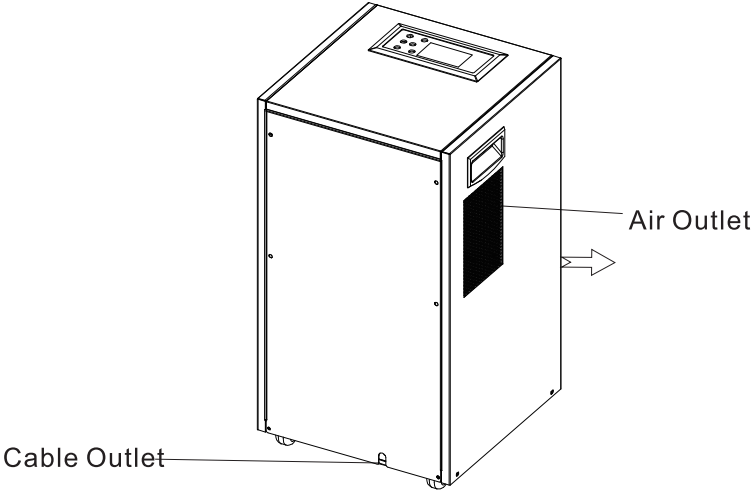
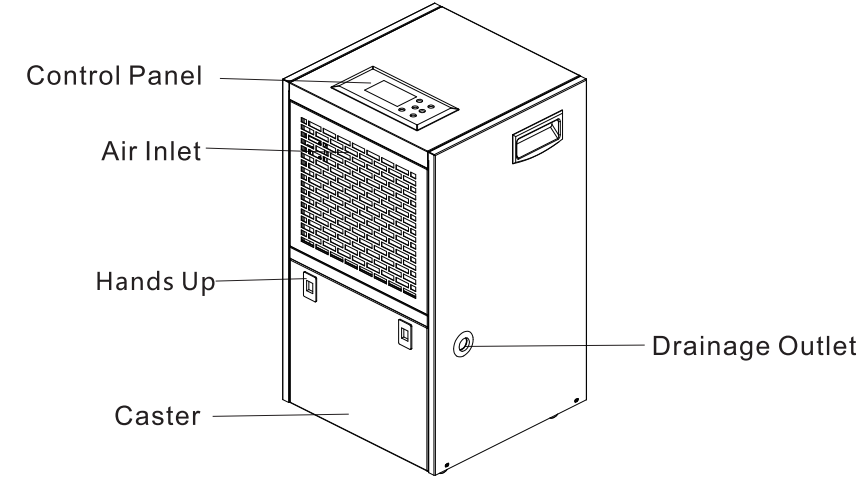

Note: This picture shows the dehumidifier Outline Drawing.
Other models shape and size are a little different, please prevail In kind.

SPECIFICATION

MODEL	PD606A
POWER SOURCE	120V ~ 60Hz
RATED POWER(95°F,90%RH)	1000W
RATED CURRENT(95°F,90%RH)	8.8A
MOISTURE REMOVAL CAPACITY (65°F,60%RH)	48.7 Pints/Day(23L/Day)
MOISTURE REMOVAL(80 °F,60%RH)	74 Pints/Day(35.3L/Day)
MOISTURE REMOVAL(86 °F,80%RH)	123 Pints/Day(58.5L/Day)
MOISTURE REMOVAL(95 °F,90%RH)	155 Pints/Day(73.4L/Day)
INPUT POWER(65°F,60%RH)	515W
INPUT CURRENT(65°F,60%RH)	4.6A
IEF(65°F,60%RH)	1.80 liters/kWh
MOTOR FLA	0.85A
MOTOR COMPRESSOR	RLA:10A LRA:30A
REFRIGERANT	R410A/15.87ozs(450g)
MAXIMUM ALLOWABLE PRESSURE	800PSIG(5.5MPa)
HIGH PRESSURE	580PSIG(4.0MPa)
LOW PRESSURE	247PSIG(1.7MPa)

Working temperature range from 41°F (5°C) or higher 95°F (35°C). In the event of the room temperature exceed this range; this part will not work properly.

The parts parameters of above are subject to modification without further notice.

⚠ WARNING:
 This product can expose you to chemicals including Styrene and its compounds, which is known to the State of California to cause cancer and birth defects or other reproductive harm. For more information go to: www.P65Warnings.ca.gov

MALFUNCTION CODE

Malfunction Codes	Description
E0	Malfunction of defrosting temperature sensor 2
E1	Malfunction of humidity sensor
E2	Malfunction of defrosting temperature sensor 1
E3	Malfunction of phase sequence (reverse phase or lack phase)
E4	Malfunction of environmental temperature sensor
E5	Malfunction of system high pressure
E6	Malfunction of system low pressure
E7	Alarm for full water
E8	Malfunction of overloading current of compressor
E9	Malfunction of overloading current of air blower
ER(EA)	Defrost temperature sensor 3 failure
Eb (Eb)	Defrost temperature sensor 4 failure
Ec (Ec)	Display information transmission abnormal

Note:

- 1.If display E0 E1 E2 E3 E4 ER or Eb fault, compressors, fans were still working, only alarm and display fault code, turn off the electricity power then turn on still can start (a few seconds for the alarm sound, press any button to reset the alarm sounds).
- 2.E3 E5 E6 E8 E9 alarms, troubleshooting, need power off, then power on, the alarm will relieve.
- 3.When E2 fails, the operation of the machine is not controlled by the operation panel.
- 3.If the malfunction is still present, please don't hesitate to contact Kesnos Customer Service email: support@kesnos.com for help.

SAFETY OPERATION AND PROTECTION

Do not use overall relay, extension cable or adaptor to connect this device. Wrong application could cause fire, electric shock or heating.

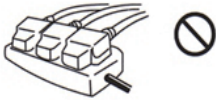

Do not place this device close to furnace, heater and devices that could produce heat. Wrong application could cause the resin be melt and even cause fire.

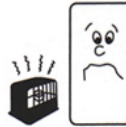

Do not use the machine in the area that is subject to direct sunlight or wind or rain. Indoor application only.



Furn off the machine and remove the power wire when problem happens[e.g. the machine emits the smell of burning]. Wrong application could result in fire. Electric shock and new failure.



Do not use the machine in the area that could be affected by chemical. The medicine or solvent permeated into the air could cause bad influence to the device and cause leakage of water in the tank.



Remove the power cable when do not use the machine for a long time.



Turn off the machine and remove the power cable firstly when cleaning the machine. Improper operation cause personal injury.



Place the drain hose well when use continuously draining so as to pass the water freely In the water event of cold temperature around the pipe could freeze, do not drain water continuously.



SAFETY OPERATION AND PROTECTION

Do not repair, disassemble or modify this machine through do-it-yourself.

Wrong application could cause fire or accident of electric shock.



Place this machine in stable site.

In the event of turn the device upside down, the water could pour out and damage the surrounding items, and cause electric leakage and fire or electric shock.



The method to lengthen the application life of air purification filtering mesh
Place the filtering mesh into plastic bag when do not use the device for a long time, seal and store.



Do not use this machine in the area that is adjacent to water.

As electric leakage could happen when this machine encounters water and will cause fire or electric shock.



Apply proper power switch.
Wrong application could cause fire or electric shock.



Do not damage or alter power cable. Please do not place heavy item on the power cable, heat or pull the power cable with force, or it could damage the power cable and cause fire or electric shock.



Connect the power cable with the switch securely.
In the event of looseness of power cable, there are could be danger of electric shock.



Do not draw out power cable to stop the operation of dehumidifier.
Wrong application could cause fire or electric shock.



MAINTENANCE AND REPAIRING

Before cleaning and maintenance, draw out the power cable of the cleaning or at least one time per month or before storage.

Do not use detergent, steel wire ball, chemical treated dust removing cloth, gasoline, benzene, thinner or other solvents for the cleaning as these items could damage the machine body.

Cleaning filter trap

This device is equipped with a filter trap that can be washed, by which this machine can isolate large part of the contaminants transmitted through air, such as dust, smoke, animal fur, mold spore and pollen, reduce the substances that could cause sensitization.

It is suggested to check the filtering mesh regularly, make the cleaning or at least one time per month or before storage.

- Get out the filter trap
- Remove the contaminant in the filter trap by dust cleaner.
- If the filter trap is extreme dirty, use the warm water and soft cleaner for the cleaning, air dry the part thoroughly. Do not expose the part to direct sunlight or use other heating device for baking, as this could deform the filter trap body and its frame.
- Equip the filter trap in the device after cleaning. This dehumidifier will drain water continuously. Please follow the setting of manual for the continual draining.

This dehumidifier will drain water continuously. Please follow the setting of manual for the continual draining.

1. The device is attached with one drainpipe; see the drainpipe in the diagram.
2. Ensure no bending in the drainpipe for smooth water flow.

User shall never repair or disassemble this parts through do-it-yourself, improper repairing could endanger the user's body.

MAIFUNCTION AND TROUBLESHOOTING

Malfunction	Cause	Solution
The dehumidifier do not operate	<ol style="list-style-type: none"> 1. Power failure 2. Switch is not connected 3. Plug is not inserted into socket 4. Fuse melted 	<ol style="list-style-type: none"> 1. Supply power again 2. Re-connect to power 3. Insert plug into socket 4. Replace fuse
The dehumidification effect is not significant	<ol style="list-style-type: none"> 1. Scaling in the air filtering mesh 2. Block in the air intake of dehumidifier 3. Door and window is open 4. Refrigerant leaks 	<ol style="list-style-type: none"> 1. Clean filtering mesh 2. Remove blocks 3. Close door and window 4. Contact agent or manufacturer for repairing
Water leakage	<ol style="list-style-type: none"> 1. Machine till 2. Water outlet pipe is blocked 	<ol style="list-style-type: none"> 1. Adjust machine in a level 2. Disassemble the panel and remove the dirt inside the Pipe
Abnormal noise	<ol style="list-style-type: none"> 1. Machine placing i\$ not stable 2. If the filtering mesh is blocked 	<ol style="list-style-type: none"> 1. Place the machine stably 2. Cleaning the filter trap

1. When above malfunction cannot be eliminated and require repairing, please contact supplier or agent, please do not disassemble the machine by do-it-yourself.
2. The circulating sound of refrigeration could be heard except operation or stop of the machine, this is normal but not malfunction.
3. Air outlet exhaust hot air is normal.

Warranty

Kesnos offers a 12-month warranty to all of our products, newly purchased and unused, from Kesnos or through an authorized reseller, together with the original proof of purchase when a defect occurred, wholly or substantially, or as a result of faulty manufacturing, parts or workmanship during the Warranty Period. The warranty does not apply if damage is caused by other factors, including without limitation of:

- (a) Normal wear and tear;
- (b) Abuse, mishandling, accident or failure to follow operating instructions;
- (c) Exposure to liquid or infiltration of foreign particles;
- (d) Servicing or modification of the product other than by Kesnos.

These are our general terms for the warranty service, but we always urge our customers to reach out to us with any issue, regardless of warranty terms. If you experience an issue with a Kesnos product, please contact us at support@kesnos.com, we will do our best to resolve it for you.

Extend Your Warranty by 1 Year

Register your product at www.kesnos.com to extend your 1-year warranty by an additional year.

*Please filled out all required fields and include your order ID, Date of Purchased if applicable.

Customer Support

If you have any questions or concerns about your product, please feel free to contact our expert support team. Kesnos customer service is here to help!

Kesnos Office

13211, Spring Street Baldwin Park, CA, US

Email: support@kesnos.com

Live Chat: www.kesnos.com

Support Hours

24 Hours available

*Please have your order number before contacting customer support.

KESNOS

For FAQs and more information please visit:
www.kenos.com



@Kesos



@Kesos



@Kesos



@Kesos



(Scan the QR Code for Live Chat)

We would love to see our product being used and how it makes your day!! Your support means the world, Please tag us if you share a snap on your social media.

www.kenos.com