



LIGHTFOX

PEGASUS LED DRIVING LIGHTS USER GUIDE



LF-DL9-LED6

Read and understand the warning and cautionary points and installation instructions and keep this manual close at hand for reference.

V1.0



LIGHTFOX

ABOUT US

Lightfox, founded in August, 2017, is an Aussie brand that is built around professional 4x4 lighting solutions and centers on delivering superior output with excellent value and rock-solid reliability that has won the trust of outdoor enthusiasts across Australia.

From the R&D of 4x4 LED auxiliary lights, to the optically upgraded reflectors, strictly tested wiring harness, switch, and control panel, our range of products are built to fulfill your demands for lighting, and we at Lightfox work to transfer every single luminous energy to boost your vision.

At Lightfox, we strive for quality, performance, and fair prices and at the same time, offer superior value to our amazing customers. This commitment is what drives us to continuously develop and improve our products to fulfill your needs. Because we want to make you our loyal customer.

Over the years, we've fostered a customer-oriented culture and collaborative and supportive teams that have been the key behind every progress we've made. And our passion to innovate has built Lightfox into something we're proud of.

Lightfox, The Vision To Explore Your Passion.

WARNING AND CAUTIONARY POINTS

- For your safety, read and understand this manual thoroughly before installing, operating the Lightfox LED driving lights.
- Ensure you have a good understanding of automotive mechanical and electrical procedures and systems, and that you are proficient in installing this product before installation. ALWAYS refer to the vehicle's service manuals when performing equipment installations on your vehicle.
- Remove anything that could be damaged near both sides of the surface before drilling into a vehicle. Make sure to deburr all drilled holes and smooth all sharp edges. Otherwise, it could cause serious injury or death.
- Check if there is any damage before installation. Should there be any, consult Lightfox and DO NOT use this product.
- Installation of this light should NEVER block, impair or blind the driver's vision.
- Make sure the light is installed securely and all screws are tightened securely before driving.
- Please wear protective eyeglasses and insulating gloves when installing this product. Make sure you are not wearing any metallic items such as watches, bracelets, etc.
- Make sure there are no flames or corrosive chemicals nearby during installation or operation.
- Before servicing fuses or electrical systems, disconnect any power sources connected to your vehicle.
- NEVER switch the light on and off in short intervals, otherwise its lifespan will be shortened.
- DO NOT attempt to disassemble the light as this may result in potential damage to your light and will void the warranty.
- DO NOT use the light for any purpose other than automobile use.
- When the engine is not running, turn off the light. Or it may drain the battery.
- NEVER start work before the engine compartment is adequately cool. Make sure engine parts such as radiator, oil-cooler or turbo part are cool.
- DO NOT drill holes to the main body of the light. DO NOT apply adhesives or stickers to the light parts.
- NEVER modify the harness in any way. Or it may cause the light to overheat or short circuit. It may also cause the vehicle to catch fire.
- Make sure the headlight, wipers and horn are working normally after installation.
- This LED light bar is designed to operate from 10V-30V ONLY.
- ALWAYS keep the light out of children's reach.
- NEVER use a caustic or petroleum based cleaner to clean this light bar.
- Regularly check condition of the wiring and connections.
- Before connecting electrical wires, disconnect ground connection from battery (-) to avoid accidental short circuits.
- Recommended to place rubber padding between the bracket and mounting surface to minimise vibration.



LIGHTFOX

PRODUCT DETAILS

- 1 Pair(s) Lightfox Pegasus LED Lights
- 4 Pair(s) Colour Caps (Black; Red; Yellow; Grey)
- 2 Pair(s) Clear Protective Covers
- 2 Pair(s) Blackout Protective Covers
- 1 PC(s) Wiring Harness
- 2 PC(s) Rubber Pads
- 4 PC(s) M6 Screws
- 4 PC(s) M6 Spring Washers
- 4 PC(s) M6 Washers
- 4 PC(s) M8*30 Screws
- 4 PC(s) M8*40 Screws
- 8 PC(s) M8 Spring Washers
- 8 PC(s) M8 Washers
- 8 PC(s) M8 Nuts
- 4 PC(s) M3 Screws
- 2 PC(s) M12 Screws
- 2 PC(s) M12 Spring Washers
- 2 PC(s) M12 Washers
- 2 PC(s) M12 Nuts
- 3 PC(s) Hex Keys
- 1 PC(s) User Manual



DIMENSIONS

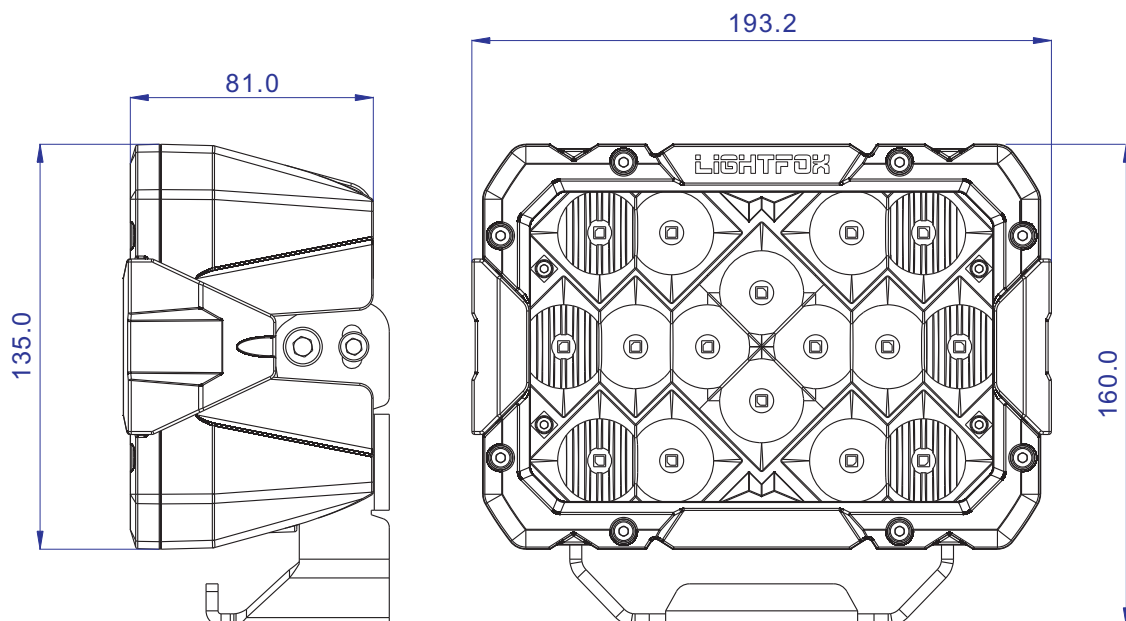

Measured in millimeter



INSTALLING BOTTOM BRACKETS AND COLOUR CAPS

Bottom Brackets: M8*30 screw > M8 spring washer > M8 washer > Lightfox Pegasus > M8 nut;
M6 screw > M6 spring washer > M6 washer > Lightfox Pegasus.

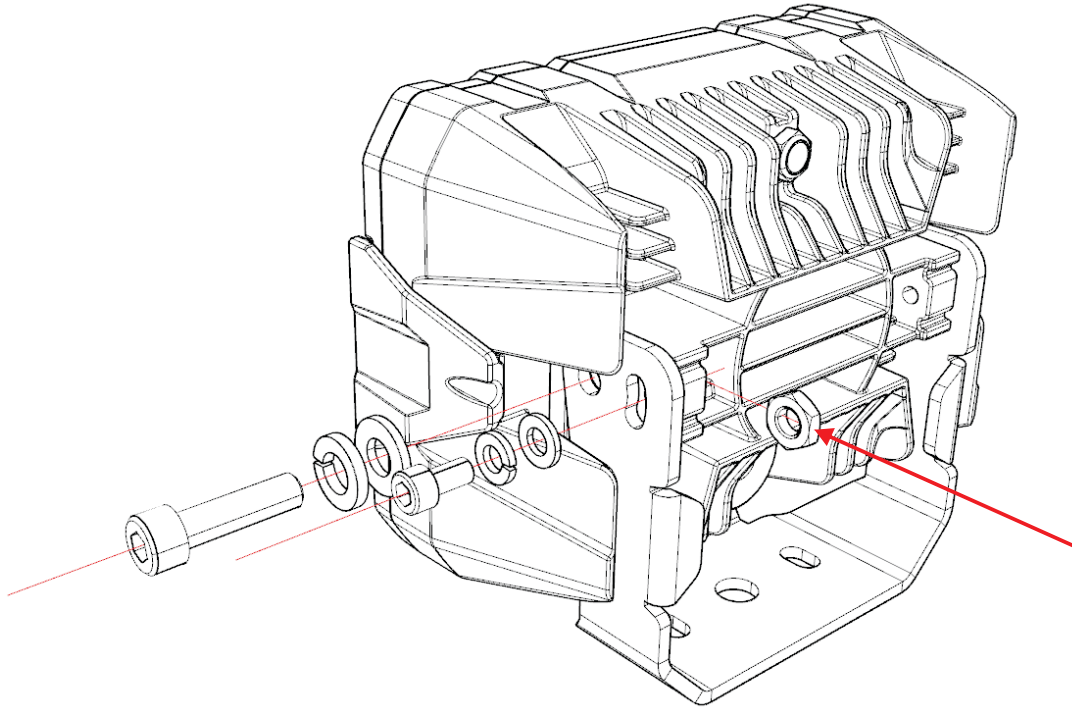

Colour Caps: The colour caps on each side of the bracket are held in by a M3 screw accessed from the rear side of the colour cap.

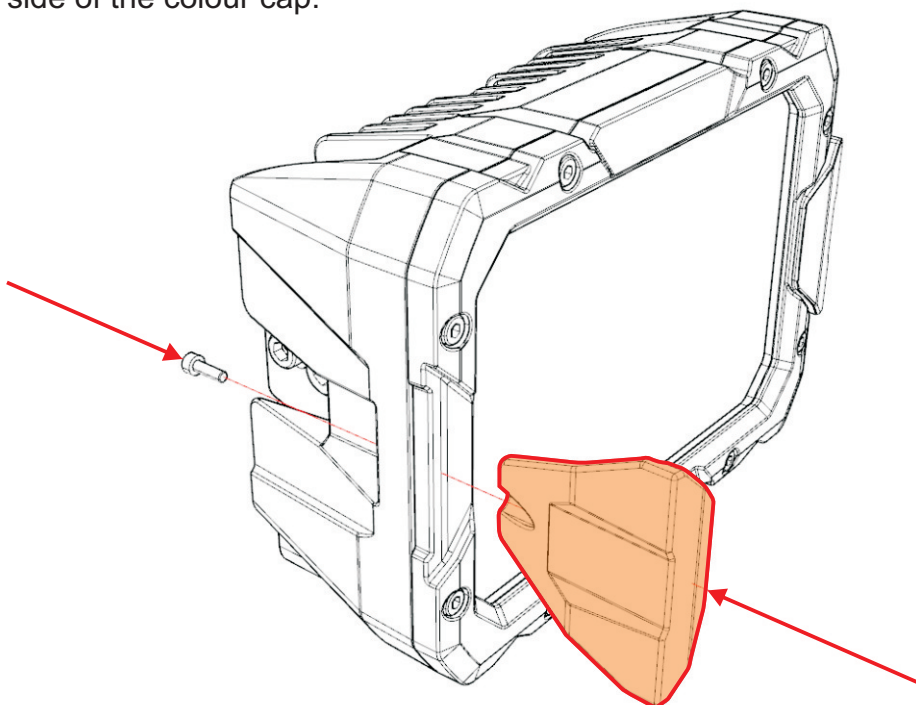



Bottom Brackets: M12 screw>Bracket>Rubber pad>Mounting platform>M12 washer>M12 spring washer>M12 nut;
M8*40 screw>Bracket>Rubber pad>Mounting platform>M8 washer>M8 spring washer>M8 nut.

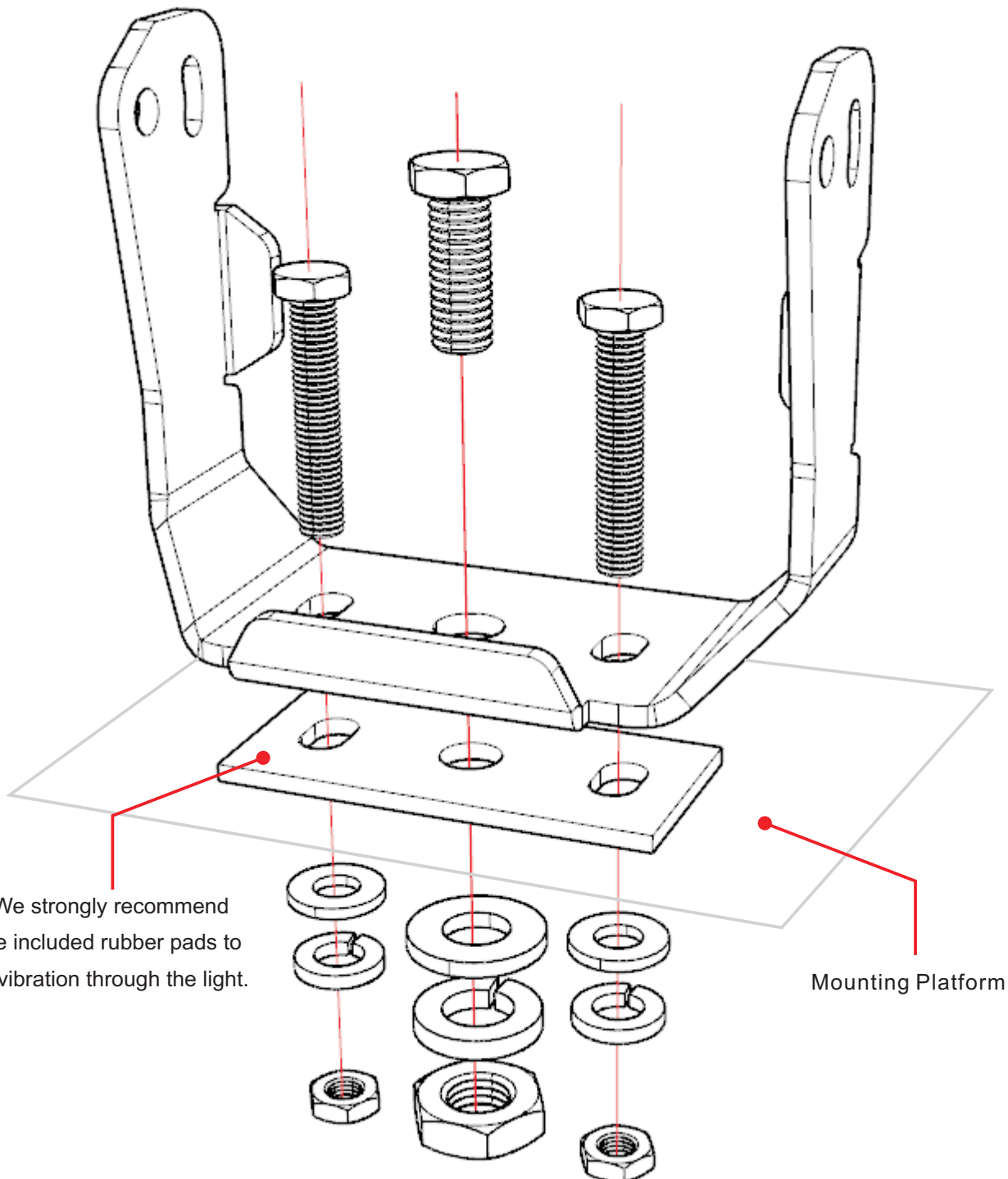

NOTE: We strongly recommend using the included rubber pads to prevent vibration through the light.

Mounting Platform

WIRING STEPS AND DIAGRAM

Step 1:

Find a suitable mounting location that will allow for running wires and mounting the Lightfox LED driving light(s). Lay out and mark where the mounting holes will be positioned. Drill appropriate -sized hole(s) for the mounting hardware. Before starting to drill hole(s), check behind locations to ensure nothing will be damaged while drilling mounting holes.

Step 2:

Mount the Lightfox LED driving light(s) with the provided hardware and with mounting brackets; be sure not to over-tighten the hardware.

Step 3:

Route the lighting side of the wiring harness from the battery to the light in a safe, secure manner. Connect the harness to the light. Be sure to avoid heat sources and any moving parts while running your wires. Typically, following the vehicle manufacturer's wiring harness is a safe path to follow.

Step 4:

Continue to route the switch portion of the harness to the desired location of the switch. The switch may need to be unplugged from the harness to make routing of the harness easier. Be sure to double-check for any obstructions and proper clearance. Drill an appropriate-sized hole for the switch. Connect the wires to the switch, and mount it.

Step 5:

Connect the black (ground) wire to the negative battery terminal. Connect the red (power) wire to the positive battery terminal.

Step 6:

Finally, aim the light in the desired direction, and tighten all mounting hardware.



LIGHTFOX

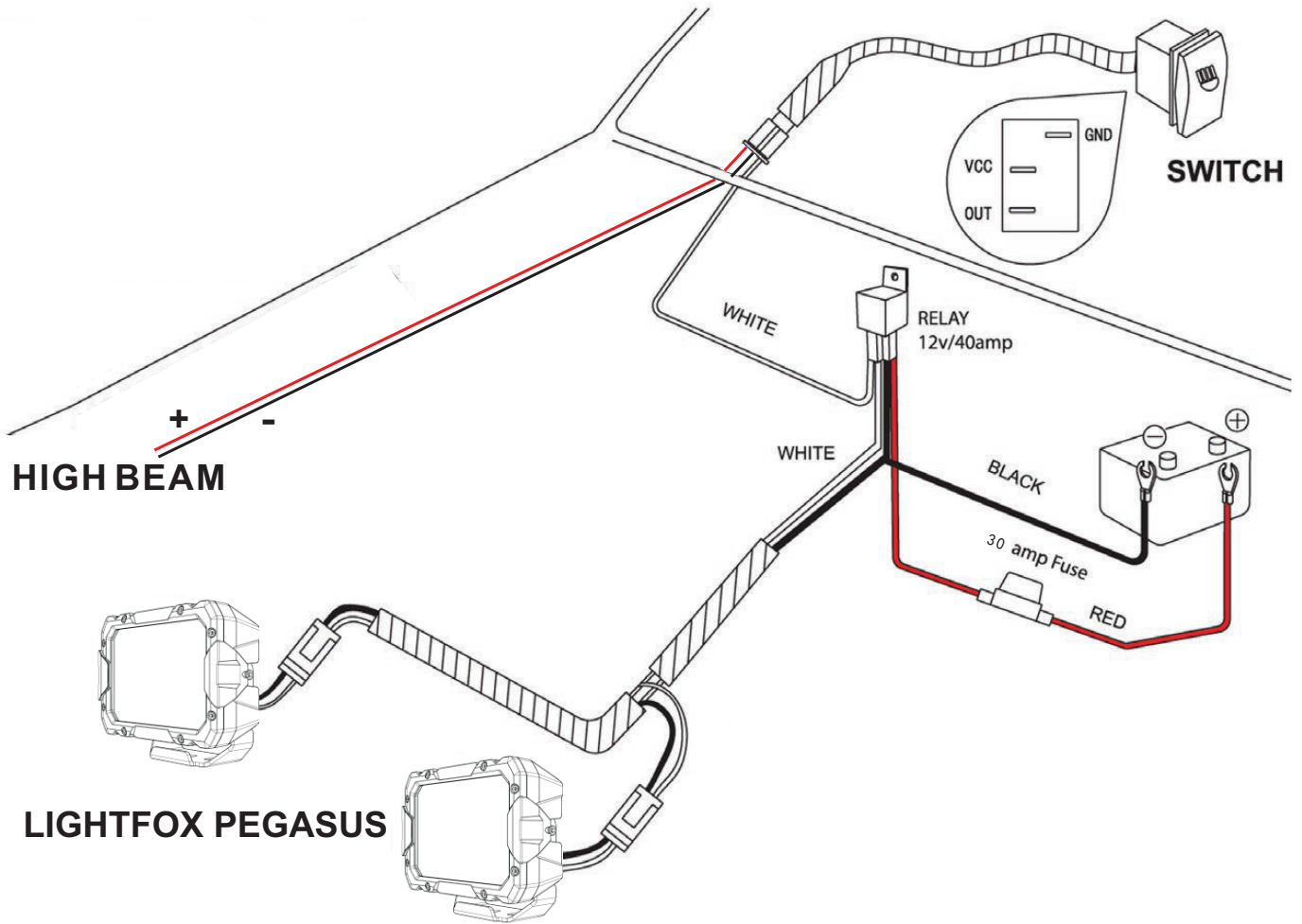

Warning! We recommend contacting your local dealership if you are unable to locate the accessory fuse slot in your car.



LIGHTFOX

WARRANTY

Lightfox ("Manufacturer") warrants to the original buyer ("User") that its Pegasus LED Driving Lights sold hereunder shall be free from material defects in workmanship or materials and conform to Lightfox's specifications for this product under normal application, installation, use and maintenance conditions from the date sold and for the duration (the "Warranty Period") of 5 YEARS.

If it fails to operate during the limited warranty period due to defects in materials or workmanship, Lightfox will, at its option, replace it with the same or similar product, or issue a refund. This limited warranty is provided by Lightfox and there are no other warranties, expressed or implied, except as required by law, including warranties of merchantability and fitness for a specific purpose, that are provided for herein, however all such implied warranties, if any, are limited to the duration of this specific limited product warranty. Oral statements or representations about the product do not constitute warranties.

THE WARRANTY DOES NOT COVER:

Defects caused by normal wear and tear, inadequate maintenance, transportation, storage or failure to observe installation or maintenance instructions set forth in the Lightfox's instructions. Damages to parts or products resulting from tampering, accident, abuse, misuse, negligence, unapproved modifications, fire or other hazards; improper operation; unauthorized repairs, submersion, theft or vehicle crash.

Damages whatsoever (including, without limitation, consequential damages, incidental damages, or damages for loss of use, loss of profits, loss of time, inconvenience, or other losses, etc) arising out of the misuse, or inability to use a Lightfox product.

CLAIMS:

No returns will be credited without an authorization. If a Lightfox product is suspected of being defective, you'll need to provide proof of purchase (e. g. a screenshot of the order) and a picture of the damaged goods in their entirety to sales@lightfox.com.au or the seller you purchased from for evaluation. Removal, installation, or reinstallation costs are not covered by this limited warranty.

