

WALLKE

Wallkebike.com 

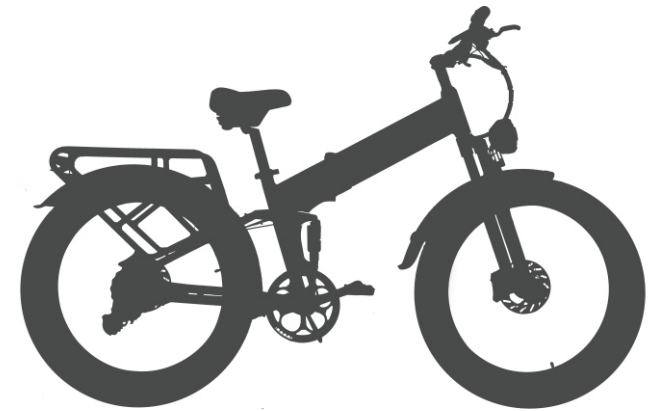

X3 PRO 2023



**OWNERS
MANUAL**





Thank You For Purchasing Wallke Ebike!

We take pride in bringing you a quality product that will offer years of enjoyment. Please read and understand this manual fully before assembling and riding your bike.

If you have questions after reading this manual, please contact us by email, or give us a call on the phone.

We Are Here To Help!

-  **Wallke Ebike Website:** www.wallkeebike.com
-  **Website Service Email:** sales@wallkeebike.com
-  **Amazon Service Email:** info@wallkeebike.com
-  **Phone:** 1-323-841-3459

Please attention that Wallke ebike have several sales channels now. Choose the right one to get connected! Email is preferred. Please send your purchase date and order ID so that we can handle your issue faster. Feel free to give us a call when needed.

Thanks For Riding Wallke Ebike!

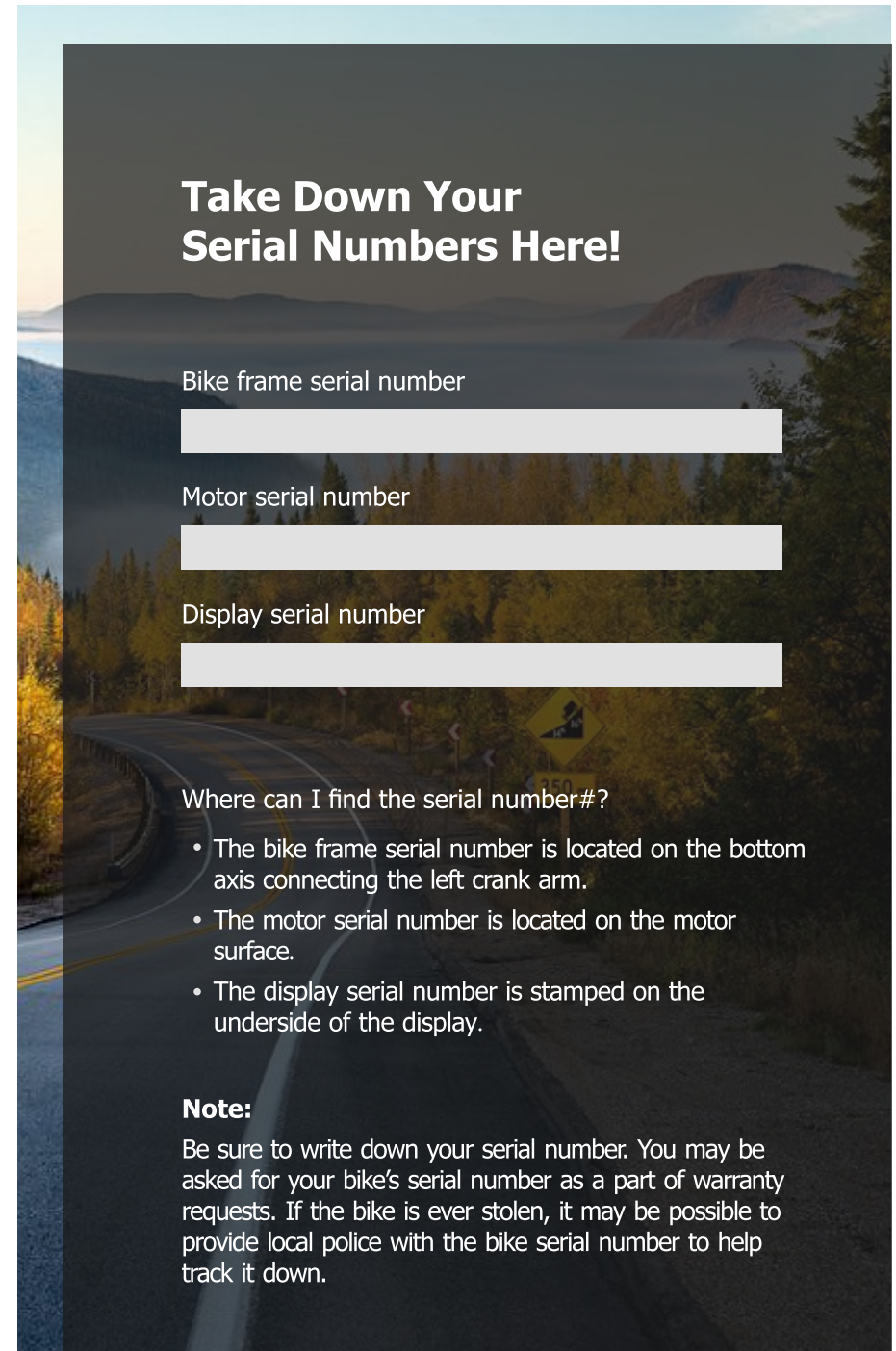

Take Down Your Serial Numbers Here!

Bike frame serial number

Motor serial number

Display serial number

Where can I find the serial number#?

- The bike frame serial number is located on the bottom axis connecting the left crank arm.
- The motor serial number is located on the motor surface.
- The display serial number is stamped on the underside of the display.

Note:

Be sure to write down your serial number. You may be asked for your bike's serial number as a part of warranty requests. If the bike is ever stolen, it may be possible to provide local police with the bike serial number to help track it down.

Where Can I Find My Ebike's Serial Number?

Every bike receives a unique code, serving as a means of identifying a single bike against those of the same model. With this number we can manage the bicycle's warranty in case of a problem, identify the exact model with its year of manufacture or, in the worst case scenario, file a complaint in case of theft, among other things.



You will likely find your serial number on the motor itself.



The display serial number can be found at the back of the display.



The bike serial number beneath the bottom bracket, aligned parallel to the frame.



IMPORTANCE

Please read this owner’s handbook carefully before using your X3 PRO in order to become thoroughly familiar with the correct operation of your bike’s controls, its features, capabilities, and limitations. This handbook includes safe riding tips, but does not contain any of the techniques and skills necessary to ride an electric bicycle safely.

This owner’s handbook includes assembly and maintenance work which may need to be done at frequent intervals to maintain an operational and safe X3 PRO. Never perform work on your X3 PRO beyond instructions in this handbook. This handbook is not intended as a comprehensive use, service, repair or maintenance handbook. Do NOT ride your X3 PRO if it has been assembled incorrectly. Maintenance beyond what the owner’s handbook instructs is to be handled by an E-Bike specialist or professional cycle mechanic. Riding an incorrectly assembled bike can put your own safety at risk as well as others.

▲ Disclaimer: Must be 18 years of age or older to ride

Note:

Do not modify, disassemble, or replace the original electrical components on your bike. Doing so will could put you in danger. Riding any type of bike comes with some risks which can’t be predicted or avoided. Taking proper care of bike components can lower the risk of sudden failure of components but cannot prevent it. These sudden failures could cause serious harm, injury, or death to the rider. If you notice abnormalities in any component on the bike, take it to a licensed mechanic to be repaired or replaced immediately. Wallke eBikes assumes no liability for harm, injury, or death of the rider.

TABLE OF CONTENTS

IMPORTANCE P5

COMPLIANCE WITH THE LAW P7

UNDERSTANDING YOUR X3 PRO P8

UNBOXING P9

ASSEMBLY P12

OPERATING YOUR NEW E-BIKE P17

ADVANCED FEATURES P20

CARE & MAINTENANCE FOR YOUR NEW E-BIKE P26

SAFETY TIPS P29

BATTERY SAFETY P30

X3 PRO SPECIFICATIONS P32

GENERAL TROUBLESHOOTING P33

ERROR CODES & TROUBLESHOOTING P34

PLEASE NOTE:

This manual is not intended as a detailed user, service, repair or maintenance manual. Please seek assistance from a qualified technician for service, repairs or maintenance.



COMPLIANCE WITH THE LAW

Read This First: Safety And Compliance With The Law

Congratulations on your purchasing of your new e-bike. Your new e-bike is an excellent piece of personal transportation equipment that will give you good service for many years.

Before you start using your e-bike, we want you to be aware of a few important points. Please read this section carefully..

● Observe Laws Regarding The Use Of Battery-Operated Bicycles

Your e-bike is designed and manufactured to meet safety requirements as a battery-operated bicycle. However, state and local laws governing the use of battery-operated bicycles on public roadways, parks, and other open areas may differ. Please check with your local authority before using your e-bike in public areas.

● Observe Laws Regarding the Use of Bicycles

Note that all laws regarding the use of bicycles in public areas, such as those mandating the use of helmets and the use of infant seats, will automatically apply for e-bikes. Check with your local authority on what restrictions might apply.

● The Lithium-ion Battery Of Your E-Bike

Your e-bike is equipped with the latest battery technology. The lithium-ion battery is much lighter than lead- or nickel-based batteries that are being used in some older models.

● Your First Ride

Please be VERY CAREFUL when you are ready to get on your e-bike for the first time because that the e-bike moves significantly faster than a regular bicycle at active power-assisted mode. Take your e-bike to an area with a lot of open space before you start. Do not start pedaling hard as soon as you get on the e-bike (as you normally would so with a regular bicycle), as the e-bike will accelerate under pedal-assist mode and you may be unprepared for the sudden increase in speed. However, after a few times, you will enjoy using the pedal-assisted function.

UNDERSTANDING YOUR X3 PRO

Your X3 PRO is a rear-hub drive, Class 3 eBike with a 750W power drive system.

It's important to understand that the bike has two completely separate (but complimentary) drive systems:

- ◆ an electric drive system that powers the bike through the controller and/or throttle
- ◆ an eight-speed system you power by pedaling yourself

Although the two systems work independently, using them together is what makes the eBike experience so versatile and enjoyable.

Important note: Because your X3 PRO is a rear-hub drive, the gear system is for pedal power only, and has no effect on how the electric power system drives the bike.

● Name Of Each Part

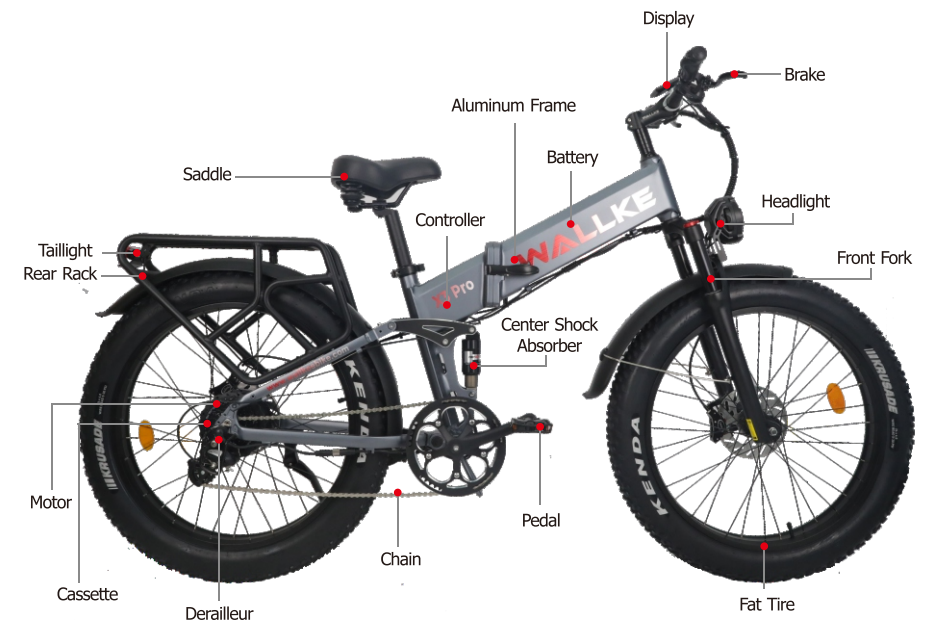



UNBOXING

● Preparation Checklist

- ◆ Headlight
- ◆ Battery Charger
- ◆ Front Fender
- ◆ Battery(Pre-installed)
- ◆ 2 x Keys For The Battery(Tie on the handlebar)
- ◆ Saddle
- ◆ User Manual
- ◆ 1 x set of Pedals
- ◆ Tool Kits

Carefully check the package contents, if any parts are missing or damaged, please contact Wallke customer service immediately for assistance with providing your order ID#: info@wallkeebike.com (Amazon/Walmart) sales@wallkeebike.com (Wallke website)

It is recommended to retain the original packaging for a short period of time and keep it as intact as possible.

For warranty and returns, you are responsible for providing a new box at your expense if you have discarded the original box in which the product was shipped. PLEASE RETAIN YOUR BIKE BOX even if it has been damaged in shipping.

▲ Riding a bicycle is an inherently dangerous activity, and it is your responsibility to ride safely and within your abilities. Proper assembly is vital to the safe operation of your bicycle, so seek professional assistance if you are unable to complete the assembly of your bicycle as outlined in this manual.

Before assembling your bike, it is recommended to remove the battery for the following reasons:

- ◆ Determine if the battery is drained or damaged during the transportation.
- ◆ Reduce the weight of the bike to make it easier to maneuver the bike when assembling. Avoid battery damage during assembly.

How To Remove The Battery?

- ◆ Rotate the hinge lock safety upwards to disengage from the fold lock lever
- ◆ Pull the fold lock lever and disengage it from the frame
- ◆ Fold the bike at least 90° so the battery can clear the rear frame
- ◆ Use the correct key to unlock the battery
- ◆ Using your key in the small slot, pry up the battery pull handle
- ◆ Use the battery pull handle to slide the battery rearward





ASSEMBLY

Please read the instructions entirely before assembly to ensure the proper functioning of the X3 PRO. Failure to do so could result in serious personal injury or damage to the bike.

Assembly Instructions

● Step 1: Handlebar(4mm&5mm Allen Screw Wrench)

1. Loosen and rotate the handlebar stem 180 degrees so that it faces toward the front of the bike. Retighten the stem's bolts to secure it to the head tube. (Do not over-tighten!)
2. Unscrew the 4 bolts and remove the handlebar clamp.
3. Center the handlebar in the stem and rotate it to the correct angle. Replace the clamp faceplate and keep the handlebar centered. Partially tighten all four bolts to hold the handlebar at the desired angle. As the clamp tightens around the handlebar, make sure the gap between the clamp and the body stem is parallel.
4. Tighten the top bolt of the stem, then retighten the stem's bolts to secure it to the head tube. (Do not over-tighten!)



Reverse the process to re-install the battery

We recommend charging the battery for 5-6 hours on the first charge. This will help condition the lithium-ion cells for optimal performance.

How To Charge The Battery?

The battery can be charged both mounted on the bike or separately from the bike. Two keys are supplied to unlock and lock the battery.

- ◆ Plug in the charger into a 120v wall outlet.
- ◆ Connect the charger cable to the battery charging port.

For your first ride, be sure to charge your battery until the light on your charger turns green, depicting a full charge.



NOTE:

Never charge the battery in a flammable environment. For safety reasons, the charger and the battery must be placed on a dry, non-flammable surface.

● Step 2: Front Wheel(15 mm Open Wrench)

1. Remove the protective bar from the front fork.
2. Pull out the red pad (if it has),which is used to protect the hydraulic brake caliper. (WARNING: Do not pull the brake lever without having either the red pad or the brake disc inserted, as this will damage the hydraulic brake caliper.)
3. Loosen the front wheel screws a little. Align the fork dropouts with the axle of the wheel hub, making sure the dropouts are fully seated on the axle. Also, ensure the brake rotor is properly inserted into the caliper.
4. Tighten the nuts with the tool. Make sure that the front wheel moves freely and does not wobble from side to side. Reposition the wheel and re-tighten if necessary.



● Step 3: Front Fender And Headlight(4mm & 5mm Allen Screw Wrench)

The headlight and front fender are both secured by a single bolt, so the front fender should be installed together with the front light.

1. Unscrew and remove the bolt using the 5mm Allen screw wrench, and reinstall the headlight with the front fender together.
2. Tighten the bolt and connect the light wire(if it disconnects). Pay attention to the arrows on the wire connectors, making sure the arrows align with each other to avoid damaging the interior circuitry.
3. Remove the nuts and washers attached to the front fork which are used to fix the front fender, put the fender iron bar in the right place, then tighten the bolts using the 4mm Allen screw wrench.



● Step 4: Pedals(15 mm Open Wrench)

1. Look for a letter marking "L" "R" on each respective pedal and make sure you install the left pedal on the left crank, the right pedal on the right crank.
2. Thread the right pedal onto the right crank gently by hand, turning clockwise. Then tighten pedal by the wrench.
3. Thread the left pedal onto the left crank gently by hand, turning counter-clockwise. Then tighten pedal by Allen wrench.
4. Check the chain alignment. Rotate the right pedal and crank toward the back of the bike as though pedaling backward. Watch the chain and ensure the chain runs through the drivetrain (the rear cog, chain tensioner, and around the front chainring) smoothly

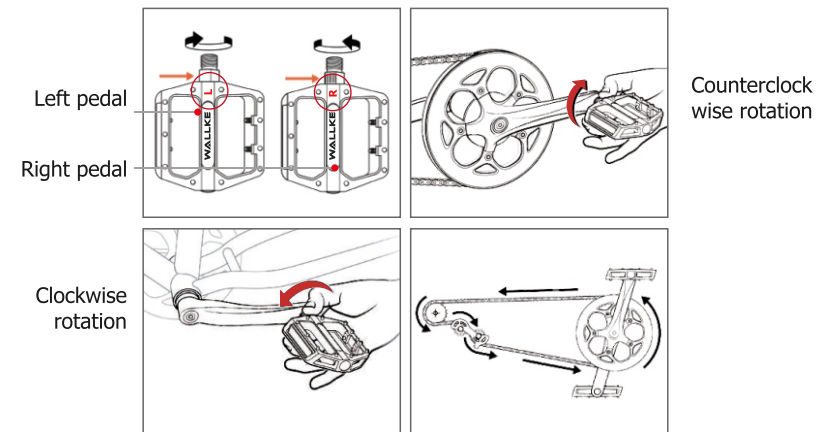

Using the Battery Keys: Unlock, Power On and OFF

Your bike comes with two identical keys to turn your battery on and off. These keys are unique to your bike. For help with lost keys, you may need to replace a new battery head.

The battery has 3 key positions: UNLOCKED, OFF, and ON. These positions are marked on the battery and can only be seen when the battery is removed from the bike.

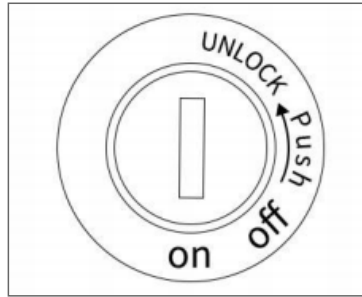

- **"Unlocked" position - remove the battery**

Turn off the bike. Press and hold the power button on the LCD Display remote (or the power button on the LED remote) until the display turns off.

Use the key to turn off and unlock the battery. Insert the key into the key port, then push and rotate the key to the "Unlocked" position. Be sure to remove the key from the battery before removing the battery from the bicycle.



- **"ON" position - The power will be active**

The power will be active, and the key will be locked into the battery so that it cannot be removed. The key must be turned to the ON position for your bicycle to function.

Note: Be careful not to drop or damage the battery when loose from the bike.

Do not touch the "+" and "-" terminal contacts on the bottom of the battery when the battery is removed from the bike.



OPERATING YOUR NEW E-BIKE

Powering Up Your eBike

To turn on the electric system and controller, press and hold the **⏻** button for 4 seconds.

To turn the system off, do the same. Press and hold the **⏻** button for 4 seconds. In addition, the system will turn itself off if the bike is still for 5 minutes. (This time can be changed in Display Settings.)

Your First Ride

You'll quickly get the feel for your bike and its electric system. For your first ride, you may want to follow these steps:

- 1) turn on the electric system and controller by holding the **⏻** button for four seconds.
- 2) If the bike is not showing mode **⓪**, press the **⊖** button until it does (the electric mode is disabled).
- 3) Start off, riding the bike with pedal power.
- 4) When you're steady and stable, press the **⊖** button to set mode **①**, enabling the electric assist.
- 5) Being ready for the bike's assist to come in, begin to pedal (after a pedal rotation or two, you will feel the assist come in).
- 6) When you're ready for the bike to move under electric power only, press the throttle slowly until the bike powers forward.
- 7) Brake to a stop when you're ready.

- ◆ The electric power system won't engage if the bike is already going faster than the mode **①** range (approximately 10 MPH /16 kph).

After your initial ride, you can experiment with higher modes, using the **⊕** and **⊖** buttons to change them.

(Remember: mode **⓪** will turn off the electric drive. Setting mode **①** or higher will turn it on again.)

Using The Pedal System

The pedal system will be familiar to nearly everyone, but there are a few practical things that can help you make the best use of it.

- ◆ You can select the best gear for your riding situation using the two buttons on the right handle bar. (The best gear is the one that balances between having to push too hard and having to pedal so fast that you can't really push very much at all.)
- ◆ The gears will only change when you're pedaling forward, so be sure to do so when you're changing gears.
- ◆ A low gear is best for starting to move again after stopping, so be sure to gear down and you're slowing for stop. This will make starting up again much easier.
- ◆ Because your bike is a rear-hub drive model, the gears in the pedal drive system have no effect on the electric drive system.
- ◆ If you want to operate your bike a pedal-only mode, select Mode **⓪**. (see Operating Modes)

Using The Electric Drive System

The electric drive system can either fully power the bike without your assistance, or can provide assistance when you're pedaling.

PEDAL-ONLY

In this mode, the X3 PRO will perform like a normal bike, as you'll be riding without any assistance from the motor. This mode is especially useful if you run out of battery, or are looking for more intensive resistance training.

What The Display Shows

Your X3 PRO has a sophisticated color digital display.

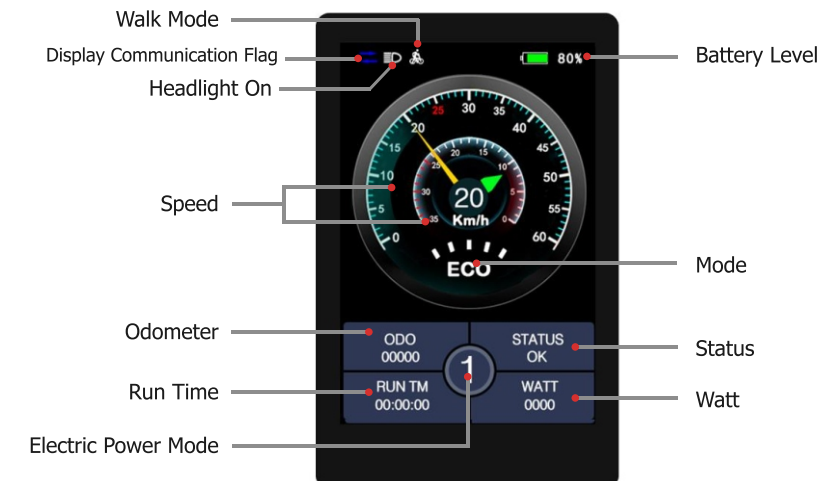

The main display shows speed, battery level, motor power, ODO, status, mode, run time, and trip information.

The two little blue arrows blinking on the top left of the screen is a communication flag. It indicates that all the electrical components are working normally.

Operating Modes

Modes ①–⑤ set the relative power (speed) level. Mode ⑩ disengages electric drive.

Electric power mode will be important when riding, as the modes determine the speed range for the bike at any particular time. Mode ① will drive the bike at a comfortably low speed, while mode ⑤ will power the bike up near the maximum available speed for electric assist.

Change the mode to the desired level when riding using the ⊕ and ⊖ buttons on the handlebar control.

System Control

The electric power system and display are controlled with the handlebar control.



The ⊕ and ⊖ buttons set the electric power mode, and are also used in the settings panels.

The ⊕ button will switch the headlight on or off. (Hold the plus button for 3 seconds until lights turn on, repeat to turn off)

Long press the ⏻ button will power up or power down the electric system. (Press for 4 seconds to turn the system on or off.)

The ⏻ button cycles through the modes in the multi-function display.

Press and hold the ⊕ button on the button pad to turn on the headlight and taillight. The battery must be inside the bike.

Press the ⊖ along and ⏻ until you see a icon on the screen, you should now have access to cruise control settings.

ADVANCED FEATURES

Cruise Control

Your X3 PRO has a cruise control capability. If enabled in Advanced Settings you can engage the cruise control by holding the bike at a constant speed for 5 seconds. When engaged, the bike will hold a steady speed until the brake is applied or the mode is changed.

For safety reasons, and because cruise control is not permitted in all jurisdictions, the feature is not enabled in the bike's default configuration. To enable the option, press the power and minus button at the same time until you see CRU icon on the screen(lower left quarter), you should now get the cruise to work.

Walking Your Bike

Sometimes it's necessary or wise to walk your bike, rather than ride it. In this type of situation, particularly where your bike needs to be walked uphill, the electric drive system can assist.

When off your bike, press and hold the ⊖ button. The drive will engage at a low speed and power your bike forward. To stop the assist, release the ⊖ button.

The speed of the assist on level ground is approximately that of a brisk walk, so be prepared to walk quickly when using the walk mode on level ground.

- ◆ **Note:** Use caution to not engage walk mode unknowingly. This mode is engaged by holding the minus button on the display control pad and will engage the motor up to a walking speed.

Using The Headlight And Tail light

The bike headlight and taillight can be operated by momentarily pressing the plus button.

For increased visibility, also ensure the front headlight and rear tail light are turned on and adjusted such that other people on the road can see them clearly.

- ◆ **Note:** The battery must be inside the bike.

USB Device Charging

Your X3 PRO has an USB charging port.

It is under the display button pad. Open the rubber cover to expose the port available to charge your phone.

Changing Display Settings

Use the ⊕ or ⊖ buttons to move the highlight up or down.

Use the power button to select the highlighted item.

Once the item is selected, use the ⊕ or ⊖ buttons to change the item's value. When the desired value is reached, press the power button to lock in the value.

Long press to return to the main display.

USER Settings

The USER settings panel contains factory setting not usually adjusted by riders. Use care and good judgement if you decide to change them.

You can go to advanced settings by:

- ◆ Press and hold both the ⊕ and ⊖ buttons.
- ◆ Press power to highlight USER SETTINGS.
- ◆ Select by pressing the power button.



USER Settings Panel

Limit Current	maximum current allowed by the controller (this protects the motor and controller – changing this value can significantly reduce the life of both)
Limit Speed	Maximum speed supported
Wheel Select	Size of drive wheel (including tire)
Voltage Select	Controls how the battery charge display interprets the voltage levels of the battery

- ◆ **Note:** Some of the USER settings configure the controller and display for the exact hardware of the bike. Changing these settings can cause the bike to malfunction, or could potentially damage certain components. Changing these settings is unlikely to improve the bike.

Current Limit

This controls the automatic protection circuit in the controller so your battery and motor are protected. Changing this from the factory setting won't improve the bike's performance, but it will disable important protections designed to prevent very costly repairs.

Speed Limit

This sets the upper limit of speed where power assist will be provided. You can set this to be consistent with local regulations.

Wheel

This sets the size of the wheel for the purpose of calculating speed from wheel rotations.

Standby Time

This sets the inactivity time after which the electric system will power down.

Gear Set

Changing your Power Set from the default 0-5 to 0-9 will give you more speed ranges to choose from when riding. As part of changing to a new power set, you can also change the percentage of total available power that drives each mode.

- ◆ **Note:** Please do not use display charging port to supply power to your high power device, which is not conducive to normal work and detrimental to the health of your eBike display. Our warranty does not include damage from power surges, use of an improper charger, improper maintenance, or other such misuses, normal wear, or water damage.

Adjusting The Front Suspension

The firmness of the front suspension can be adjusted for balance between performance and ride comfort. It also has a travel gauge so you can see the travel of the suspension after riding.

To adjust suspension firmness, turn the control knob at the top in the direction of the arrow that will increase or decrease the firmness of the ride.



Front Suspension Adjustment

- ◆ For maximum range, lockout the suspension by turning the dial all the way in the ⊕ direction.

Check that your suspension fork is properly adjusted for the terrain and your weight. The suspension fork will affect the handling of the bike, primarily when going over bumps and stopping. In some situations, it may be advantageous to lock out the suspension so it is fully rigid.

- ◆ **Note:** Intensive use of the X3 PRO may cause possible damage to the frame and the fork. It is important to inspect the frame and the fork and look for signs of cracks. A broken or cracked frame and fork can cause an accident and injury.

Note:

The brand of parts advertised on our website may vary depending on the ongoing supply chain constraints in the eBike market. Component changes may occur without prior notification. All parts have been carefully inspected to ensure they equal the performance standard of the products advertised.

Display Settings

The display settings panel displays and can set the most common parameters you may need to change.

You can go to display settings by:

- ◆ Press and hold both the ⊕ and ⊖ buttons.
- ◆ With MENU highlighted.
- ◆ Press the power button to select.

StandBy Time	Number of minutes of non-use before the bike system turns itself off
Mileage Zero	Used to reset the TRIP odometer
Gear Set	Number of modes available (default 0-5)
Mileage Unit	Set metric or imperial units
Digit Meter	Switch the display interfaces
Back Light	Control how the display responds to low-light environments



Display Settings Panel

Mileage Zero/TRIP Reset

Change this value to YES to reset the trip odometer. This also clears the MAX and AVG speeds.

Set Voltage

Sets the behavior of the battery monitor as it translates battery voltage into the battery charge and percentage indicator on the display. Changing this from the factory settings will usually make the battery charge display less accurate.

Power Set

To provide a larger number of defined speed / power ranges, you may choose to take advantage of the controller's programmability to create a more versatile Power Set.

To do so, change the Power Set to 0-9. After you select MENU with the power button, a small menu will appear where you set the power levels. Enter the following power levels, using plus/minus button to change each value, and then the power button to lock in the value.

These setting will deliver a wider range of speeds, including a lower speed for mode ① .

Changing the speed

To change the speed of the bike:

1. Access the settings menu by pressing and holding the plus and minus buttons on the control pad simultaneously until the screen shows the settings panel.
2. Please go to setting "USER" and hit the power button on the control pad.
3. Change speed limit setting as your requirements.
4. Hold the power button to save the settings you have just changed.
5. Exit the display setting page and restart the display.

Eco Mode & Sport Mode

Level 1-3

Eco mode (Lower power)

Level 4-5

Sport mode (Higher power)

Walk Mode: Push assistance mode

CARE & MAINTENANCE FOR YOUR NEW E-BIKE

You should in general, take care of your e-bike the way you would with a regular bicycle by keeping it dry, clean and the moving parts well lubricated. You should also avoid parking your e-bike in exposed areas whenever possible.

You should check the effectiveness of the brakes before each use.

● For Your E-Bike, You Should Also Take Note Of The Following:

- ◆ Your e-bike is designed for regular country road use for a single person. Using your e-bike for extreme maneuvers, such as extreme off-road use, jumping, or carrying the excessive load will damage the e-bike and could cause serious injury.
- ◆ Do not use high-pressure water streams to clean your e-bike, as water might seep inside the motor or the wiring compartment and cause rusting of electrical parts or short circuits.
- ◆ Avoid parking your e-bike outside when there is rain or snow. At the end of a trip where there was rain or snow, bring the e-bike inside and use a clean, dry towel to eliminate any wetness.

● Battery Maintenance

- ◆ Use only the supplied charger to charge your battery. Do not use an unauthorized substitute. If your charger is lost or damaged, contact us to order a replacement.
- ◆ Do not open or alter the battery or the battery charger.
- ◆ Do not place the battery near fire or corrosive substances. Do not immerse in water or other liquids.
- ◆ Avoid subjecting the battery from high temperatures, such as directly under the hot sun, for prolonged periods of time.
- ◆ Do not connect (short circuit) the two poles of the battery.
- ◆ After much use, your battery's charge holding capacity will decrease. If you find that your battery does not hold sufficient charge even for short trips, you should contact us to order a replacement. Under normal use, the battery will undergo 1000 charging and discharging cycles.
- ◆ If the battery will not be used for an extended period of time, charge it fully and recharge it every 3 months. Store it in a cool place.
- ◆ Your e-bike battery is engineered with precision for high capacity and long useful life. We do not recommend that you use it to power other electrical devices. Improper use of the battery will damage the battery and shorten its useful life and may cause a fire or an explosion.

● Motor Maintenance

- ◆ Please check your motor frequently and tighten any loose screws or nuts, to prevent the vehicle from breaking down due to disconnected wires.
- ◆ The brushless motors are not waterproof, so avoid riding through water deeper than the lower edge of the electric wheel hub to avoid motor failure.

● Brake Maintenance

- ◆ Simply check the alignment of the pads with the disc, and check that the wheel is fully pushed back. Good alignment ensures the absence of noise and a normal wear of the pads.
- ◆ Regularly check the condition of your cables, ducts or harness and the wear of your pads.

Derailleur Maintenance

If shifting operation becomes less smooth. Clean the front derailleur and lubricate the link sections shown in the illustration. If gear shifting operations cannot be carried out smoothly. Clean the derailleur and lubricate all moving parts. If the amount of looseness in the links are so great, you should replace a derailleur.

Transmission System Maintenance

The most effective way is to add lubricant. We should remind everyone that the chain should always be kept oily and sensitive, especially after wading and raining. The active parts of the front and rear derailleur must also be frequently filled with oil. The oil used for the chain and the derailleur should preferably be a rust-proof lubricant designed for bicycles. Ordinary engine oil can also be used, but the effect will be poor. If the chain is rusty, you can first wipe the rust spots with a kitchen cleaner, then clean the chain, and then wash it in diesel to restore the mountain bike chain as before.

Lubricity

When you feel the chain is a bit stuck. In order to give you a better riding experience, lubricate the chain such that there's little noise. Keep the chain at work so that it can be smooth and unimpeded to ensure the operation of the bike. Intervals between maintenance depend on the use and riding circumstances.

Handlebar

Before riding, please make sure that the handlebar is correctly installed in accordance with the video installation steps. Regularly check whether the handlebar firmware is stable. If there is any looseness, temporarily stop riding and install the installation steps to check and reinstall.

Always check the condition of your bike before you ride in addition to having regular maintenance performed. If you are unsure of how to conduct a complete check of the condition of your bike before every ride, you should consult a certified, reputable bike mechanic for assistance.

● Before And After Each Ride

- ◆ Check the alignment of the wheels.
- ◆ Check the state of charge of the battery.
- ◆ Check that brakes function properly.
- ◆ Check tires for any punctures.
- ◆ Store the bike carefully in a clean and dry place.
- ◆ Check that your kickstand is tightly secured.
- ◆ Check for loose cables or wires that may be strained when turning the front wheel from left to right.

● For The Battery, You Should Also Take Note Of The Following:

Every 1 to 2 months, it is recommended that you check the following:

- ◆ Check that the handlebar and saddle post are correctly inserted and tightened.
- ◆ Check that the wheel hub mounting nuts are correctly tightened.
- ◆ Check that the wheel rims are not cracked and that no spokes are loose or broken.
- ◆ Check that the tires are not worn or cut.
- ◆ Check that the tires are correctly inflated.
- ◆ Check that the battery contacts on the frame are not dirty or oxidized.
- ◆ Check that the batteries are sufficiently charged.
- ◆ Check that the front and rear brakes are working correctly.
- ◆ Check that the cables are sufficiently greased, and that the brake pads are in good condition.
- ◆ Check that the frame welds are in good condition, and are free of corrosion or oxidation.

● Quarterly (Or About Every 750-1500 Miles)

- ◆ Check all items on the Monthly service list above.
- ◆ Check tire tread for excessive wear. Replace if necessary.
- ◆ Check that electrical connectors and cable housings are secured away from moving parts and are free from damage. Replace if necessary.
- ◆ Go into your local bike shop for a tune-up by a certified and reputable bike mechanic.

SAFETY TIPS

We Recommend The Following Safety-related Procedures:

- ◆ Wear a helmet.
- ◆ Ride in control at all times.
- ◆ Use lights and reflective gear in low light situations.
- ◆ Inspect your bike often — especially the brakes.
- ◆ Seek maintenance if there are any notable changes in bike performance.
- ◆ Know and observe the rules of the road before cycling. Bike users must follow all road rules.
- ◆ Ride defensively. To motorists, pedestrians, or even other cyclists, you are not as visible as you might think. Always watch for hazardous situations, and be ready to stop or take evasive action at all times. With the assistance of the electric motor, you may be travelling faster than drivers expect—beware of cars pulling out in front of you.
- ◆ Avoid road hazards. Watch for and avoid potholes, drain grates, railroad tracks, loose road material, and other hazards.
- ◆ Use both the front and the rear brakes together for best performance. Using ONLY the rear will significantly increase your stopping distance.

E-Bike Road Safety

Always obey traffic laws including lights, signals, and road signs that apply to traditional cyclists, cars, and other vehicles. Stay in the appropriate lane, using bike lanes when available. Cyclists tend to break the speed limit and red light laws.

This will only put you at risk of an accident. And this is a higher risk than for cyclists because your e-bike can travel faster than traditional bicycles. Do not cycle on the sidewalk/pavements as it can put both you and pedestrians at risk;

Be wary of everyone. E-Bike company AXcess states (source) that cars will not always realize how fast you are going and may assume that you are exponentially slower than them. To avoid the risk of accidents, always allow cars to get their right of way first, and do not rush. Be patient and alert, especially at intersections and turns.

Guide To Cycling At Night

Use Lights Properly: Riding bicycle at night require lights on both the front and rear of the bike.

For extra protection, wear a clip-on bike helmet light, or purchase a helmet with built-in LED lights. Light vests are easy-to-wear over clothing to allow drivers to see the cyclist from a greater distance and ensure that the vehicle will pass with enough clearance. Turn on any built-in lights setting out to ride.

BATTERY SAFETY

These safety precautions are provided for your benefit to protect you and those around you. Please read and follow them carefully to avoid unnecessary injury, damage to the product, or damage to other property.

Battery

CAUTION

■ Do not throw the battery into a fire. Do not overheat the battery.



■ Do not connect the battery to other appliances other than your battery.



■ Use only the specified charger to charge the battery.



■ Do not take apart or modify the battery.



Disassembly Prohibited

■ Do not connect positive and negative terminals by using metallic objects.



(Electrolyte leakage, overheating and/or rupture may result in this type of abuse.)

Battery Charger

CAUTION

■ Do not take apart or modify the charger



Disassembly Prohibited

■ Do not subject the charger to shocks, e.g. by dropping. Keep the charger away from water



■ Do not touch the charger with your skin for long periods during charging

■ Buring of the skin may result, as external temperature of the charger during charging may become 40C-60C(104F-140F)



Overheating, fire or electric shock may result

■ Do not cover the charger or place objects on it

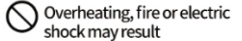

■ Place the charger firmly on a flat dry surface

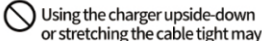

■ Do not short-circuit the terminals by using metallic objects



○ Overheating, fire or electric shock may result



○ Using the charger upside-down or stretching the cable tight may result in malfunction, fire or electric shock



○ Overheating, fire or electric shock may result



⚠ WARNING

- Keep the battery away from water. Pouring water on the battery may result in short-circuit, overheating or permanent damage of the battery.
- Do not submerge the battery. Soaking the battery in water may cause irreparable damage.

⚠ WARNING

- Do not apply pressure to the cable or the plug.
- ⊘ Placing the cable tightened between a wall and a window frame, or placing heavy objects on the cord or the plug may result in electric shock or fire.
- Be sure to insert the plug securely into a wall socket.
- ⊘ Electric shock and overheating may result, causing fire.
- Do not touch the plug with wet hands.
- ⊘ Electric shock may result.
- Keep out of reach of children or pets.
- ⊘ Electric shock or injury may result.
- Do not attempt to use another maker or model's charger to charge the battery.
- ⊘ Overheating, fire or electric shock may result.
- Do not use the charging plug and/or the power source Plug when they are dirty, wet or dusty.
- ⊘ Insulation failure due to moisture absorbed in the dust may result, causing fire.
- Pull out the power source plug and clean it with a dry cloth.
- To remove a cable from a socket, pull the plug, not the cable.
- ⊘ Always pull the charging cable gently.
- Do not rotate the pedals when charging the battery while it is mounted on the bicycle.
- ⊘ The cord may twist around the pedal or the crank, and the damage to the plug may result, causing electric shock or fire.
- Do not apply voltage over the rated value to the charger.
- ⊘ Do not use sockets, correctors and other wiring devices with a power source other than standard rated voltage (AC110-240 volts) power supply.
 - Overheating, fire or electric shock may result.
- Do not use damaged components such as charge case, power cord, plug etc.
- ⊘ Electric short, short-circuit or fire may result.

Do not store the bike for more than 24 hours with an empty battery. This prevents a deep discharge with irreparable consequences from occurring.

Charge the battery and use the bike at least once every 90 days.

X3 PRO SPECIFICATIONS

Our bikes have a number of different traits, so it might not be possible to get every single attribute you want in the same model. Please find the specifications of our X3 PRO as listed below.

Battery	48V 20AH lithium battery
Motor	48V 750W brushless motor
Maximum payload weight limit	300 lbs
Charging time	5-6 hours
Charger	US standard 48V 3A smart charger
Battery Charger Input Volt	110/220 volt AC
Battery Operational Temperature	0° to 40° Celsius (32° to 104° Fahrenheit)
Battery Life	Approximately 1000 complete charge/discharge cycles
Frame	26 inch aluminum alloy foldable frame
Display	Full-color LCD display (with USB port)
Freewheel	Shimano 8 speed cassette
Fork	26-inch alloy hydraulic shock absorption, adjustable and locked suspension fork
Brake	Double-disc hydraulic brake
Transmission	Shimano 8 speed
Seat	Silicone seat
Tire	26 x 4.0 inch fat tires for mountain, snow, rain or muddy road
Pedal Sensor	Cadence Sensor
Fender	Included
Rear Rack	Included
Front LED Light	Included
Taillight	Included

The brand of parts advertised on our website may vary depending on the ongoing supply chain constraints in the eBike market. Component changes may occur without prior notification. All parts have been carefully inspected to ensure they equal the performance standard of the products advertised.

GENERAL TROUBLESHOOTING

As one or more causes of failure might lead to the failure phenomenon, you should find out the true cause(s) and then take the appropriate solution(s) to rectify the problem. In case of doubt, please consult a qualified technician for service, repairs or maintenance.

Phenomena	Possible Causes	Solutions
It doesn't work	<ol style="list-style-type: none"> 1. Insufficient battery power 2. Faulty connections 3. Battery not fully seated in tray 4. Brakes are applied 5. The bike will report a error code 	<ol style="list-style-type: none"> 1. Charge the battery 2. Clean and repair display connectors 3. Install battery correctly 4. Disengage brakes
Irregular acceleration and/or reduced top speed	<ol style="list-style-type: none"> 1. Insufficient battery power 2. Loose or damaged throttle 	<ol style="list-style-type: none"> 1. Charge or replace battery 2. Replace throttle
When powered on, the motor does not respond	<ol style="list-style-type: none"> 1. Loose wiring 2. Loose or damaged throttle 3. Loose or damaged motor plug wire 4. Damaged motor 5. The bike will report a error code 	<ol style="list-style-type: none"> 1. Repair or reconnect 2. Tighten or replace 3. Secure or replace 4. Repair or replace
Reduced range	<ol style="list-style-type: none"> 1. Low tire pressure 2. Low or faulty battery 3. Driving with too many hills, headwind, braking and/or excessive load 4. Battery discharged for long period of time without regular charges (aged or damaged) 5.Brakes rubbing 	<ol style="list-style-type: none"> 1. Adjust tire pressure 2. Check connections or charge battery 3. Assist with pedals or adjust route 4. Replace the battery 5. Adjust the brakes
The battery wont charge	<ol style="list-style-type: none"> 1. Charger not well connected 2. Charger damaged 3. Battery damaged 4. Wiring damaged 	<ol style="list-style-type: none"> 1. Adjust the connections 2. Repair or replace 3. Battery Voltage Testing
Wheel or motor makes strange noises	<ol style="list-style-type: none"> 1.Damaged motor bearings 2. Damaged wheel spokes or rim 3. Damaged motor wiring 4. Disc not centered 	<ol style="list-style-type: none"> 1. Replace 2. Repair or replace 3. Repair or replace motor 4. Adjust the brake or replacea
Sensor Issue	<ol style="list-style-type: none"> 1. Sensor loose 2. Sensor or cable broken damaged 	<ol style="list-style-type: none"> 1. Adjust the connections 2. Repair or Replace
Pre-load and turn off bike suddenly	<ol style="list-style-type: none"> 1. Battery or motor over heat protection 2. Battery or controller cable loose 3. Battery or controller cable damaged 	<ol style="list-style-type: none"> 1. wait 1-3 minutes to restart e-bike 2. Adjust the connections 3. Repair or Replace

ERROR CODES & TROUBLESHOOTING

In the event of a problem with the electrical components of your bike, the display will show an error code.

Compare the code with this list below and HOW TO RESOLVE:

CODE	ERROR	HOW TO RESOLVE
24	Overcurrent Error	Check the cable that connects the rear hub motor to the rest of the system. Make sure it is free from grit or contaminants and is firmly connected.
102	Throttle Error	When you press and release the throttle, it should return to the original position. Remove any obstructions. Check the throttle and throttle cable for damage, such as a cut or frayed cable.
34, 35	Motor Phase Error	Check the cable that connects the rear hub motor to the rest of the system and make sure it is free from grit or contaminants and is firmly connected. This error might appear if you don't reconnect the cable after removing the rear wheel (for example, after changing a flat tire, or transporting your bike in the trunk of a car). At least one of the motor phase wires has been damaged or is temporarily disconnected.
36	Motor Hall Sensor Error	The hall sensor inside the rear hub might be disconnected or damaged. Service or replace the rear hub.
101	Brake Error	When you apply the brakes - built in "magnetic reed switches" disengage the motor's power when the lever is squeezed. If the lever is damaged (for example, following a crash), it might need to be replaced.
26	Over voltage	Poor connection between the controller and the display, check all cable connections.

Wallke E-Bike Warranty

Every Wallke E-bike is covered under our manufacturer's one year all-inclusive warranty for the original owner against all manufacturing defects.

Note: The warranty applies only to original owners and is not transferable.

What About Warranty On Wallke?

Parts covered by the warranty: frame, forks, stem, handlebars, headset, seat post, saddle, brakes (excluding brake pads), lights, bottom bracket, crank set, pedals, rims, wheel hub, freewheel, cassette, derailleur, shifter, motor, throttle, controller, wiring harness, LCD display (excluding damage due to water), kickstand, reflectors, and hardware. The battery warranty does not include damage from power surges, use an improper charger, improper maintenance or other such misuse, normal wear, or water damage.

The warranty does not cover an incorrect assembly or installation of the product by the user; an improper or negligent use, operation or transformation of the product; a maintenance contrary to the maintenance instructions of the product (eg. lack of maintenance of the brakes); normal wear and tear; defects inherent to the normal useful life or service life of the product, such as a flat battery that can be replaced by the consumer; damages or defects due to accidents.

Notes:

Failure caused by the following cases are not included in the warranty contents. However, the designated store or sales dealer has the responsibility and obligation to provide paid repair service:

- ◆ Without invoice and the warranty.
- ◆ Using and maintaining without complying with the user's manual.
- ◆ Using the electrical bicycle for other purposes or dangerous acts.
- ◆ Dismantling the parts without permission or improper use and storage.
- ◆ Without using the original parts.
- ◆ Traffic accidents or other accidents.
- ◆ Anti-rust layer damage caused by abnormal use, which leads to the corrosion and fracture of the parts.
- ◆ Riding on the abnormal road conditions.
- ◆ Commercial rental use.
- ◆ Irresistible natural disasters.

Shipping Damage Claims

IMMEDIATELY inspect your product(s) for damage. Shipping damage must be reported to Wallke Ebikes within 7 days of shipment arrival. We will not accept Shipping Damage Claims later than 7 days from receipt of products.

What Will We Do To Correct Problems With Your Bike?

If any component is deemed to be defective or damaged without user error, we will issue a replacement part and assist you in replacing the defective parts. We will replace any parts deemed to have been damaged during shipping.

Contact Us

If your question has to do with your order, please include your order number and eBike serial numbers.

eBike serial numbers: Each bike has a serial number stamped on the bottom axis connecting the left crank arm.

Order ID: You can find this in the order history of the account the purchase was made through.

Please contact our service department at the below email. Please attach any relevant videos or photos showing your issue so the specialists can best assist you.

Please attention that Wallke electric bike has several sales channels now. Each sales channel has its order list and covers its own after service, including the warranty service, return service, and all.

Choose the right one to get connected! Or could not get the answers! If you've already submitted an inquiry, be assured that we are working diligently to respond (within 24 hours).

 **Wallke Ebike Website:** www.wallkeebike.com

 **Website Service Email:** sales@wallkeebike.com

 **Amazon Service Email:** info@wallkeebike.com

 **Phone:** 1-323-841-3459

- ◆ **Note:** If for some reason you didn't receive our reply email within 48 hours, please kindly check your spam folder.