



NRO-03000.1

User Manual



CLASS-D MONO BLOCK POWER AMPLIFIER

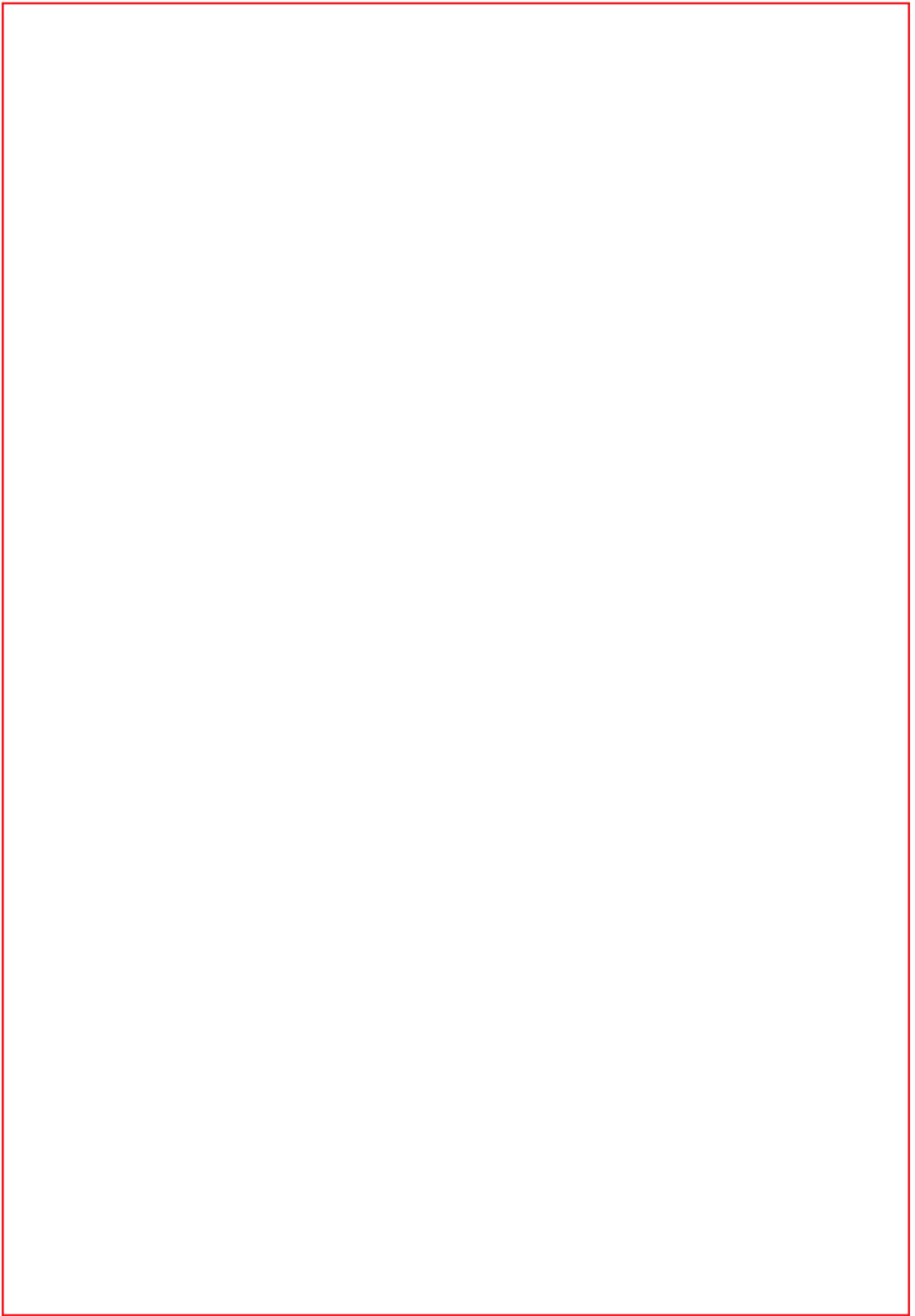

INTRODUCTION

Thank you for your purchase of our Nakamichi product and we warmly welcome you to the Nakamichi family ! Do keep your original invoice and purchase receipt in a safe place in case of future service and warranty claims . You may also contact your appointed Nakamichi service agent for any future technical support requirements.

ACCESSORY LIST

1. User Manual	2pcs
2. Amplifier	1pc
3. Mounting Screw (Ø3 x10mm)	2pcs
4. Mounting Screw (Ø4 x20mm)	4pcs
5. Gasket	4pcs
6. High input line	1pc
7. Wired remote control	1pc
8. Fuse	1pc
9. Wrench (2mm and 4mm)	2pcs

SPECIFICATIONS

N-power Output @ 1Ω (T.H.D. 10%)	3000W x 1
N-power Output @ 2Ω (T.H.D. 1%)	1600W x 1
N-power Output @ 4Ω (T.H.D. 1%)	1000W x 1
Max Power	18000W
Frequency Response	10Hz - 20kHz
Input Sensitivity	200mV to 5V
Signal To Noise Ratio	≥90dB
T.H.D.	≤0.2%
Low Pass Cross Frequency	80Hz - 20kHz
High Pass Cross Frequency	10Hz - 80Hz
Bass Boost	0dB - 10dB
Minimum Impedance	20KΩ
Fuse Size	200A X 1
Net Weight	Approx. 2.6 kg
Dimensions (L x H x W)	235x190x54mm

All specifications subject to change without notice.

DIMENSIONS

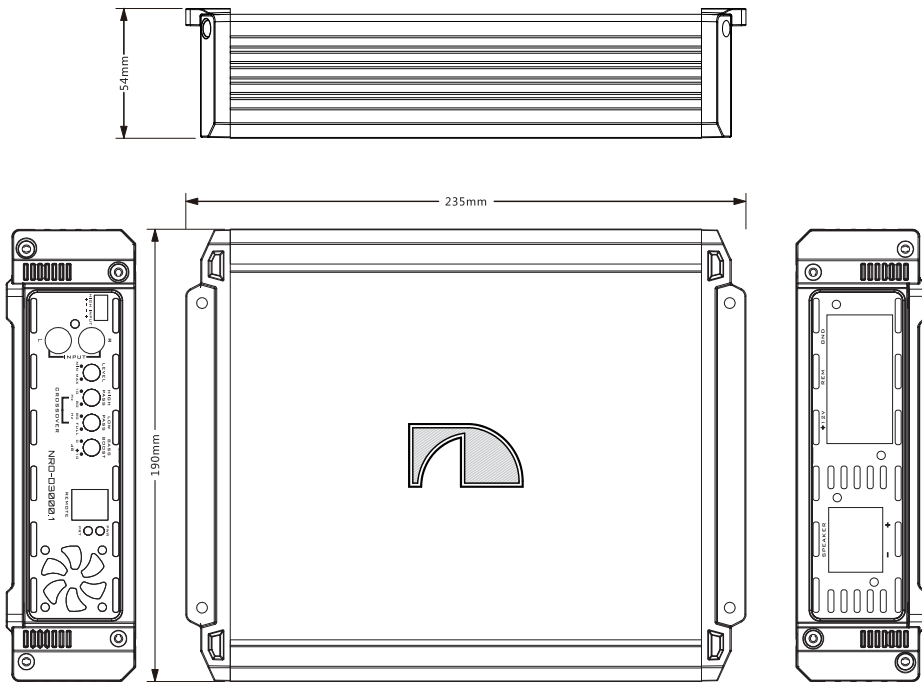

PANEL CONTROLS AND FEATURES

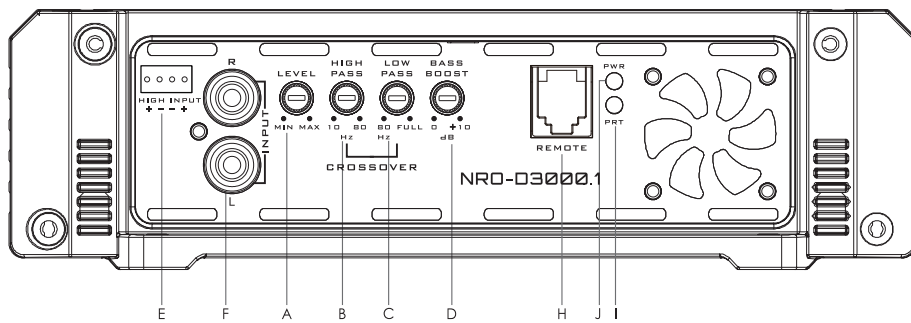

PANEL CONTROLS AND FEATURES

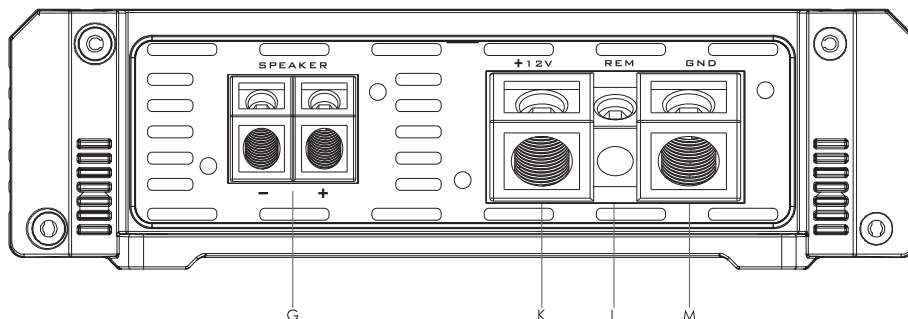

A. LEVEL CONTROL

The gain control will match the amplifiers sensitivity to the source units signal voltage.

B. HIGH PASS CROSS FREQUENCY

This control can filtered out unwanted low frequency from 10Hz to 80Hz.This function will increase the power handling of your woofers.

C. LOW PASS CROSS FREQUENCY

Controls the frequency of the power amplifier of Low frequency reduction to common denominat or is 80Hz to 20KHz.

D. BASS BOOST CONTROL

The Bass BOOST feature will increase the sound level in the bass frequencies at 0-6-12dB.

E. HIGH LEVEL INPUT

Only when your audio source unit does not use low-level input , Has a high level of output.

F. LOW LEVEL RCA INPUT

These RCA input jacks connect with your source unit RCA Low level outputs or via optional adapter with your source unit speaker high level outputs. The use of high quality twisted pair car audio cables is recommended to mind possibility of disturbance the audio signal.

G. SPEAKER CONNECTIONS

connect speakers/subwoofers to these terminals. Be sure to check wire for proper polarity. Never connect the speaker cables to chassis ground.

H. REMOTE

Attach the included remote level control to control the volume level of the amplifier independently.

I. Protection indicator

this red LED will light up and will be flashing if there is a fault presented to the amplifier. Please disconnect the amplifier and resolve the fault before reconnecting the amplifier.

J. Power indicator

this LED will light up when amplifier works properly.

K. + 12V = POWER SUPPLY

connect this terminal through a fuse or circuit breaker to the positive terminal of the vehicle battery or the positive terminal of an isolated audio system battery.

L. REM(ON/OFF) REMOTE CONTROL

when use Hi-Input, the amp can detect the DC offset from the high level input signal to auto turn ON/OFF. when the amp turns on , The REM terminal will output +12V DC to control the other device turn ON/OFF.

REM IN: When use Low level input , the amp rem in should be connected to the rem out of the source unit. The head unit controls the amp turn ON/OFF.

M. GND(-) = GROUND CONNECTION

Connect this cable directly to the frame of the vehicle. make sure the metal frame has been stripped of all paint down to the bare metal. Use the shortest distance possible. It is always a good idea to replace the vehicle battery ground terminal or any other factory ground points.

WIRING DIAGRAM

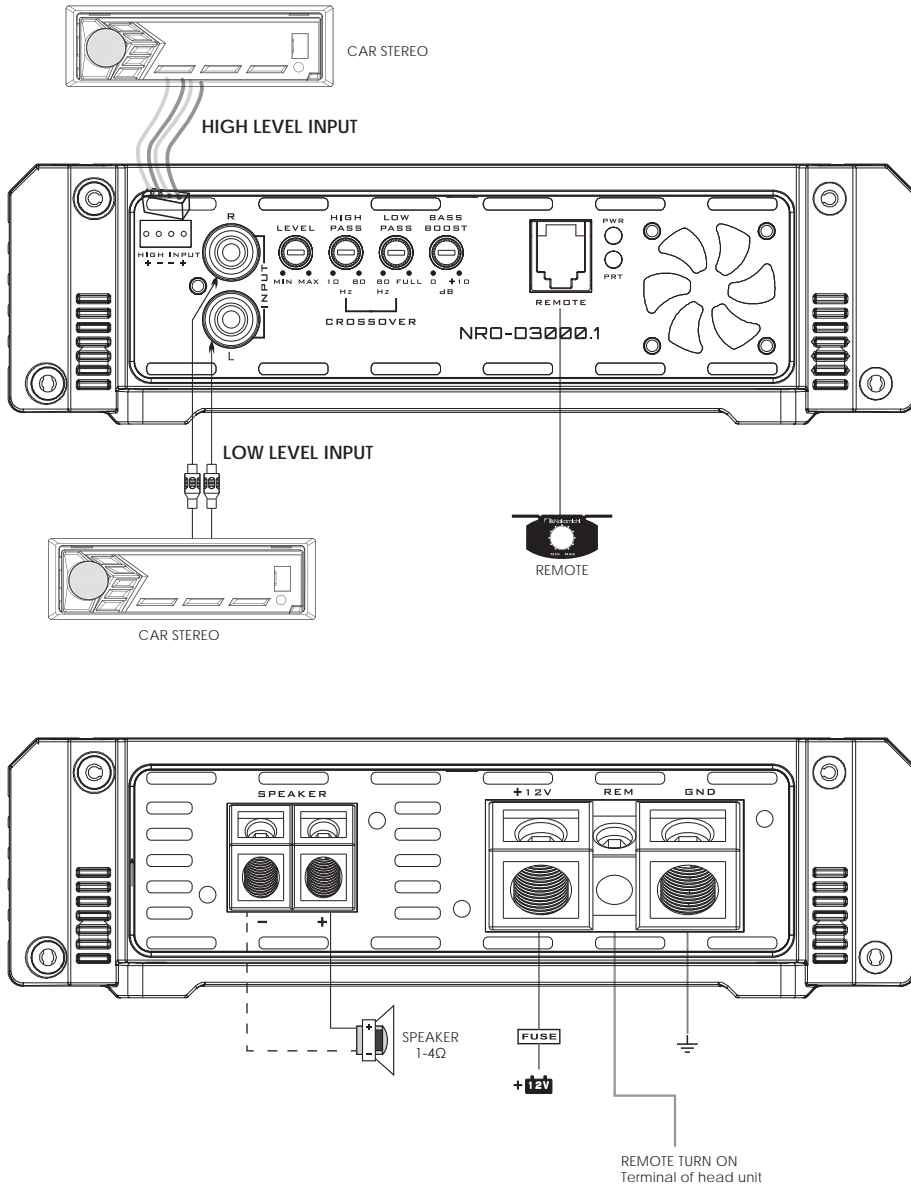

Caveat:
When signal input is connected, high-level input and low-level input cannot be connected at the same time, only one of the two can be selected.

PRECAUTIONS

- This unit is designed for negative ground 12 Volts DC operation only.
- Use speakers with an impedance of 1 Ω or 4 Ω
- Avoid installing the unit where:
 - It would be subject to high temperatures, such as from direct sunlight or hot air from the heater.
 - It would be exposed to rain or moisture.
 - It would be subject to dust or dirt.
- If your car is parked in direct sunlight and there is a considerable rise in temperature inside the car, allow the unit to cool off before operation.
- When installing the unit horizontally, be sure not to cover the heatsink fins with the floor carpet.
- If this unit is placed too close to the car radio, an interference may occur. In this case, separate the amplifier from the car radio.
- This power amplifier employs a protection circuit to protect the transistors and speakers if the amplifier malfunctions.
- Do not attempt to test the protection circuits by covering the heatsink or connecting improper loads.
- Do not use the unit with a weak auto battery as its optimum performance depends on a normal battery supply voltage.
- For safety reasons, keep the volume of your car audio system moderate so that you can still hear normal traffic sounds outside your car.

PROTECTION CIRCUIT:

This amplifier is provided with a protection circuit which operates in the following cases when:

- the unit is overheated.
- the speaker terminals are short circuited.

WIRING INSTRUCTIONS

POWER CONNECTION

The battery terminal (BATT) must be connected directly to the positive terminal of the vehicle battery to provide an adequate voltage source and minimize noise. Connecting the battery terminal lead to any other point (such as the fuse block) will reduce the power output and may cause noise and distortion. Use only #2 gauge or thicker (smaller gauge#) wire for this lead and connect it to the terminal of the battery after all other wiring is completed.

GROUND CONNECTION

The ground terminal (GND) connection is also critical to the correct operation of the amplifier. Use a wire of the same gauge as the power connection (#2 or thicker) and connect it between the ground terminal(GND) of the amplifier and a metal part of the vehicle close to the mounting location. This wire should be as short as possible and any paint or rust at the grounding point should be scraped away to provide a clean metal surface to which the end of the ground wire can be screwed or bolted.

SPEAKER CONNECTIONS

Depending on the type and number of speakers used with the amplifier wire them to the speaker terminals as per the appropriate wiring diagram. For most applications # 8 gauge wire should be used for the speaker leads but in no case thinner than # 16 gauge. For leads is excess of 10 feet # 8 gauge is recommended. When wiring the speakers, pay careful attention to the polarity of the terminals on the speakers and make certain they correspond to the polarity of the corresponding terminals on the amplifier. Do not ground any speaker leads to the chassis of the vehicle.

POWER CONNECTION LEADS

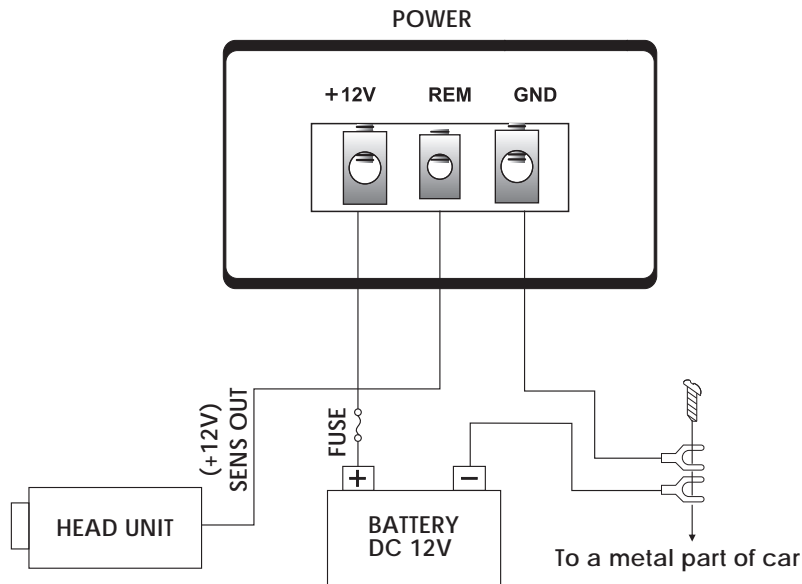

NOTES ON THE POWER SUPPLY:

- Connect the +12V power input lead only after all other leads have been connected.
- Be sure to connect the ground wire of the unit securely to a metal part of the car.
- A loose connection may cause a malfunction of the amplifier.
- REM: The unit is turned on by applying +12 Volts to this terminal. This terminal does not draw heavy current like the tow Power Terminals so a thinner connecting wire is acceptable. Standard 18 GAUGE is fine and the standard color is yellow. If the radio is equipped with a Power Antenna control wire, it can drive this terminal. If the Power Antenna wire is already in use, you can still splice into it. With this method, the unit will turn on automatically with the radio.
- Use the power supply lead with a fuse attached whose value is the same as original fuse.
- Place the fuse in the power supply lead as close as possible to the car battery.
- During a full power operation, Maximum current will run through the system. Therefore make sure that the leads to be connected to the +12V and GND terminals of the unit respectively must be larger than 4-Gauge (AWG.4).

OPERATION

LEVEL = INPUT LEVEL CONTROL

- The input level control allows the system to work well within a wide range of output level. Choose the adjustment in the way that you achieve a sound most possibly without any distortion. As a guideline the following procedure is recommended:

- If you use several amplifiers, the adjustment has to be made for each set separately. Tune in the volume of your car radio to 2/3 of the maximum volume. Now turn the gain control of the amplifier from "Min" to "Max" direction until you can hear distortions. Then turn the gain a little back until the noise disappear. The gain control adjustment is finished now.

CROSSOVER CONTROL

Low pass: the lower frequency under setting point can be pass.

BASS BOOST CONTROLS

This amplifier has Bass controls for making good sound combination.

HOW TO PROCEED IN CASE OF FAULTS

No Function:

- The connection cable is not connected correctly (=terminal +12V/GND/REM). Ensure that all connections and mechanic contact and that the jacket has been removed. The fuse is defective-pay attention to the correct value of a new fuse!

No Sound :

- Speaker cable or speaker plug are not connected correctly.

No Sound / Red LED Protection is on:

- The plus and minus wires of the speaker cable have contact, thus eliminate the short circuit. If you use a 2Ω speaker in stereo mode, a 4Ω speaker in bridge mode or tri-mode and the set is overloaded, then turn the gain control to "min" until the operation is free of trouble.

Poor Sound Quality (Distortions) :

- The speakers are overloaded, therefore turn down the volume level and check the volume control positions.

No Stereo Sound And A Weak Bass :

- Speaker cables (+) and (-) are mixed up, unit wired out of phase.

INTERFERENCE

All cables can source and create interference. The power cable and Cinch/RCA audio cable are very prone to interference; the remote cables are less prone. There is often interference caused by the generator (piping), ignition (cracking) or other car electronic parts. Most of these problems can be eliminated by correct and careful cabling. In doing so, here are the following guidelines:

- Use only a screened audio cable for the wiring between "low level in" of the amplifier and RCA or DIN output of the radio.
- Lay the signal, speaker and power cables separately with enough distance from one another and also from each other car cable. If not possible, you can lay the circuit and ground cable together with the serial cables. Audio and speaker cable should be as far away from these as possible. The REM cable to the automatic antenna output of the radio can be laid together with the signal cables.
- Avoid ground loops by laying the ground wiring of all components to a center point in a starlike way. You can find the best central point in measuring the voltage directly at the battery. Now compare this voltage value with the chosen ground point and the(+) terminal of the amplifier. If measured voltage is only slightly different, you've found the correct central. Otherwise you have to look for another point. You should measure with the ignition point for earth being switched on and additionally switched on consumers (rear window heating and light).
- If there are pickups from external electrical sources into the speaker cables, divide the core leads and twist them together.
- If there are noises from the car electrics, add an interference suppression choke into the power wiring.
- If there are humming noises, use thicker ground cables or add further ground cables to the chassis.
- To reduce contact resistance and bad and loose contacts, please solder the cable ends or use multi core cable ends, spade terminals or others. Gold Plated spade terminal are free of corrosion and have the lowest contact resistance.
- Should all these measures be without any success, the use of a ground loop isolator may solve the problem.



SCAN OUR QR CODE OR VISIT WWW.NAKAMICHICARAUDIO.COM
FOR COMPLETE AUDIO SETTINGS INSTRUCTIONS

 [nakamichi.global](https://www.facebook.com/nakamichi.global)  [nakamichi.caraudio](https://www.instagram.com/nakamichi.caraudio)

Made in China | 中國製造