

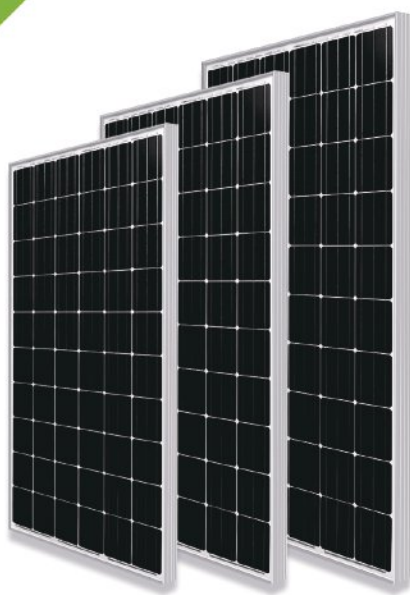

**ECO-WORTHY**  
— Reliable Solar Expert —



**ECO-WORTHY**

**Solar Panel**

PRODUCT INSTRUCTION MANUAL





## DIRECTORY

1. Disclaimer.....	1
2. Products Description.....	1
2.1 Products Identification .....	1
3. Safety Precautions .....	1
4. Placement and Positioning .....	2
4.1 Placement of modules .....	2
4.2 Positioning.....	2
5. Electrical Characteristics.....	2
6. Installation Instructions.....	3
6.1 Installation Precautions.....	2
6.2 Mounting Hole Schematic.....	4
6.3 Mounting Method.....	4
7. System Installation Guide .....	5
7.1 System Wiring Example.....	6
8. Inspection and Maintenance .....	14
8.1 Troubleshooting .....	14
8.2 Testing The Solar Panel .....	14
8.3 Cleaning and Maintenance .....	16

## 1.Disclaimer

ECO-WORTHY is not responsible for any form of damage, including but not limited to module operation and system installation error, and personnel injury, hurt, and property loss resulted from failure to follow the instructions in this Manual.

ECO-WORTHY reserves the right to change this User Manual without prior notice. Failure to follow the instructions outlined in this Manual during the installation of the module may result in a voided warranty.

Note: The data and images in the manual are for reference only, and it depends on the actual situation.

## 2.Products Description

ECO-WORTHY solar panels feature durable, high-efficiency solar cells, corrosion-resistant EVA and Transparent tempered module glass, which will protect the solar panel from various forms of damage and ensure to offer a long-lasting and stable power output.

### 2.1 Products Identification

Nameplate: Describe the product model, rated power, rated current, open circuit voltage, and short circuit current. The above parameters are obtained under standard test conditions. Standard test conditions: Irradiation intensity 1000W/M<sup>2</sup>, spectrum AM 1.5, component temperature 25°C Others. such as weight, maximum system voltage, cable length, etc. are also marked on the nameplate.

## 3.Safety Precautions



(1) During the installation, and maintenance, it is recommended that the installation be carried out by qualified personnel, and the safety equipment and safety procedures should be in place.

- (2) Do not install modules that are bent, disassembled, having module glass shattered or back-sheet damaged.
- (3) Keep the modules away from naked flame or ignition source.
- (4) Secure the modules from falling.
- (5) The output wire should be fully covered in insulation jacket. Do not touch the bare wire.
- (6) Do not install or handle modules when they are wet or during periods of high wind.

## 4.Placement and Positioning

### 4.1 Placement of modules

The modules should be placed in a well-ventilated location where there is no chance of being shaded or immersed in water. The recommended ambient temperature for solar panel is  $10^{\circ}\text{C} \sim 50^{\circ}\text{C}$ , with humidity range from 0 to 90%. Make sure the potential wind and snow load does not pass the maximum load tolerance of the modules, which are 2400Pa and 5400Pa respectively.

### 4.2 Positioning

The solar array generate maximum amount of energy output when the angle of the sun is perpendicular to the solar array. Since the actual optimal angle of positioning the solar array varies due to the earth's rotation and revolution, it is advised that to tilt the solar array up for 30-45 degree from the earth, which is a well-balanced solution when using without a solar tracker. Regarding the facing of the solar array, a general rule is that to face towards south if the panel is in northern hemisphere and vice versa. At last, a clearance of at least 115mm(4.5in) should be provided between the panel frame and the object or wall behind.

## 5.Electrical Characteristics

The voltage system of the solar panel is divided into 12V and 24V, and solar panels of the same specification can be connected in series or in parallel. The electrical performance parameters of the modules such as  $I_{sc}$ ,  $V_{oc}$  and  $P_{max}$  are nominally  $\pm 3\%$  error under standard test conditions.

When the modules are connected in series, the final voltage is the sum of the individual modules, when the modules are connected in parallel, the final current is the sum of the individual modules.

Reference map:

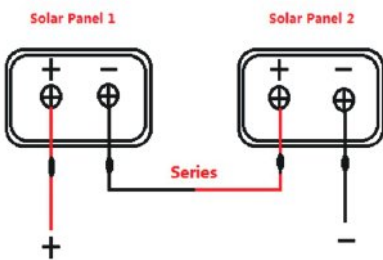

Figure 5.1 Connecting in series

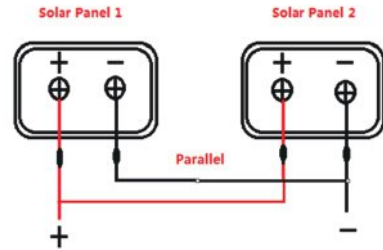

Figure 5.2 Connecting in parallel

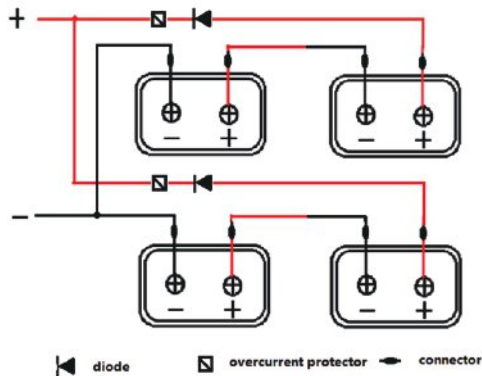

Figure 5.3 Connecting in parallel after connected in series

## 6. Installation Instructions

### 6.1 Installation Precautions

\*Cover all modules in the PV array with an opaque cloth or material

before making or breaking electrical connections.

- \* Keep the solar panel dry and clean during installation to avoid the risk of electric shock. It is recommended to install it immediately after unpacking.
- \* Always wear dry insulation protection equipment: insulated tools, head gear, insulated gloves, safety belt and safety shoes (with rubber soles).
- \* Keep the modules packed in the carton until installation.
- \* Do not drop objects on, stand of step on solar modules.
- \* Do NOT damage the back sheet of modules when fastening the modules to a support with bolts.
- \* All installations must be preformed in compliance with all applicable regional and local codes.

## 6.2 Mounting Hole Schematic

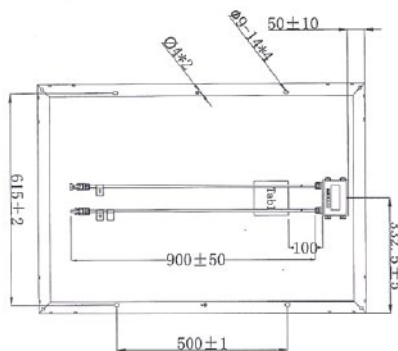

Figure 6.1 Taking a 100W polycrystalline solar panel as an example

## 6.3 Mounting Method

The connection of the module to the racking system can be created through the mounting holes or with clamps. Choose the appropriate installation method according to the conditions.

### 1) Mounting with Bolts

Secure the panel frame to the bracket with bolts through the mounting holes on the back.

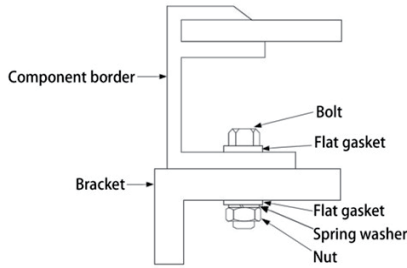

Figure 6.2

## 2) Mounting with Clamps

When choosing this type of clamp-mounting method, use at least four clamps on each module.

The clamp must overlap the module frame by at least 7mm (0.28in) but no more than 10mm (0.39in).

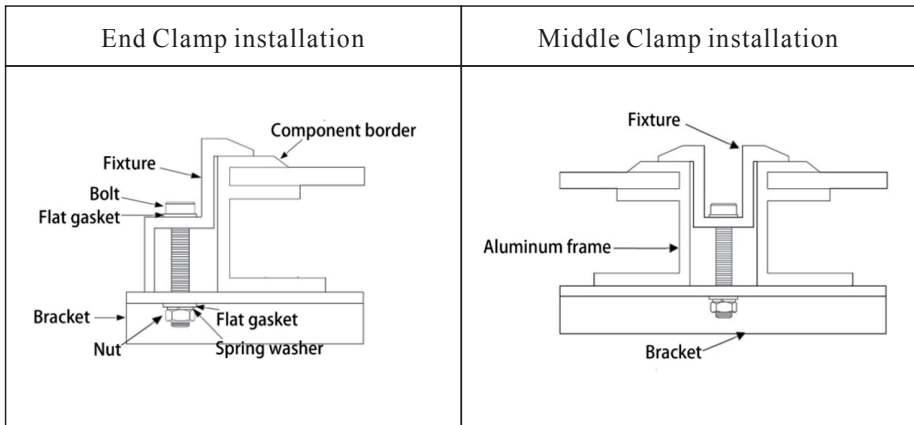

Figure 6.3

Figure 6.4

## 7. System Installation Guide

All installation methods herein are only for reference and the system is not including the mounting components. Besides, the system installer should respect the installation procedures.



Note that the positive pole is connected to the positive pole and the negative pole is connected to the negative pole.

**\*12V&24V**

System Voltage: Normally we define solar system voltage based on battery voltage.

For example: If the system is for the 12VDC battery, we call it a 12V solar system; If the system is for the 24VDC battery, we call it a 24V solar system.

ECO-WORTHY solar panel system is made up by the solar panels of the power rate above 100W.

The solar panels can be connected in series or in parallel to get the suitable voltage for the battery.

**\*Wiring**

ECO-WORTHY recommends that all wiring be double insulated. All wiring should use flexible copper (Cu) conductors.

It is recommended that you prepare the following devices by yourself before installing solar panels.

CONTROLLER	BATTERY	INVERTER	ACABLE	LOAD	BRANCH CONNECTOR
------------	---------	----------	--------	------	------------------

**7.1 System Wiring Example**

(1)An example of the 12V solar system of 1 pc solar panel:

Step 1:

The battery ports of controller is connected to the battery. Note that the positive pole is connected to the positive pole and the negative pole is connected to the negative pole. The configuration of the battery needs to be based on the power of the solar panel.

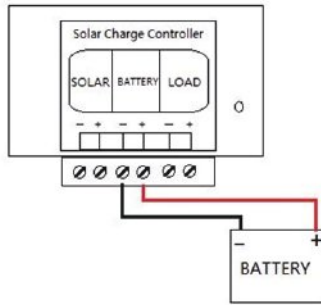

Figure 7.1.1

Step 2:

The panel ports of controller is connected to the solar panel. Note that the positive pole is connected to the positive pole and the negative pole is connected to the negative pole. When the solar panel is normally powered, the indicator light on the controller will be bright.

PS: The operating current of the controller should be higher than the output current of the solar system.

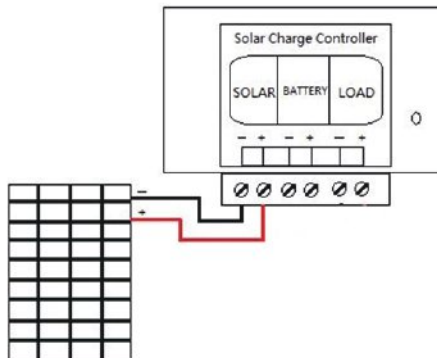

Figure 7.1.2

Step 3:

The load ports of the controller is connected to the DC load.

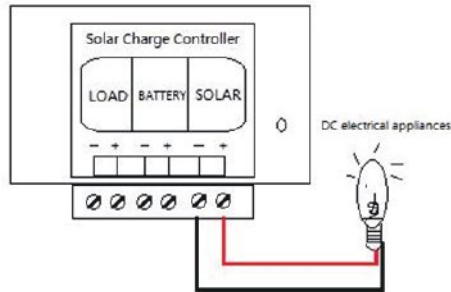

Figure 7.1.3

**Step 4:**

The input port of the inverter is connected to the battery. Note that the positive pole is connected to the positive pole and the negative pole is connected to the negative pole.

The power of the inverter should be higher than the power of the load. The operating frequency should be the same as the operating frequency of the load. In a solar panel system, the power of the inverter should be 2-3 times higher than that of the capacitive load.

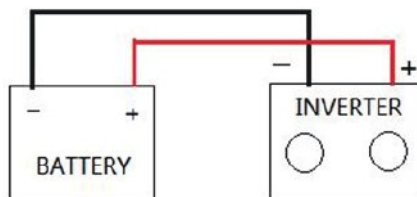
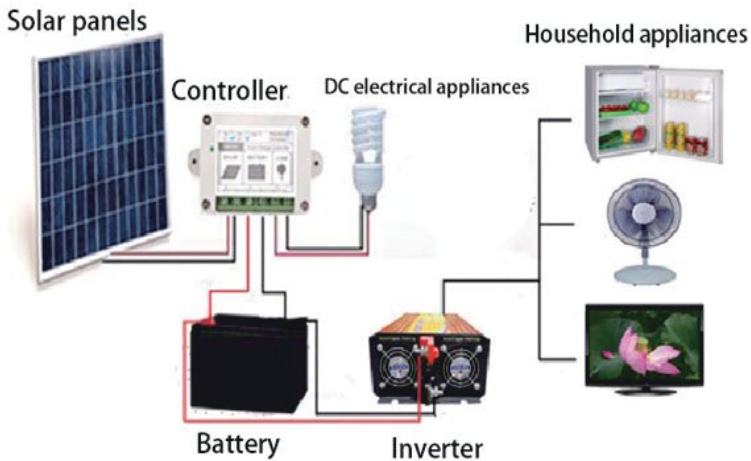

Figure 7.1.4

The wiring reference diagram of the off-grid system is as follows.



Schematic diagram of single solar panel wiring. Figure 7.1.5

(2)An example of the 12V solar system of 4pcs solar panels:

**Step 1:** Prepare 4 pieces solar panel. Figure 7.2.1



Figure 7.2.1

**Step 2:** Prepare batteries and connect 2x12V batteries in parallel. Figure 7.2.2.

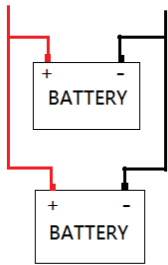

Figure 7.2.2 12V in parallel

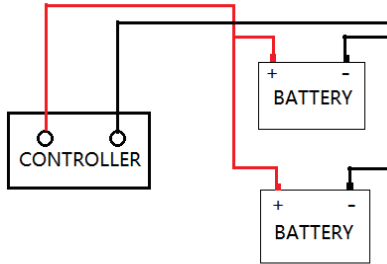

Figure 7.2.3

Step 3: Connect the battery to controllers. Figure 7.2.3

Step 4: Connect all 4 pcs solar panels in parallel. Figure 7.2.4

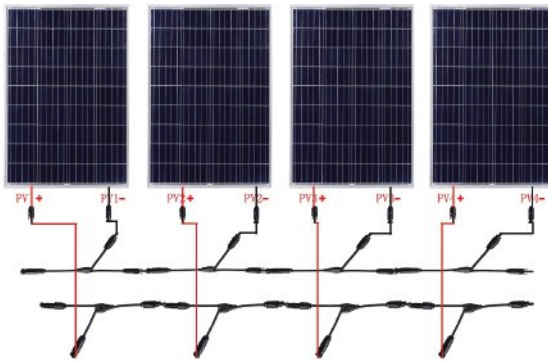

Figure 7.2.4

Step 5: Connect the extension cable to the solar panel connectors.

Step 6: Connect the extension cable to the Controller (terminal marked as solar).

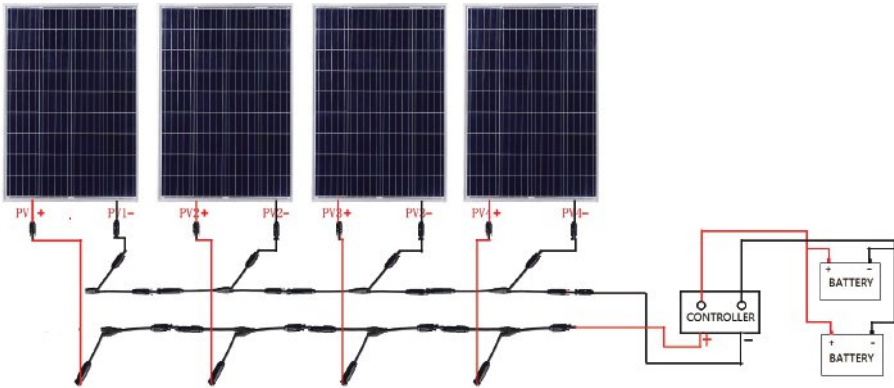

Figure 7.2.5

Now all the solar panels and controller is wired, for the load and inverter wiring Will show you later.

(3) An example of the 2 of 4 pcs solar panels: 4V solar system

**Step 1:** Prepare 4 pieces solar panel.

**Step 2:** Prepare batteries.

**Step 3:** Connect the 24V battery to the controller. Here shows the connection of 2x 12V battery in series.

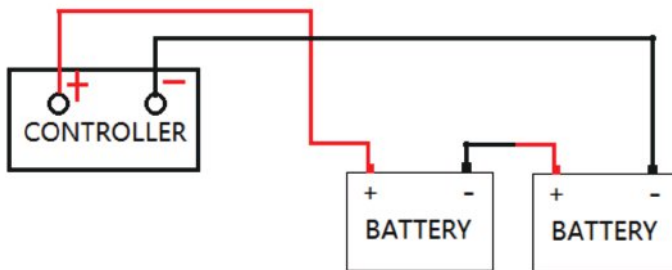

Figure 7.3.1 12V battery in series to 24V

**Step 4:** Connect all 4 pcs solar panels. Please note this wiring diagram carefully. First, connect every 2 pcs panels in parallel to get 2 strings, then connect these two strings solar panel in series.

If you have 6 pieces, 8 pieces or 10 pieces solar panels, please connect half quantity of solar panels in parallel to get 2 strings, then connect these two strings in series.

For example, if there are 8 panels in total, please connect 4 pcs in parallel to get 2 strings, then connect these two strings in series. Finally, a 24V solar panel system is made up. Figure 7.3.2

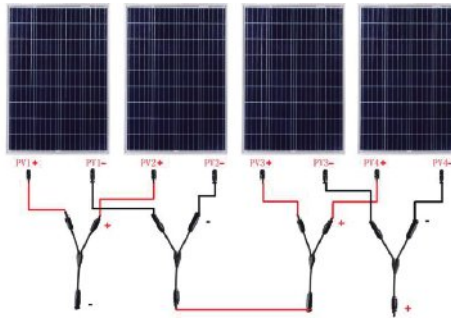

Figure 7.3.2

**Step 5:** Connect the extension cable to the solar panel connectors.

**Step 6:** Connect the extension cable to the Controller (terminal marked as solar). Figure 7.3.3

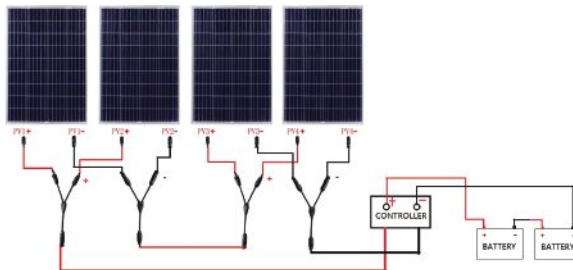

Figure 7.3.3

Now all the solar panels and controller is wired, for the load and inverter wiring Will show you later.

(4)Off-grid system System Wiring (to DC load or AC inverter)

\*Please check all above material is prepared . Follow the sequence below to set up

solar system:

- 1.Connect the off grid inverter to the battery (Polarity '+' to "+", '-' to "-")
- 2 .Connect the DC appliance to the load port of the controller if you want to power your DC appliance.
- 3 .Connect the off grid inverter to the controller (not included).
- 4.Connect the AC load to the output port of the inverter (If you have many appliances, please just plug the AC socket to the inverter)
- 5.Turn on the inverter when the battery is full charged, then the system starts working.

Note: Pay attention to the polarity, please make sure to connect the right polarity to the controller and the inverter. Otherwise, the controller will be burnt out.

(5)On-grid system System Wiring

One-way connection method. Figure 7.5.1

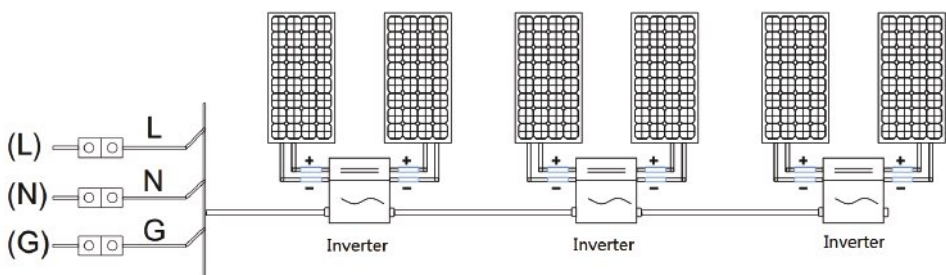
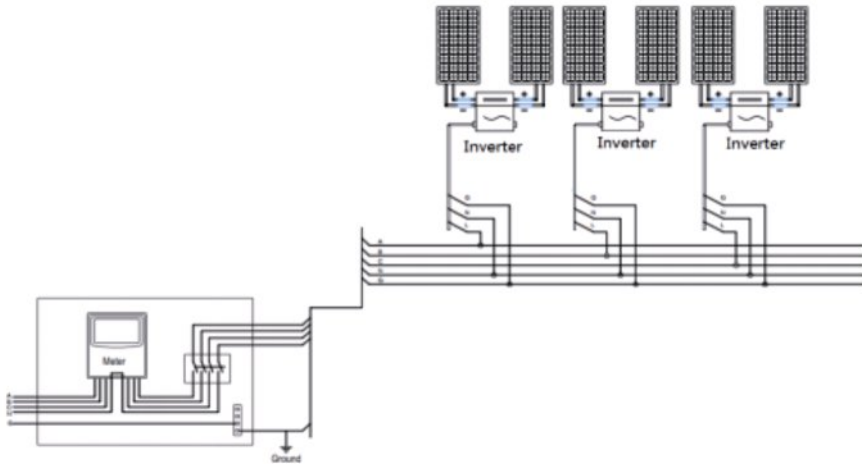

Figure 7.5.1





Three-way connection method. Figure 7.5.2

For details, please refer to the manual of on-grid inverter.

## 8. Inspection and Maintenance

Routine inspections and maintenance of solar panels are required, especially during the warranty period, which is the responsibility of the user. Any damage to the component should be notified to the supplier within two weeks.

### 8.1 Troubleshooting

If your installation does not work properly, please inform your installer immediately.

### 8.2 Testing The Solar Panel

#### 1) Open Circuit Voltage (VOC)

##### IMPORTANT:

- Make sure the multimeter measurement function is set to measure DC Volts and the test leads are connected to the correct port, which in this case are Volt and COM. If the meter reads OL (overload) during this

measurement, it means that meter must be set to a higher DC measurement range. Typical DC measurement ranges on the meters are (1) 0-20 VDC (2) 20-200 VDC (3) Above 200VDC. It depends on the Open-Circuit Voltage (Voc). For this module, the meter volt measurement range should be set to 20-200VDC.

- Disconnect the solar panel completely from the battery and regulator.
- While the solar panel is under the sunlight, measure the voltage by having the negative (COM) test lead that has been connected to the multimeter contacting the metallic part of the negative MC4 connector, and the positive test lead contacting the metallic part of the positive MC4 connector. If the reading on the multimeter is zero, then the junction box on the back of the solar panel should be opened with a flat-head screw driver so the measurement can be taken directly from the positive and negative terminals inside the junction box.

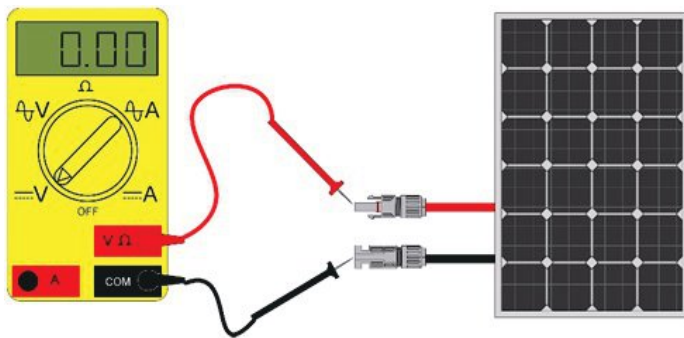

## 2) SHORT CIRCUIT CURRENT (ISC)

- **IMPORTANT:** Make sure the multimeter selection is set to measure DC Amps, and the test leads are in the correct port to measure DC Amps. The range of measurement should be set to ~10A.

- Disconnect the solar panel completely from the battery and regulator.
- While the solar panel is under the sunlight, measure the amps directly at the positive and negative MC4 connectors by having the negative (COM) test lead of the multimeter contacting to the metallic part of the negative MC4 connector and the positive test lead contacting the positive MC4 connector.

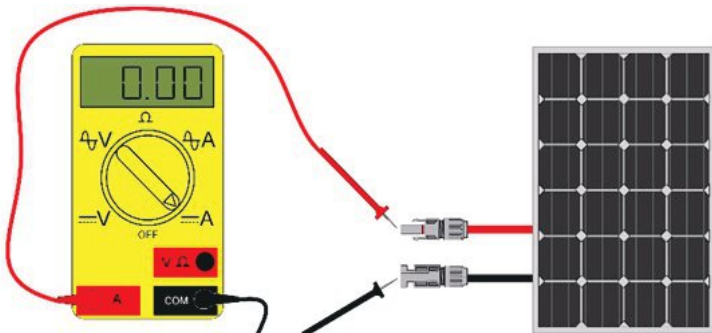

### 8.3 Cleaning and Maintenance

1. Do not scrub solar module with hard objects, scratched solar module glass surface lowers the conversion efficiency of the solar panel.
2. Cleaning of the solar array must be done thoroughly, leaving no place neglected or it may accelerate the aging of the solar cells or cause fire.
3. It is recommended to perform a preventive inspection every six months by qualified personnel without changing the components of the modules.

#### Cleaning Guideline:

1. Disconnect the wire connecting the solar panel to other objects.
2. Do not clean the glass with cold water while it is still hot to avoid thermal shock, which may shattered the module glass.
3. Only use non-abrasive material such as sponge or soft clothing to clean the glass surface of the assembly. Do not use hard object to scrape the glass.
4. Only use clean water for cleaning. Do not use chemicals.
5. The temperature difference between water used for cleaning and the module should be limited within the range of  $-5^{\circ}\text{C}$  to  $+10^{\circ}\text{C}$ .
6. The pressure of the water used for cleaning should be less than 1000 Pa.

