

ZEROXCLUB



ZEROXCLUB HD Wireless 10" Backup Camera System (BW104SL) Installation and Operation Guide

Any questions or suggestions please send an email to customer service via
sales@uszeroxclub.com

FOREWORD:

Thank you for purchasing this **ZEROXCLUB** product. **ZEROXCLUB** is committed to providing high-quality products and a pleasant shopping experience.

- Before operating this backup system, please read these instructions carefully and test it.
- Please keep this instruction manual in a safe place for future reference.
- If you have any questions, or if you require technical support, don't hesitate to get in touch with us at our service email address: sales@uszeroxclub.com
- We will respond within 24-hours to provide you with the support you require.
- Please keep these instructions or write down our email so that you can reach us if you have questions.

If you encounter the following:

1. When opened, it is found to be defective or missing parts;
2. You don't like it when you received;
3. Need technical support and help during the installation process;
4. Camera or monitor gets accident during use;
5. You order the wrong item;
6. Any other after-sales problems that need help.

Please contact us in time, we will provide you with the best service and technical support, and solve the problems.













This is our service Email: sales@uszeroxclub.com (We will reply to you within 24 hours.)

Contents

FOREWORD:	1
1 WHATS IN THE BOX?	3
2 INSTALL GUIDE	4
2.1 Installation Safety Precautions	4
2.2 Make an Installation Plan	4
2.3 Monitor Installation	5
2.4 Camera Installation	6
2.5 Power Monitor & Camera	7
3 SYSTEM DESCRIPTION	8
3.1 Main Screen Interface and button	8
3.2 SD Card Access Port	10
4 SYSTEM SETTINGS	10
4.1 Menu Description	10
4.2 PAIRING Settings	12
4.3 PICTURE Settings	14
4.4 MIR-FLIP Settings	14
4.5 MODE Settings	15
4.6 CAM-SETUP Settings	15
4.7 SYSTEM Settings	16
4.8 PLAY Settings	17
4.9 RECORD Settings	18
5 Troubleshooting	18
6 FAQ	23
7 General Information	26
8 Warranty	27

1 WHATS IN THE BOX?

Make sure you have the following listed items included in the packaging. If any item is damaged or missing, contact us at sales@uszeroxclub.com. It would be better if you wrote the order number from Amazon include photos of the damaged or missing part in your email, so that we can handle the problem much more quickly.

 <p><i>Monitor</i></p>	 <p><i>Rear Camera x2</i></p>	 <p><i>Side Camera x2</i></p>	 <p><i>Power Cord x5</i></p>
 <p><i>Car Charger</i></p>	 <p><i>Installation Kit</i></p>	 <p><i>Antenna x5</i></p>	 <p><i>Upgrade Bracket x2</i></p>
 <p><i>Sunshade</i></p>	 <p><i>U-shaped Bracket</i></p>	 <p><i>Fan-shaped Bracket</i></p>	 <p><i>User Manual</i></p>

2 INSTALL GUIDE

The system components are designed to be assembled without difficulty and with simple tools.

2.1 Installation Safety Precautions

- Use the correct size cable and connector to power the rear camera
- Ensure the power supply circuit has circuit protection
- Connect the rear camera to a 12-24V DC circuit only
- Use insulated tools when working with power supply
- Use correct safety equipment when working at elevated levels
- Ensure correct polarity of 12V DC power supply to the camera.
Red = Positive.Black=Negative.
- Do not allow water to enter the LCD Display.
- Excessive heat can be caused by a loose connection.

2.2 Make an Installation Plan

We recommend that you make a plan before you begin the installation of your system components. This approach will eliminate the likelihood of running into problems with cable routing, camera mount locations, and power supply.

* Please test the system before installation with temporary mounting and wiring to make sure it can work well. (the method of powering the monitor and cameras refer to 2.5)

2.2.2 Suggested Installation Sequence

Based on our experience, we recommend that you follow this installation sequence:

- Assemble Installation Tools
- Install the Monitor
- Connect Monitor to the Power Supply
- Install the Camera(s)
- Connect Camera(s)' Red&Black Wire(s) to the Power Supply
- Test and Calibrate the System
- Adjust the Camera(s) Views
- Secure the Camera(s)' Power Cord

2.3 Monitor Installation

Choose a mounting location in the cab of the vehicle that will not block your view and that complies with local traffic laws.

1. The monitors come with a Fan-shaped windshield bracket and and a U-shaped bracket.

◆ U-shaped Bracket Installation:

1. Lay the screen face up, put the bracket on the fixed directions as the white dotted lines shows



2. Screw the knob bolts, then you can fix or adjust the screen angle



◆ Fan-shaped Bracket Installation:

The angle can be adjusted as needed. A sticker is included for mounting the screen on the dashboard or windshield.



2. Once mounted, position the monitor to a comfortable viewing angle.
3. Using the cigarette lighter cable included with your kit, plug the monitor into the vehicle's power supply.

2.4 Camera Installation

1. Determine the mounting location for the camera

Installing cameras on a non-prepped RV requires some drilling. Be aware of what you' ll be drilling into.

Additionally, when choosing a mounting location, make sure there won' t be any obstacles blocking your view once the camera is installed. If you' re mounting the rear camera, we recommend installing it as high as possible.

2. Use the mounting bracket as a template to mark where your camera will be positioned. Then, drill a hole for the wiring.

3. Use the included screws to attach the camera bracket to your vehicle wall.

4. Be sure to install the antenna on the camera. Then, plug the male end of the camera power cable into the female connector wired into your vehicle, and finally, attach the camera to the bracket using the included screws. Adjust the camera angle as needed.

5. Connect the camera wires.

Feed the DC female connector of the camera power cable through the freshly drilled hole, and connect the DC female to the DC male connector of the power cord, and then connect the red and black wires of the power cable to the nearest 12V / 24V power supply.

*If you are unable to identify your vehicle's positive and negative power cords, refer to your car user manual.

*For safety, make sure you do this while the car is turned off.

*Make sure you poke your positive red wire through the positive reverse light wire and the negative black wire through the negative reverse light wire.









1. Install the Rear Cameras		
1. Use the original bracket, and install it to the place you want.	2. Use the updated bracket, and install it to the place you want.	
		
2. Install the Side Camera		
1.Remove the screws of the camera	2. Open the housing of the camera to reveal the dome camera and the base. Fix the base in the car where it needs to be mounted	3.Rotate the dome camera to get the angle and image you want, then put the housing in place and tighten the screws.
		 <p>360° rotatable</p>
3. Connect the Power Cord		
Connect the Power Cord to camera, then power it		
		

*Before fixing the camera, you can adjust the lens of it.

2.5 Power Monitor & Camera

ZEROXCLUB INSTRUCTIONS MANUAL

Recommend to test system with temporary mounting and wiring before final installation.



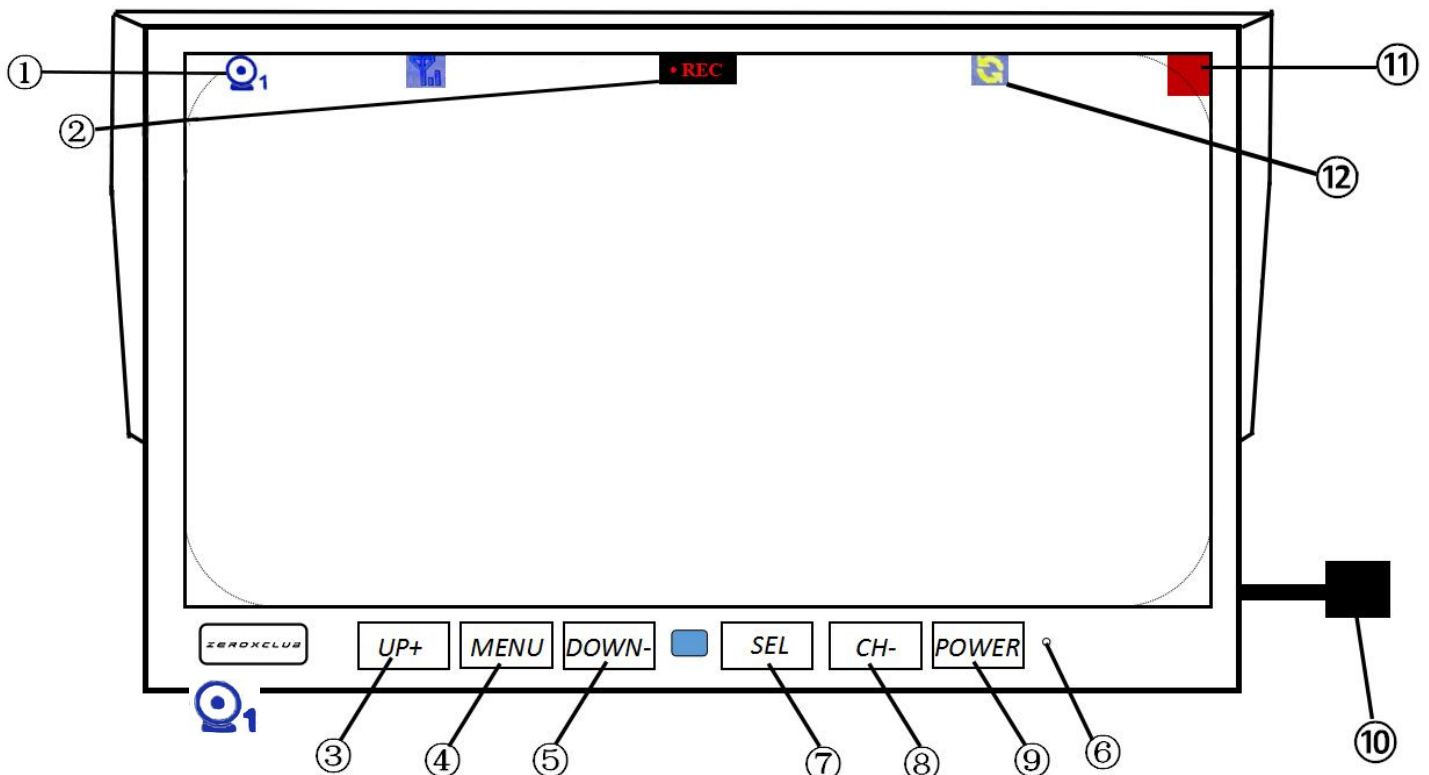

<p>① Mount the antennas to cameras and monitor</p>	<p>② Connect the power cord or car charger to camera and monitor</p>	<p>③ Power the camera and monitor</p>
		<p>Use Car Charger</p> 
		<p>Use Power Cord</p> 
		<p>Use Power Cord</p> 

3 SYSTEM DESCRIPTION

3.1 Main Screen Interface and button



ZEROXCLUB INSTRUCTIONS MANUAL

② 	REC: Recording video, there will be red REC in the upper-middle left of the display. In the event of SD card issues, re-format the SD card (RECORD menu).
③ UP+	A Function Increase button. Select forward in display operation
④ MENU	A Menu/Return button. Press to access menu or return to the previous panel.
⑤ DOWN-	A Function Decrease/Rotate button. Select backward in display operation. Press and hold for 5S to rotate.
⑥ Power Indicator Light	Power Indicator Light.
⑦ SEL	A Confirm/Recording button. Press to turn on/off recording. Or press this button to confirm.
⑧ CH-	A Channel Switch button. Press it to switch screen to single screen or split screen.
⑨ POEWR	A power button turns the display device on or off.
⑩ Power cord	Monitor Harness Connector
⑪ Red Tag	There is a screen protective film on the screen, it is used to remove it. Please be careful to remove it.
⑫ 	Rewrite: This shows this sign once you switched on the rewrite function.
	Red Lock: If the upper left side of the display shows the red lock , and the screen buttons cannot be operated indicating that the screen is locked. You need to press and hold the MENU button, and it will show the icon  , then press SEL button to confirm, the system will be unlocked.

Note: In split screen, the menu cannot be accessed, please press **CH-** to switch to single screen first.

Note: The **MENU** button cannot be operated to access the menu panel if the system is recording. Please press **SEL** first to stop recording.

Note: If everything is backwards, press and hold the **DOWN-** button a few seconds can rotate the screen.

Note: Repeated presses of **CH-** button will switch each camera channel on the screen as well as the dual camera channel or the quad camera channel (if Quad Split Screen mode is turned on).

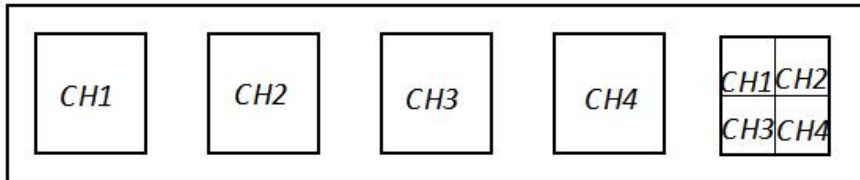

3.2 SD Card Access Port

An SD card access port is located on the top right side of the monitor. The SD card is the primary storage device on the monitor, onto which camera video imagery is captured. You just need to press the memory card hard and it will pop out or get stuck in. The monitor contains a 32GB SD Card.

(This system support up to 128GB SD card.)

(1)  **Memory card protection:** Try to slide the little yellow tab if you can't write data and format it on the computer.



(2) If the system does not recognize the memory card, a prompt will pop up on the right side of the screen: **NO CARD**. Please try to reinsert the memory card or format the memory card.

4 SYSTEM SETTINGS

4.1 Menu Description

There are eight primary menu selections.

- Selected menu item highlights in yellow color.
- Press MENU Button won't bring up the main menu when in split-screen mode/recording mode.
- Use Function Increase Button or Function Decrease Button to select the menu item.
- SEL Button: means select, press it to activate the selected item.

ZEROXCLUB INSTRUCTIONS MANUAL

- Sub-menu items may highlight in red color.
- To return from any selection press the MENU button or wait for a timeout.

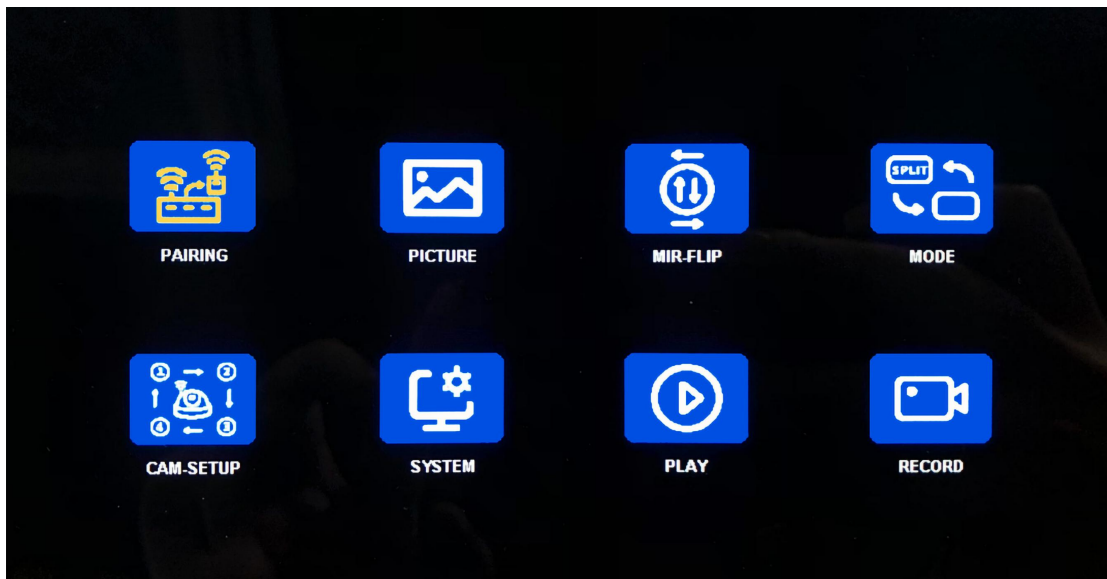

Software Management System Panels and Sub-panels

Icons in the Main-panel	Sub-panels
Pairing	Set up which cameras are assigned to which numbers,#1 through #4, then pair them
Picture	Brightness, Contrast, Hue, Volume(invalid)
Mir-flip	Normal, Mirror, Flip, Mir-flip
MODE	Split1-2, Split1-3, Split1-4, Split2-3, Split2-4, Split3-4, Quad, H-split, Split-off
Cam-setup	CAM1: on/off, CAM2: on/off, CAM3: on/off, CAM3: on/off
System	Time, Language, Color-sys, Auto-dim, P-line
Play	Play recorded videos
Record	Rewrite, Format

NOTE: (1) Menu main panel won't bring up while monitoring in split-screen mode.

* Please press the "CH-" button to switch it to full screen before using the "MENU" button to enter the menu panel. Otherwise "MENU" button won't work.

- (2) “**POWER**” button not working while playback of the video files.
- (3) Re-start recording the second file when you switch channels.
- (4) The content displayed on the screen is the content recorded by the system.

4.2 PAIRING Settings

This is a pairing icon, you can refer to the pairing steps to pair the camera and monitor.

Press **MENU** → Go into **PAIRING** → **SEL** → Begin to count down

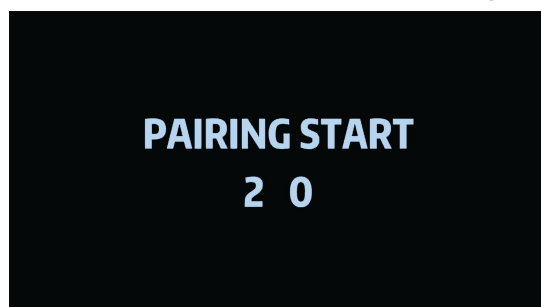

Before installing the cameras, you have to decide which cameras will be paired with which channel numbers so that the screen displays the ideal channel grouping when making channel selections. (If you need to renumber the cameras, you can re-pair them, see 4.2.1 for the pairing procedure).

* According to the actual situation, you can:

1. Turn on or off a certain camera via CAM-SETUP settings. For example, if you choose to close #1, the camera's image will no longer be displayed. (Path: Menu - CAM-SETUP - Turn ON/OFF the camera channel)
2. Select split-screen mode via MODE settings. There are a variety of split-screen modes to choose from and only support 2 or 4 cameras displayed at the same time. (Path: MENU - MODE - Choose split mode)

4.2.1 Pairing Steps

1. Disconnect the power to the unit and then keep the camera and monitor within 3 feet when pairing.
2. Ensure the antennas of the cameras are connected and tightened.
3. Reconnect the monitor and turn it on. Press **CH-** button to select a

channel that needs to be paired. (single screen displays CAM 1/2/3/4).

4. Press the **MENU** button to enter menu interface and select PAIRING, press **SEL** to confirm, you will have 20 seconds for pairing.

5. The screen appears "Pairing Start" and begins to count down, then please plug in the power of the camera. (**NOTE: Do not plug the camera into the power until the pairing count-down has already started.**)

6. During this time, you just keep powering the system and waiting for the countdown clock, the system will pair up automatically.

4.2.2 Pairing Notes

*Before leaving the factory, the camera has been paired with the screen

*Camera pairing can be redone as needed so that the cameras are paired with specific camera channel. (For example, if the rear camera shows on channel 1, but you want it to display on channel 2, you can switch the screen to channel 2 then refer to 4.2.1 to pair the rear camera with screen channel 2.)

*If you lose signal reception, re-pair the camera. (The screen will show "NO SIGNAL".)

* Please make sure that the monitor and camera have antennas installed.

* Please make sure that the camera's view has been opened via **Menu--CAM-SETUP**.

* When pairing, please keep the camera and monitor within 3 feet.

(1) If you want to add one more camera, you need to press the **CH-** button to switch to the CAM 1/2/3/4 for single screen, then pair the camera with the monitor by repeating the pairing steps, one camera at a time.

(2) Please make sure that you only power this camera, and disconnect other cameras to avoid the signal will be affected by others. Only one camera is paired at a time.

(3) Repeat the steps again if it is unsuccessful. The pairing must be completed within 20 seconds, otherwise, you need to retry pairing steps

(4) If failed, please observe the monitor and camera are powered (cover the infrared sensor to create the low light condition, then the infrared lights on each side of the camera will turn on).

(5) Powered the monitor firstly, finally powered the camera.

4.3 PICTURE Settings

The screen BRIGHTNESS/ CONTRAST/ HUE/VOLUME settings are found in the “PICTURE” section and adjust the BRIGHTNESS/ CONTRAST/HUE/VOLUME slider to the desired level.

Press **MENU** → Go into **PICTURE** → Press **SEL** → Press **UP+/DOWN-** to select to adjust the BRIGHTNESS/CONTRAST/HUE → Press **SEL** → **UP+/DOWN-** to adjust the value

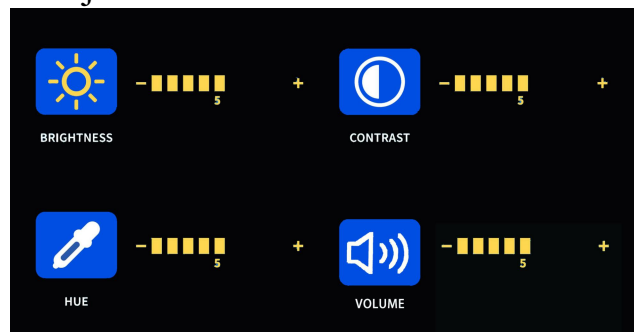

Note: Volume has no operational effect. Because the system does not have a microphone, it cannot record sound.

NOTE: Press **MENU** once to return to the menu, press twice to return to the camera view.

4.4 MIR-FLIP Settings

Allows you to mirror the video.

Press **MENU** → Go into **MIR-FLIP** → **SEL** → Press **UP+/DOWN-** button to choose the flip-style you want)

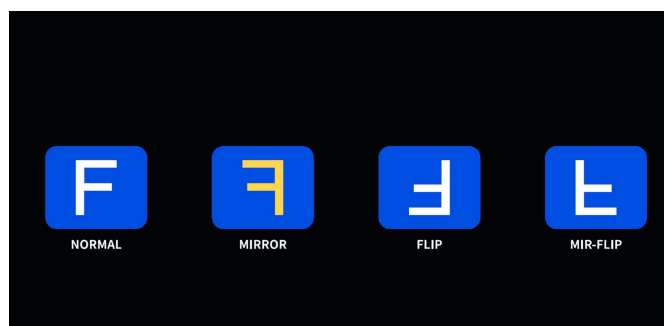

- Control camera mirroring and flipping, on a per camera basis.
- You can flip up and down or mirror the image of a certain camera according to your needs:

NORMAL	The screen remains normal (default).
MIRROR	The image is flipped left and right.
FLIP	The image is flipped upside down.
MIR-FLIP	After the image is flipped left and right, it is flipped up and down again.

4.5 MODE Settings

Control display split-screen mode setting.

Press **MENU** → Go into **MODE** → **SEL** → Press **UP+/DOWN-** to select the split mode you want → Press **MENU** to return the previous panel.

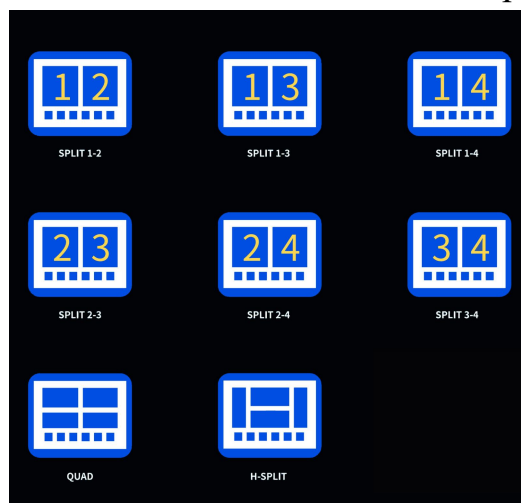

4.6 CAM-SETUP Settings

You can choose from CAM 1, CAM 2, CAM 3, CAM 4

Press **MENU** → Go into **CAM-SETUP** → Press **SEL** to confirm → **UP+/DOWN-** to choose ON or OFF the CAM screen → **SEL**

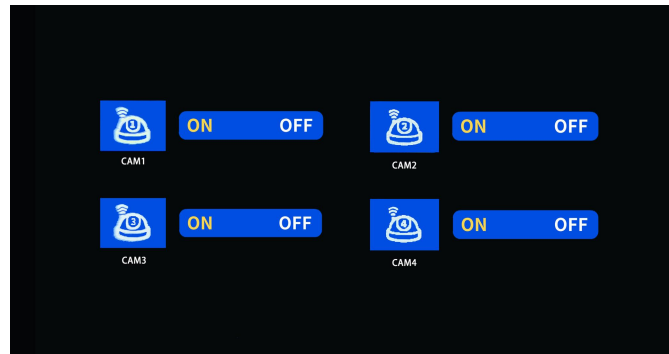

- You can select the next one by pressing the **UP+/DOWN-** button, the other operation steps are the same.
- If you want to see the camera from a certain numbered screen, you have to make sure it has been turned ON in this menu, so that it can display the image.

NOTE: Press **MENU** once to return to the menu, press twice to return to the camera view

4.7 SYSTEM Settings

More advanced display settings are available in the "System" page, such as TIME, LANGUGE, COLOR-SYS, Auto-Dim, P-LINE.

Press **MENU** → Go into **SYSTEM** → **SEL**

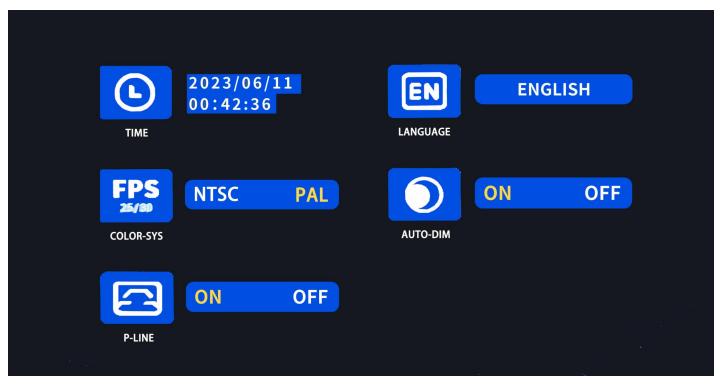

COLOR-SYS	Ignore this function
AUTO-DIM	When this option is "ON", the monitor will automatically increase the brightness when there is low light. Or you can set this option to "OFF". Auto Dimming Function.
P-LINE	If you need to display the parking guide on the camera screen, you need to switch the screen to the single screen display of the camera screen and turn on P-LINE. In this way, this camera screen will

	<p>display the parking guideline. You need to turn on the guidance lines separately for each backup camera.</p> <p>NOTE: If P-LINE is not turned on for the other screen channels, the parking guidelines will not be displayed.</p>
--	---

4.8 PLAY Settings

You can playback the recorded videos on the monitor, or playback on the computer by reading the memory card data on the computer.

Press **MENU** → Go into → **PLAYBACK** → **SEL**

- Play recorded video files on the monitor, refer to **Pic 3** for operation.

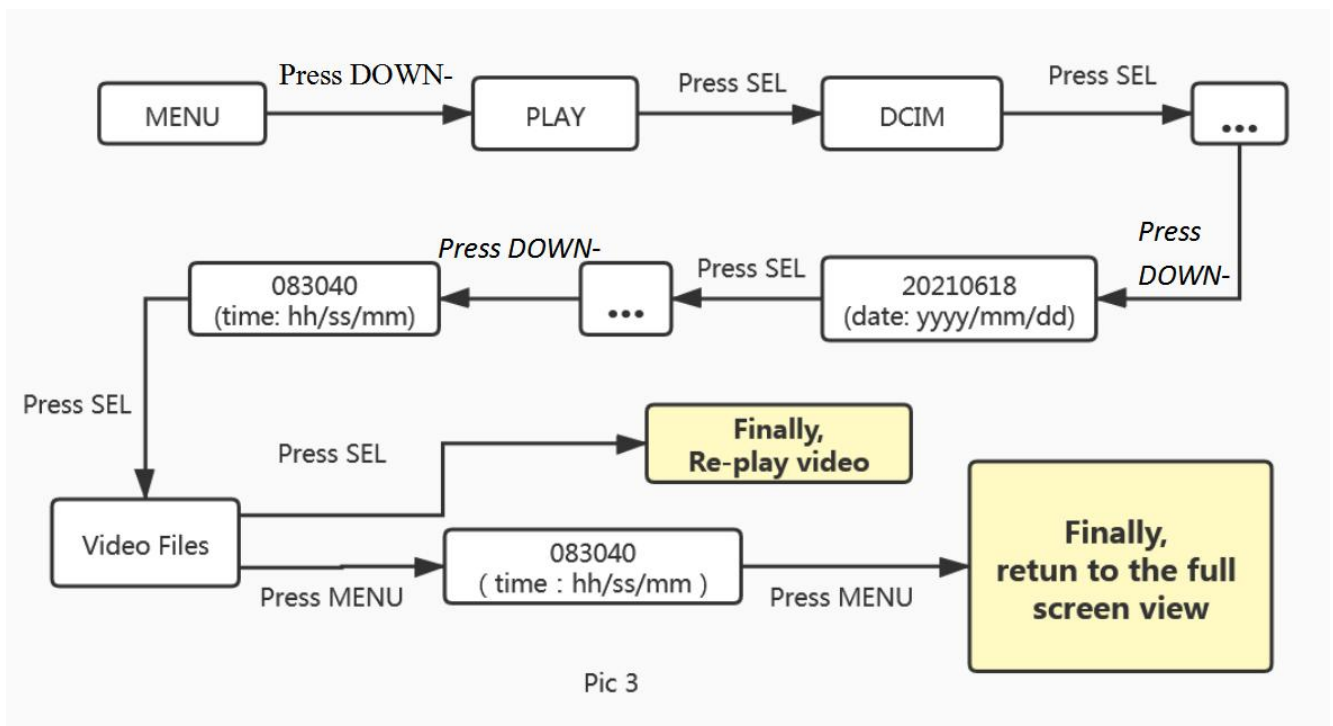

- ① When under DCIM, please press the **SEL** button to confirm and enter it.
- ② After entering DCIM, you will see the recorded video files, press the **UP+/DOWN-** button to select the file which you want to open, and then press the **SEL** button to confirm it.
- ③ After entering the video file, you will see the videos, press the **UP+/DOWN-** button to select the file which you want to open, and then press the “**SEL**” button to confirm it.

- ④ When you open the video, press the **SEL** button to play it, and you can press the **SEL** button to replay the video after the playback is over.

4.9 RECORD Settings

Memory card settings: REWRITE, FORMAT.

Press **MENU** → Go into **RECORD** → **SEL**

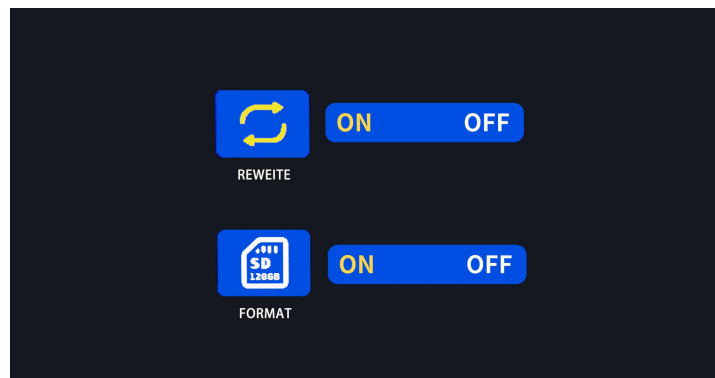

REWRITE	It will automatically overwrite the previous videos when the SD card is full. If you turn it on, please remember to save the video file in time if you need it to avoid it being overwritten.
FORMAT	It will clear all data in the system. If not turned off, the system will always be formatted. (Please copy out the useful recording material first to avoid losing important videos before formatting.) NOTE: If you turn it on, the formatting will be always happening.

- Recording only records what's on the screen, it can't record all cameras unless in split-screen mode. (*Recording does not start until press the SEL button)

NOTE: Press **MENU** once to return to the menu, press twice to return to the camera view

5 Troubleshooting

The display is blurred	➤ Check the external lenses. Fix this by gently wiping off the dirt.
-------------------------------	--

	<ul style="list-style-type: none"> ➤ Check if there any loose or faulty connections triggering such mishaps. ➤ There is moisture inside the camera's lenses, please contact us in time at sales@uszeroxclub.com with the picture of the issue and your Amazon Order ID
<p>Pictures overexposed/wash out</p>	<ul style="list-style-type: none"> ➤ Check whether the camera is pointed at the sky (light source)? If so, please adjust it so that it no longer looks directly at the light source. <p>Note: when the screen is exposed, the brightness may not be adjusted. Please try to avoid this situation.</p> <ul style="list-style-type: none"> ➤ If the picture does not improve after adjustment, there may be a problem with the camera, please contact us at sales@uszeroxclub.com with the pictures of the issue and Amazon order number.
<p>Black screen/the display can not turn on</p>	<ul style="list-style-type: none"> ➤ If the car engine has not been started, start the car engine ➤ If the light is off, it may be that the voltage is insufficient. Make sure the camera system can get the power 12V-24 V. Try another power supply. ➤ Check the vehicle battery if is good and replaced it. ➤ Check if the camera power lead hooked up wrong ➤ It may have a ground problem with the initial wiring. Hook up a separate power supply or run a different power wire. ➤ Check if the cigarette lighter is normal?

	<p>Try another cigarette lighter or connect the screen with another power cord.</p> <ul style="list-style-type: none"> ➤ Check the display to ensure that it is powering. Check if the power button on the display will light up. and press the monitor's power button waiting 2-4 seconds then to see if there is any image? If the camera is fine and there are words on the screen, it is disconnected ➤ If it still can't work well after try, please contact us in time at sales@uszeroxclub.com with the picture of the issue and your Amazon Order ID, we will help you solve it.
<p>Camera stop working</p>	<ul style="list-style-type: none"> ➤ Could you please check the camera that if get power? Reconnect the camera and cover the camera's sensor (like a light on the camera) with your finger and check if the camera's IR lights are on. If the light is not on, the camera is not getting power, please check the wiring or replace the power supply. ➤ Check if the positive and negative connections are reversed when connecting the red and black wires. ➤ Pair the camera and the monitor again. ➤ Check the wiring in the correct wiring connection. ➤ The power supply range is not between 12-24V (try other power supplies). ➤ If the SD card is full, please reformat the SD card. ➤ Note: If you check the wiring or test with other power supply and it still doesn't

	<p>light up, please tell us the result and contact us at sales@uszeroxclub.com with your Amazon order ID</p>
<p>Monitor displays “No signal”</p>	<ul style="list-style-type: none"> ➤ Check if the camera unit is receiving power ➤ Re-pair the camera to the monitor, the pairing method refers to 5.2.1 (Please take care to disconnect the camera first and then connect it after the pairing countdown appears.) ➤ Check proper wiring to avoid loose and poor attachments and connections of wires, as this may affect the delivery of images. ➤ Please look at the camera to find if the antenna wire is off.
<p>The words and graphics in the device are upside down</p>	<p>Hold the DOWN- button a few seconds (Repeat several times until the graphics and word are normal.)</p>
<p>The display freezing</p>	<ul style="list-style-type: none"> ➤ Restart the screen ➤ Remove SD card out of the monitor screen and reformat before you put back in monitor. ➤ If it still can't work well after try, please contact us in time at sales@uszeroxclub.com with the video of the issue and your Amazon Order ID, we will help you fix it.
<p>There is a red lock icon in the upper left corner of the screen.</p>	<p>Hold the MENU button a few seconds, a yellow unlock appears to the right of red lock and then press the SEL button to confirm.</p>

<p>Monitor not responding to any of the buttons</p>	<ul style="list-style-type: none"> ➤ Remove the SD card, reboot the system, then check if the system is locked? ➤ Unlock the system: Hold the MENU button a few seconds, a yellow unlock appears to the right of red lock and then press the SEL button to confirm. ➤ If the system is recording, please press SEL to exit the recording to see if the buttons can operate. ➤ If it still can't work well after try, please contact us in time at sales@uszeroxclub.com with the video of the issue and your Amazon Order ID, we will help you fix it.
<p>The side mount camera has the wire that goes to the antenna is broke</p>	<p>Please contact us in time at sales@uszeroxclub.com with the picture of the issue and your Amazon Order ID, we will send a replacement side camera to you.</p>
<p>One camera is showing a purple/pink tint on screen</p>	<p>Please contact us in time at sales@uszeroxclub.com with the picture of the issue and your Amazon Order ID, we will help you fix it.</p>
<p>One camera has some condensation inside</p>	<p>Please contact us in time at sales@uszeroxclub.com with the picture of the issue and your Amazon Order ID, we will help you fix it.</p>
<p>The system says no SD card</p>	<ul style="list-style-type: none"> ➤ Format the SD card. ➤ Remove SD card out of the monitor screen. Put other available SD card into the monitor to test.

If you have any questions not mentioned above, just feel free to

email us at sales@uszeroxclub.com. We're always there for you!

6 FAQ

6.1 Q: Why is it soundless?

A: Due to sound holes will reduce the waterproof coefficient of the camera, so we didn't enable this feature.

6.2 Q: Why I can't choose "QUAD" by pressing the "CH-" button?

A: You should open all cameras in CAM-SETUP and make sure the quad split mode has been chosen.

6.3 Q: Why does the screen flicker?

A: 1. It may be caused by the current, please try/replace a stable power supply. (Power supply current 1-2A, DC 12+)
2. Check proper wiring to avoid loose and poor attachments and connections of wires, as this may affect the delivery of images.

6.4 Q: Why does the monitor not respond while pressing the "MENU" button on the quad screen mode?

A: The "MENU" button just works when the monitor stays on the full-screen mode. (Please press the "CH-" button to switch the screen to full screen before entering menu settings.)

6.5 Q: Why does The "MENU" button can't work?

A: Split-screen mode and the monitor was triggered by one of the cameras, then the menu can't be brought up. Please make sure the monitor conditions are: full screen and nor of the camera be triggered.

6.6 Q: How to switch to other cameras?

A: Press CH-

6.7 Q: Where is the Parking Guideline?

A: MENU → SYSTEM → P-LINE. (Before setting, please switch the screen on which you need to show the guideline to full screen.)

6.8 Q: What is REWRITE?

A: If turn it on, it will automatically overwrite the original video record

when the SD capacity is full.

6.9 Q: What is FORMAT?

A: When you turn it on, all recorded videos will be deleted and the formatting is always happening.

6.10 Q: How to start recording a video?

A: Press the "SEL" button once to record, a “**• REC**” label will appear and flash indicating that the recording is on. Press the "SEL" button again to stop recording. There is no this option on the menu (only the video image is seen), only controlled by the "SEL" button on the monitor.

NOTE: If the display shows which camera's view, it will record which camera, if the screen shows all cameras, it will record all cameras.

6.11 Q: Why does the signal bar fluctuate when I am driving?

A: When driving, signal reception may drop at times. Changing the angle of the antennas may improve it, keeping the tip of the antenna as far away from metal objects as possible. Also, other devices also will affect it. If this doesn't work, please get in touch with us at

sales@uszeroxclub.com

* There is a 10ft extended antenna for signal enhancement.

If you would like to try it, please ask us, we are willing to provide you for free.

6.12 Q: How to confirm whether the camera gets power?

A: Cover the camera's light sensor (like a light on the camera) with your finger. Does it light up the infrared light? (If yes, it means that the camera is successfully powered on. If not, it means that the camera has not been powered on. Please check the wiring or use another power source and power cord to test.)

6.13 Q: Why does the screen keep showing the sign “NO CARD”?

A: Please lose the SD card and insert it again, and format the SD card.

Note: Please format the SD card before using this system or other SD cards.

6.14 Q: The monitor emits smoke after connection

A: The positive and negative poles are connected in reverse and cause a short circuit. Please read the installation guide carefully before installation.

6.15 Q: Why doesn't the camera shine?

A: The night vision mode will automatically turn on in the dark environment.

6.16 Q: Why does the pairing fail?

- A:**
1. When pairing, the distance between the camera and the screen is too far. Make sure to keep it within 3 feet.
 2. Connecting the camera prematurely. Do not plug the camera into the power until the pairing count-down had already started.
 3. Loose connection. Confirm connections are tight and correct.
 4. The voltage is not enough 12V+

6.19 Q: What to do if I am missing accessories?

- A:**
1. List your missing accessories and attach pictures.
 2. Contact customer service email: sales@uszeroxclub.com and attach your Amazon order number and shipping address.

6.20 Q: How to use a backup camera kit longer in summer?

- A:**
1. Park your car in a cool place to escape the heat.
 2. If the temperature inside the car is too high, you can turn on the air conditioner to cool down.
 3. If time permits, we should first open the doors and windows to ventilate and cool down.
 4. Install the monitor in a place where it can be temporarily removed when not in use and installed when needed.
 5. Blocking the front glass can effectively reduce the temperature inside the car.
 6. Apply a film to the window to block the heat and ultraviolet rays inside the sun.

6.21 Q: How to unpair or re-pair the cameras?

A: Before installation, you just switch to the channel number and follow the **4.2.1** pairing steps to re-pair.

If you have installed, you need to unpower (unwire) the cameras and re-pair as above

6.22 Q: What is the part number of the compatible camera ?

A: The system supports up to 4 cameras. The compatible camera are **B09957S58J** (side camera) and **B07S7PZ44T** (rear camera)

6.23 Q: What frequency band does it use?

A: 2.4 GHZ

7 General Information

7.1 Introduction and Specifications

This camera system is intended for vehicle surrounding monitoring during driving.

It consists of 4 weather-rated cameras and a screen, as well as related accessories. Rear/front mount cameras and side mount cameras are different form factors. It requires the monitor to be connected to a 12-24 Volt Direct Current power source (Currently limited to 1~2A).

7.2 General Safety Warnings

Improper installation can cause personal injury or property damage. For assistance contact ZEROXCLUB customer service.

- Do not disassemble or attempt to repair any part of the camera system.
- There are no user-serviceable parts inside the ZEROXCLUB Rear camera system. Contact ZEROXCLUB customer service if the part is ever compromised
- Children should be supervised to ensure that they do not play with the appliance.
- To avoid an electrical shock hazard, relevant actions should be performed by qualified and certified professionals. Disconnect all sources

of power to the camera before installing.

- NEVER test when smoking. Never use a flame.
- To reduce the risk of fire, connect the camera only to a circuit provided with a maximum branch circuit over the current protection device.
- To avoid an electric shock injury or damage to the system, we recommend that a qualified technician with appropriate training and experience be obtained to perform this critical connection.

8 Warranty

ZEROXCLUB offers a full 24 months warranty and replacement policy. We also provide lifetime technical support to ensure that you enjoy your modern backup camera for many years to come.

To obtain warranty support, or if you are not satisfied in any way, or have any issues with your purchase, don't hesitate to get in touch with us first for help, we will try our best to make you satisfied.

We promise that you will receive the best service from us, and we will try our best to help you until your problem is solved.

Every message will be replied to within 24h. Our contact email is sales@uszeroxclub.com, you can write it down or add it to your address book.

ZEROXCLUB

Customer Support Email: sales@uszeroxclub.com