



Powerful ozone generators are designed for any equipment

**COMPREHENSIVE PROTECTION**



AMBOHR®, your reliable supplier of technical products as well as for OEM production.

AMBOHR® is a company specializing in the design and production of ozone generators, pump and health appliances.

We support a network of national and global partners with our experience and our qualified, multilingual staff. Partnership and long-term cooperation are very important to us.

We work closely with our partners to ensure that we understand and understand the needs of the market and are able to provide a quick solution to your needs. You too can benefit from an effective partnership with AMBOHR®.

We are very attentive to the needs of our customers and can thus constantly expand our product range. Customer service and a growing product range with an attractive price / performance ratio can be offered.

AMBOHR® is a registered trademark of AMBOHR ELECTRIC. With our special focus on product quality and customer service, all AMBOHR® products are rigorously tested and comply with the latest standards.

Let us know, we look forward to working with you.

### **Values Driven**

Integrity in all our dealings  
Respect for team(s) and people  
Contributing to the success of our customers  
Risk-taking, innovation and learning  
Long-term perspective  
100% accountability / 0 excuses.

### **Integrated Manufacturing**

Vertical integration is the cornerstone of AMBOHR as it places innovation, development, design, manufacturing, testing, and shipping all within our control. With Everything Under Control, we can ensure the highest quality and customer satisfaction.

### **Limited Lifetime**

Warranty With total control over engineering and manufacturing, we are able to guarantee the highest quality products on the market—products free of defects in material, workmanship, and design.



# A

## After Sales Services

- One year warranty and lifetime maintenance.

# M

## Multilingual Staff

- We support Global partners with our experienced and qualified, multilingual staff.

# B

## Bear Responsibility

- 100% accountability / 0 excuses.

# O

## Online 24\*7

- Online 24\*7 service to solve your problems

# H

## High Quality

- Our products have passed SAA, UL, CE, RoHS and other certifications...

# R

## Requests & Rest

- You make requests, and we do the rest.

## Integrated Ozone Generator CD SERIES



CD-160  
Page 7



CD-200  
Page 8



CD-220  
Page 9



CD-300  
Page 10



CD-300F  
Page 11



CD-301  
Page 12



CD-301F  
Page 13

## Integrated Ozone Generator Cell CDM SERIES



CDM-030  
Page 15



CDM-100  
Page 16



CDM-120  
Page 17



CDM-200  
Page 18



CDM-300F  
Page 19



CDM-523F  
Page 20



CDM-800F  
Page 21



SPA-124  
Page 22

## CD Ozone Generator Cell CDT SERIES



CDT-300  
Page 24



CDT-700  
Page 25



CDT-800  
Page 26

## OKAYOZONE CD SERIES

The CD series of ozone generators were designed by AMBOHR, the leader in reliability in ozone generator controls for over 20 years. AMBOHR Ozone generator cells use ozone core discharge of invention patent, including the integration design of ozone generator tube, ozone driving circuit, and air pump, they can provide stable and efficient output, easy to install and maintain. These compact ozone generators were created specifically to withstand the demanding environment of the any machine. Our compact ozone generators have a smaller footprint and save energy as well. The electrical packs of AMBOHR ozone generators are epoxy potted protecting them from harsh corroding environments and they produce stable ozone output over a wide range of temperatures.

## OVERVIEW

- Produces powerful oxidant.
- Disinfects water & air by killing viruses and biological contaminants.
- Reduces the use of chemical levels which means it saves you money.
- Low power consumption.
- Designed & tested specially for Water and Air.
- Available in AC110-120V, 220-240V, AC24V, AC12V, DC24V, DC12V, 6W.
- Small and compact unit.
- CE, & CQC certified.

## OUTSTANDING TECHNICAL PROPERTIES

- Integrated design three in one unit with driving circuit, ozone generator tube, and air pump
- Stable& efficient output
- Low noise
- Long working life
- ozone generator electrical pack epoxy potted
- Extra thick inlet/outlet barb to prevent breakage
- No air gaps, no exposed contacts & no corrosion.

## WHY AMBOHR OZONE GENERATORS ARE SUPERIOR

- Powerful ozone generators are designed for any machine.
- Unique design CD Ozone Cell with solid High shock, vibration and drop resistant stainless-steel electrode for exceptional longevity.
- Thick, built-in mounting tabs for easy installations.
- Compact and smaller footprint.
- Double Insulation rated.
- High shock, vibration and drop resistant.
- Cool operation with low heat generation.
- Super low production & field failure rates.
- Enclosure & inlet/outlet barbs are made with UV /Ozone resistant plastics.



**OVERVIEW**

- CD-160 produces powerful oxidant.
- CD-160 disinfects water & air by killing viruses and biological contaminants.
- CD-160 reduces the use of chemical levels which means it saves you money.
- Low power consumption.
- Integrated design three in one unit with driving circuit, ozone generator tube and air pump.
- Stable & efficient output
- Small and compact unit.
- Low noise
- Long working life
- CE, & CQC certified.

**DIMENSIONS**

(Standard Configuration)

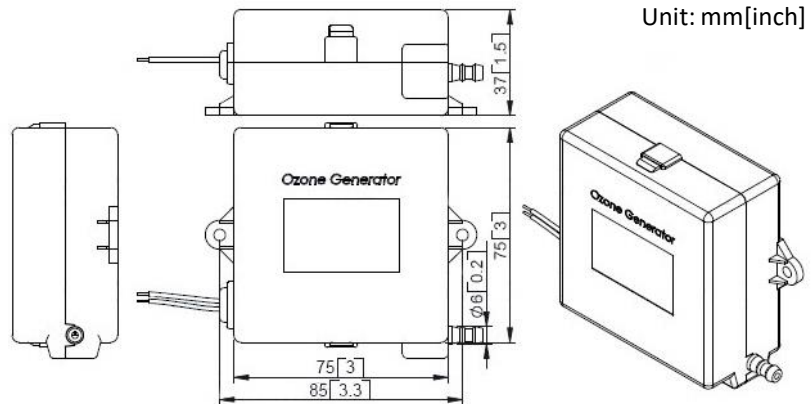

**TECHNICAL DATA**

Model No.:	CD-160
Ozone Output:	50-100 mg/hr
Pump Output:	1-2 L/min, >10 Kpa
Ozone Generating Method:	Corona Discharge
Electrical:	AC110-120V, AC220-240V, AC24V, AC12V, DC24V, DC12V, 6W
Outlet Connection:	Φ 6mm pagoda joint (1/4" barb)
Case:	ABS
Accessory:	Hose +Air stone (Optional)
Dimension(LxWxH):	3.0"*3.0"*1.5" (75 * 75 * 37 mm)
Installation Dim:	3.3" (85 mm)
Net Weight:	0.25kg

Note: Kit includes 1 ea. CD-160 Ozone Generator, 1 ea. installation manual and individually packed.  
 \* Custom ozone outputs, input power connectors and private labels are available upon request.



### OVERVIEW

- CD-200 produces powerful oxidant.
- CD-200 disinfects water & air by killing viruses and biological contaminants.
- CD-200 reduces the use of chemical levels which means it saves you money.
- Low power consumption.
- Integrated design three in one unit with driving circuit, ozone generator tube and air pump.
- Stable & efficient output
- Small and compact unit.
- Low noise
- Long working life
- CE, & CQC certified.

### DIMENSIONS

(Standard Configuration)

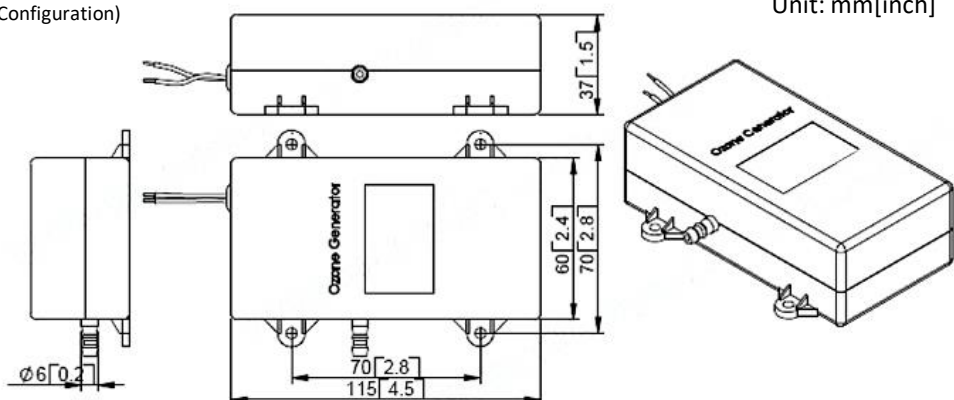

### TECHNICAL DATA

Model No.:	CD-200
Ozone Output:	150-200 mg/hr
Pump Output:	1-2 L/min, >10 Kpa
Ozone Generating Method:	Corona Discharge
Electrical:	AC110-120V, AC220-240V, AC24V, AC12V, DC24V, DC12V, 6W
Outlet Connection:	Φ 6mm pagoda joint (1/4" barb)
Case:	ABS
Accessory:	Hose +Air stone (Optional)
Dimension(LxWxH):	4.5"*2.4"*1.5" (115 * 60 * 37 mm)
Installation Dim:	2.8"*2.8" (70*70 mm)
Net Weight:	0.28kg

Note: Kit includes 1 ea. CD-200 Ozone Generator, 1 ea. installation manual and individually packed.

\* Custom ozone outputs, input power connectors and private labels are available upon request.



### OVERVIEW

- CD-220 produces powerful oxidant.
- CD-220 disinfects water & air by killing viruses and biological contaminants.
- CD-220 reduces the use of chemical levels which means it saves you money.
- Low power consumption.
- Integrated design three in one unit with driving circuit, ozone generator tube and air pump.
- Stable & efficient output
- Small and compact unit.
- Low noise
- Long working life
- CE, & CQC certified.

### DIMENSIONS

(Standard Configuration)

Unit: mm[inch]

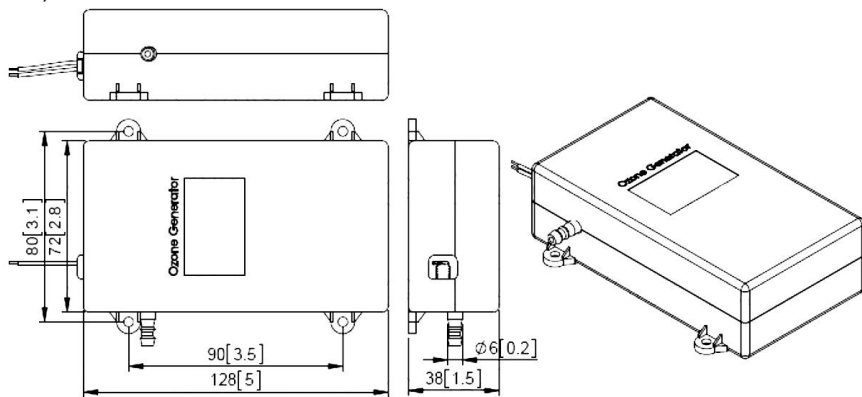

### TECHNICAL DATA

Model No.:	CD-220
Ozone Output:	160-240 mg/hr
Pump Output:	2-3 L/min, >10 Kpa
Ozone Generating Method:	Corona Discharge
Electrical:	AC110-120V, AC220-240V, AC24V, AC12V, DC24V, DC12V, 6W
Outlet Connection:	$\Phi$ 6mm pagoda joint (1/4" barb)
Case:	ABS
Accessory:	Hose +Air stone (Optional)
Dimension(LxWxH):	5.0"*2.8"*1.5" (128 * 72 * 38 mm)
Installation Dim:	3.5"*3.1" (90*80 mm)
Net Weight:	0.35kg

Note: Kit includes 1 ea. CD-220 Ozone Generator, 1 ea. installation manual and individually packed.

\* Custom ozone outputs, input power connectors and private labels are available upon request.





### OVERVIEW

- CD-300 produces powerful oxidant.
- CD-300 disinfects water & air by killing viruses and biological contaminants.
- CD-300 reduces the use of chemical levels which means it saves you money.
- Low power consumption.
- Integrated design three in one unit with driving circuit, ozone generator tube and air pump.
- Stable & efficient output
- Small and compact unit.
- Low noise
- Long working life
- CE, & CQC certified.

### DIMENSIONS

(Standard Configuration)

Unit: mm[inch]

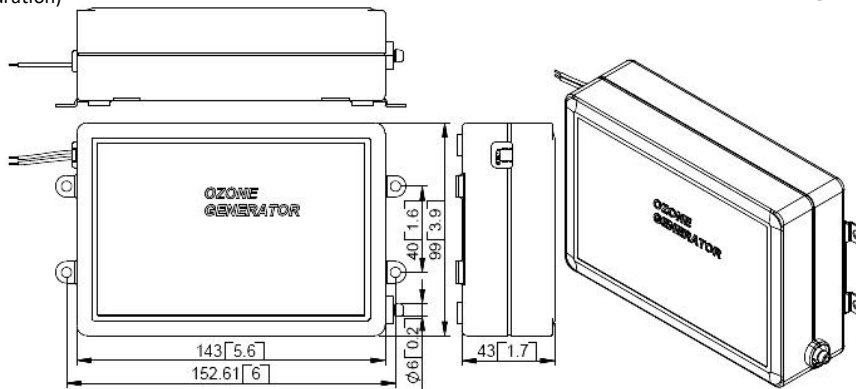

### TECHNICAL DATA

Model No.:	CD-300
Ozone Output:	200-300 mg/hr
Pump Output:	2-3 L/min, >10 Kpa
Ozone Generating Method:	Corona Discharge
Electrical:	AC110-120V, AC220-240V, AC24V, AC12V, DC24V, DC12V, 7W
Outlet Connection:	Φ 6mm pagoda joint (1/4" barb)
Case:	ABS
Accessory:	Hose +Air stone (Optional)
Dimension(LxWxH):	5.6"*3.9"*1.7" (143 * 99 * 43 mm)
Installation Dim:	6.0"*1.6" (152*44 mm)
Net Weight:	0.5kg

Note: Kit includes 1 ea. CD-300 Ozone Generator, 1 ea. installation manual and individually packed.

\* Custom ozone outputs, input power connectors and private labels are available upon request.



**OVERVIEW**

- CD-300F produces powerful oxidant.
- CD-300F disinfects water & air by killing viruses and biological contaminants.
- Increasing heat dissipation on the basis of CD-300F.
- Low power consumption.
- Integrated design three in one unit with driving circuit, ozone generator tube and air pump.
- Stable & efficient output
- Small and compact unit.
- Low noise
- Long working life
- CE, & CQC certified.

**DIMENSIONS**

(Standard Configuration)

Unit: mm[inch]

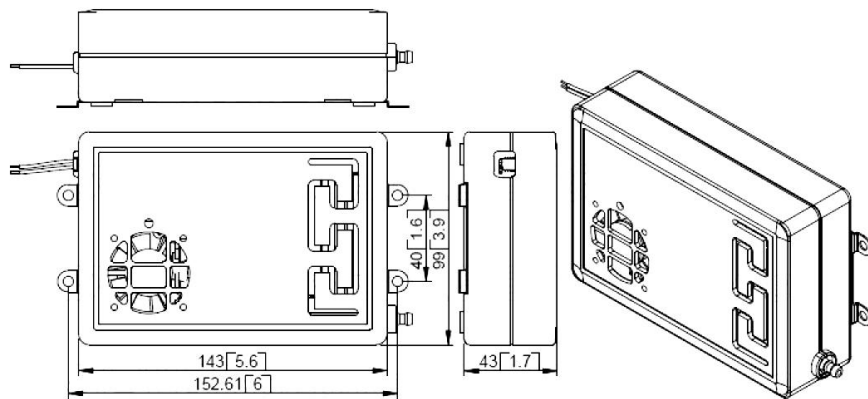

**TECHNICAL DATA**

Model No.:	CD-300F
Ozone Output:	300-400 mg/hr
Pump Output:	2-3 L/min, >10 Kpa
Ozone Generating Method:	Corona Discharge
Electrical:	AC110-120V, AC220-240V, AC24V, AC12V, DC24V, DC12V, 10W
Outlet Connection:	Φ 6mm pagoda joint (1/4" barb)
Case:	ABS
Accessory:	Hose +Air stone (Optional)
Dimension(LxWxH):	5.6"*3.9"*1.7" (143 * 99 * 43 mm)
Installation Dim:	6.0"*1.6" (152*40 mm)
Net Weight:	1.1 lbs (0.5kg)

Note: Kit includes 1 ea. CD-300F Ozone Generator, 1 ea. installation manual and individually packed.  
 \* Custom ozone outputs, input power connectors and private labels are available upon request.



**OVERVIEW**

- CD-301 produces powerful oxidant.
- CD-301 disinfects water & air by killing viruses and biological contaminants.
- CD-301 reduces the use of chemical levels which means it saves you money.
- Low power consumption.
- Integrated design three in one unit with driving circuit, ozone generator tube and air pump.
- Stable & efficient output
- Small and compact unit.
- Low noise
- Long working life
- CE, & CQC certified.

**DIMENSIONS**

(Standard Configuration)

Unit: mm[inch]

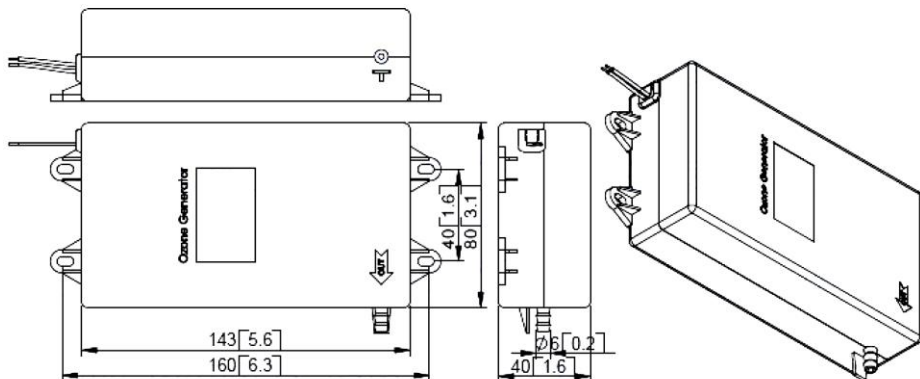

**TECHNICAL DATA**

Model No.:	CD-301
Ozone Output:	200-300 mg/hr
Pump Output:	2-3 L/min, >10 Kpa
Ozone Generating Method:	Corona Discharge
Electrical:	AC110-120V, AC220-240V, AC24V, AC12V, DC24V, DC12V, 6W
Outlet Connection:	Φ 6mm pagoda joint (1/4" barb)
Case:	ABS
Accessory:	Hose +Air stone (Optional)
Dimension(LxWxH):	5.6"*3.1"*1.6" (143 * 80 * 40 mm)
Installation Dim:	6.3"*1.6" (160*40 mm)
Net Weight:	0.41kg

Note: Kit includes 1 ea. CD-301 Ozone Generator, 1 ea. installation manual and individually packed.

\* Custom ozone outputs, input power connectors and private labels are available upon request.



### OVERVIEW

- CD-301F produces powerful oxidant.
- CD-301F disinfects water & air by killing viruses and biological contaminants.
- Increasing heat dissipation on the basis of CD-301F.
- Low power consumption.
- Integrated design three in one unit with driving circuit, ozone generator tube and air pump.
- Stable & efficient output
- Small and compact unit.
- Low noise
- Long working life
- CE, & CQC certified.

### DIMENSIONS

(Standard Configuration)

Unit: mm[inch]

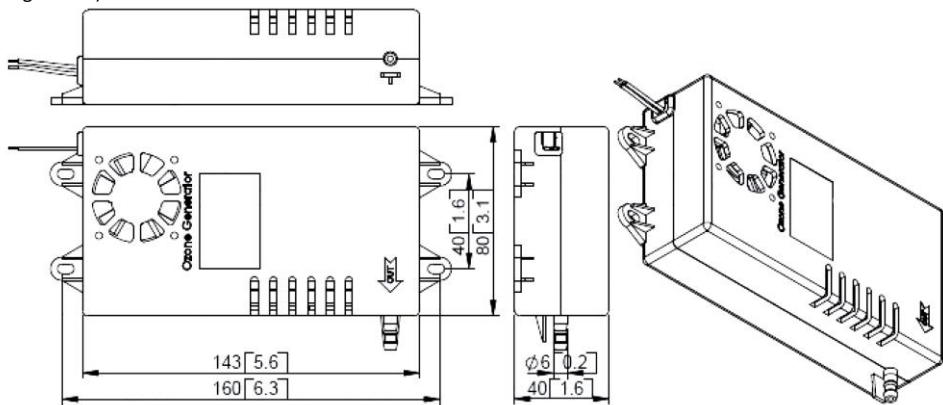

### TECHNICAL DATA

Model No.:	CD-301F
Ozone Output:	300-400 mg/hr
Pump Output:	2-3 L/min, >10 Kpa
Ozone Generating Method:	Corona Discharge
Electrical:	AC110-120V, AC220-240V, AC24V, AC12V, DC24V, DC12V, 10W
Outlet Connection:	Φ 6mm pagoda joint (1/4" barb)
Case:	ABS
Accessory:	Hose +Air stone (Optional)
Dimension(LxWxH):	5.6"*3.1"*1.6" (143 * 80 * 40 mm)
Installation Dim:	6.3"*1.6" (160*40 mm)
Net Weight:	0.43kg

Note: Kit includes 1 ea. CD-301F Ozone Generator, 1 ea. installation manual and individually packed.  
 \* Custom ozone outputs, input power connectors and private labels are available upon request.