



Elevated Trough Planter Box

Installation Guide

Thank You!

You're only a few steps away from your perfect vegetable garden or elevated planter. We hope you enjoy!

Model# E283612 / E283612G
Dimensions 36" L x 12" W x 28" H

Before You Start

Please read the instructions carefully to familiarize yourself with every detail and step involved. Keep this manual for future reference. Find a suitable space to assemble your new Elevated Trough Planter Box.

You need at least 37" x 13" (94 x 33cm) for the finished product. A flat and firm area (like a garage floor or flat yard space) is perfect! The only tool you may need is a rubber mallet.

Important Notes

Small parts are included; we advise you to keep them away from children and pets.

We also suggest having another person help you assemble. Maximum Load Capacity: approximately 3 cu. ft. of soil

★ [Subscribe at www.everbloom-garden.com](http://www.everbloom-garden.com)
for extra savings and upgrading information!



Everbloom-Garden.com

Questions or Comments?
Email us at service@everbloom-garden.com

Parts List

Elevated Trough Planter Box - 36" L x 12" W x 28" H

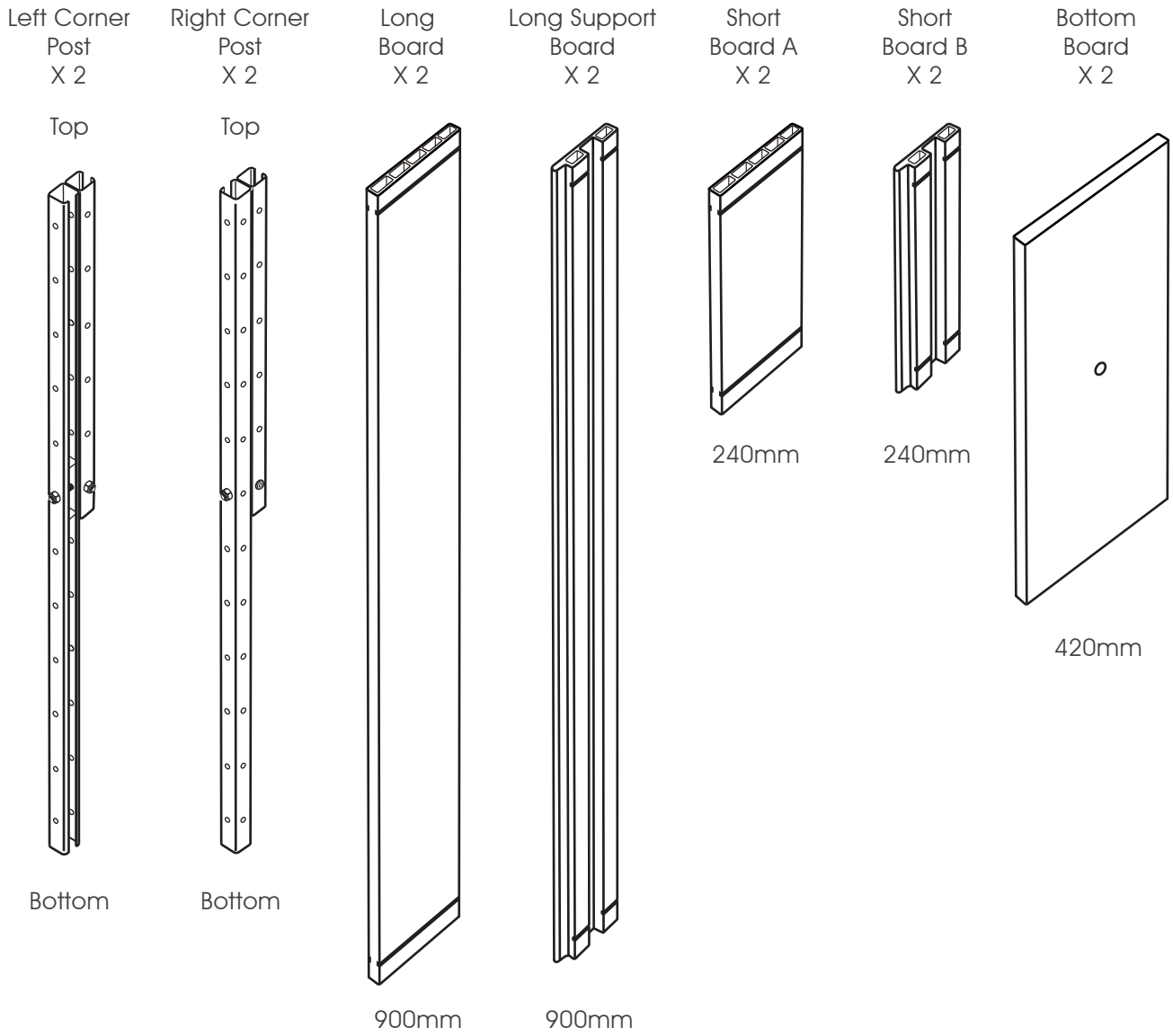

Post Cap
X 4

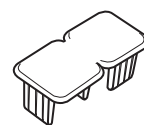

+ 2pc replacement

Garden Bed Liner
X 1

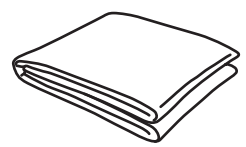

Assembly

Elevated Trough Planter Box - 36" L x 12" W x 28" H

There are 2 different assembly methods providing 2 different planting depths: 10" (as shown in Image 1) and 7.5" (as shown in Image 2).

* For deeper planting depth of 10", please follow steps from page 4.

* For easier but shallower planting depth of 7.5", please go to page 10.

IMAGE 1

Depth 1 - 10" from page 4

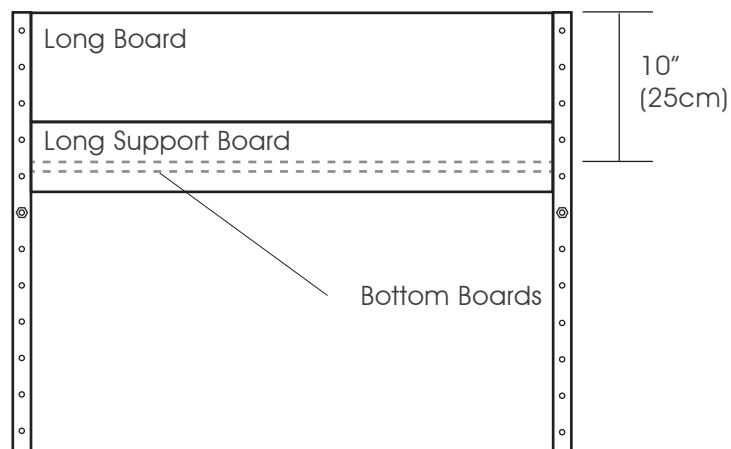
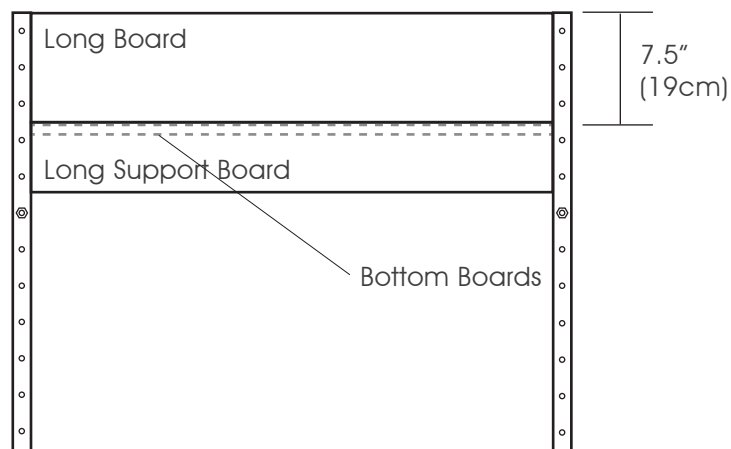

IMAGE 2

Depth 2 - 7.5" from page 10



Assembly

Elevated Trough Planter Box - 36" L x 12" W x 28" H

Start by making sure each corner post is oriented correctly, as shown in Image 3. Slide one short board B into the corner brackets from above.

Note: The short boards need to be placed in the inward "U" shape of the brackets, as shown in Image 4.

IMAGE 3

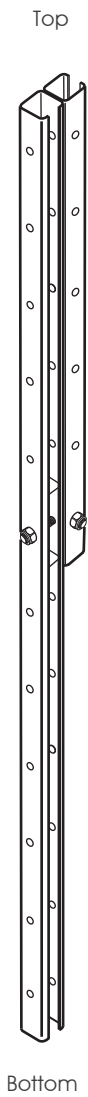
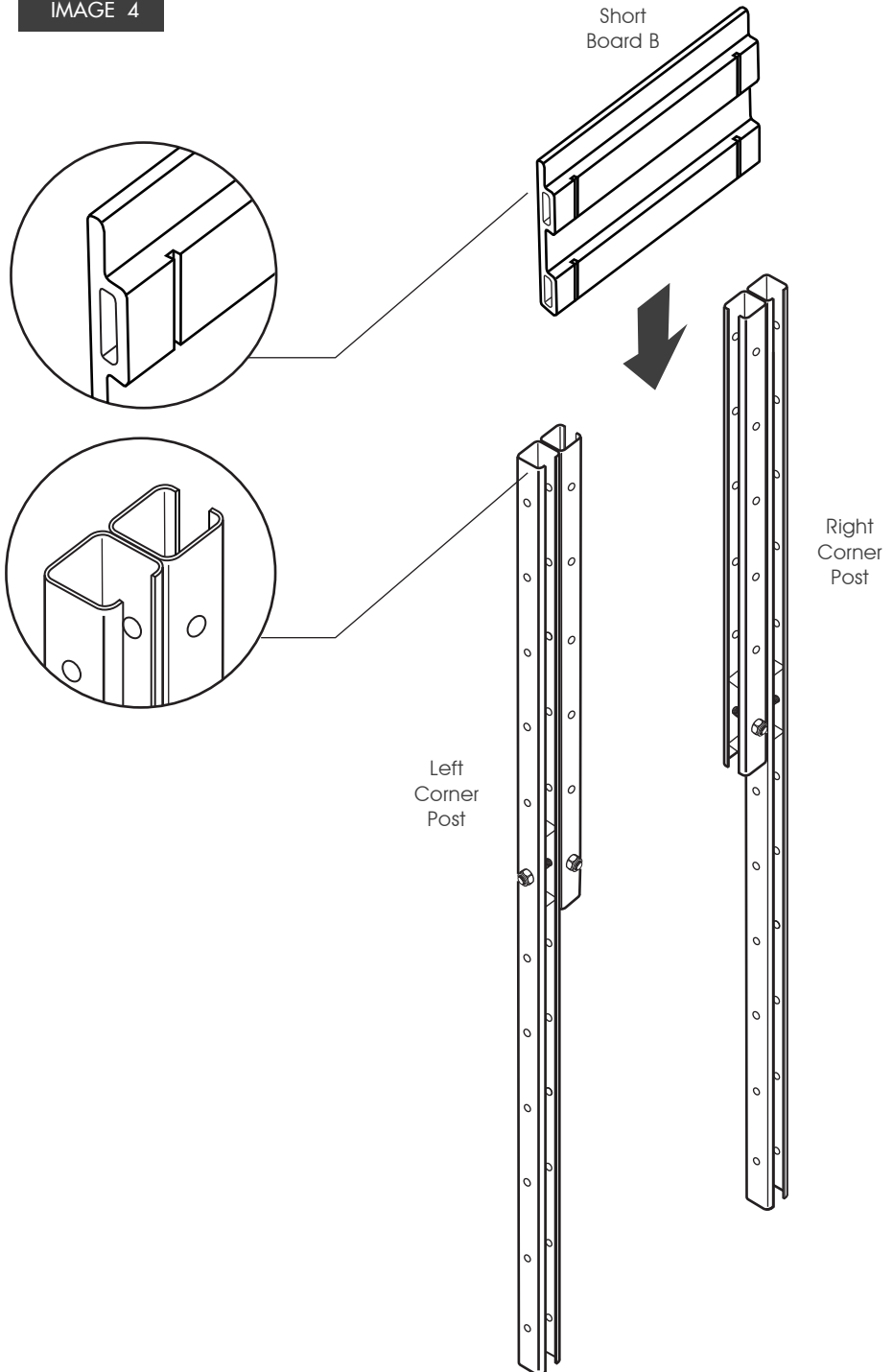

IMAGE 4



Assembly

Elevated Trough Planter Box - 36" L x 12" W x 28" H

Slide another short board B into the other two corner brackets from above, as shown in Image 5.

IMAGE 5

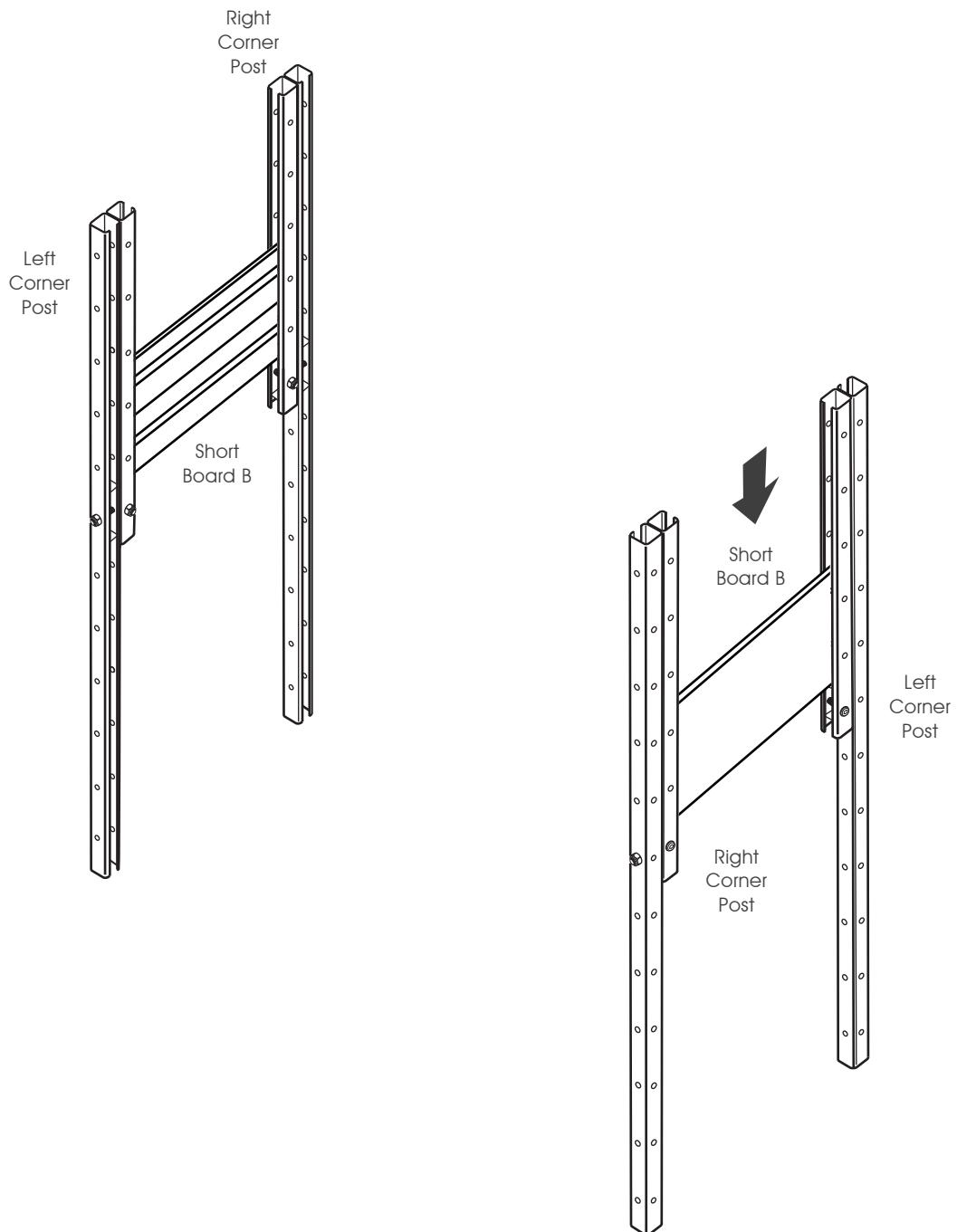

Assembly

Elevated Trough Planter Box - 36" L x 12" W x 28" H

With the help of another person holding the 2 assembled parts, slide the 2 long supporting boards into the brackets from above. Make sure that one support board goes straight to the bottom, while the other one stays in the middle of the way (don't push to the bottom), with the top edge between the 2nd and 3rd holes of the post.

IMAGE 6

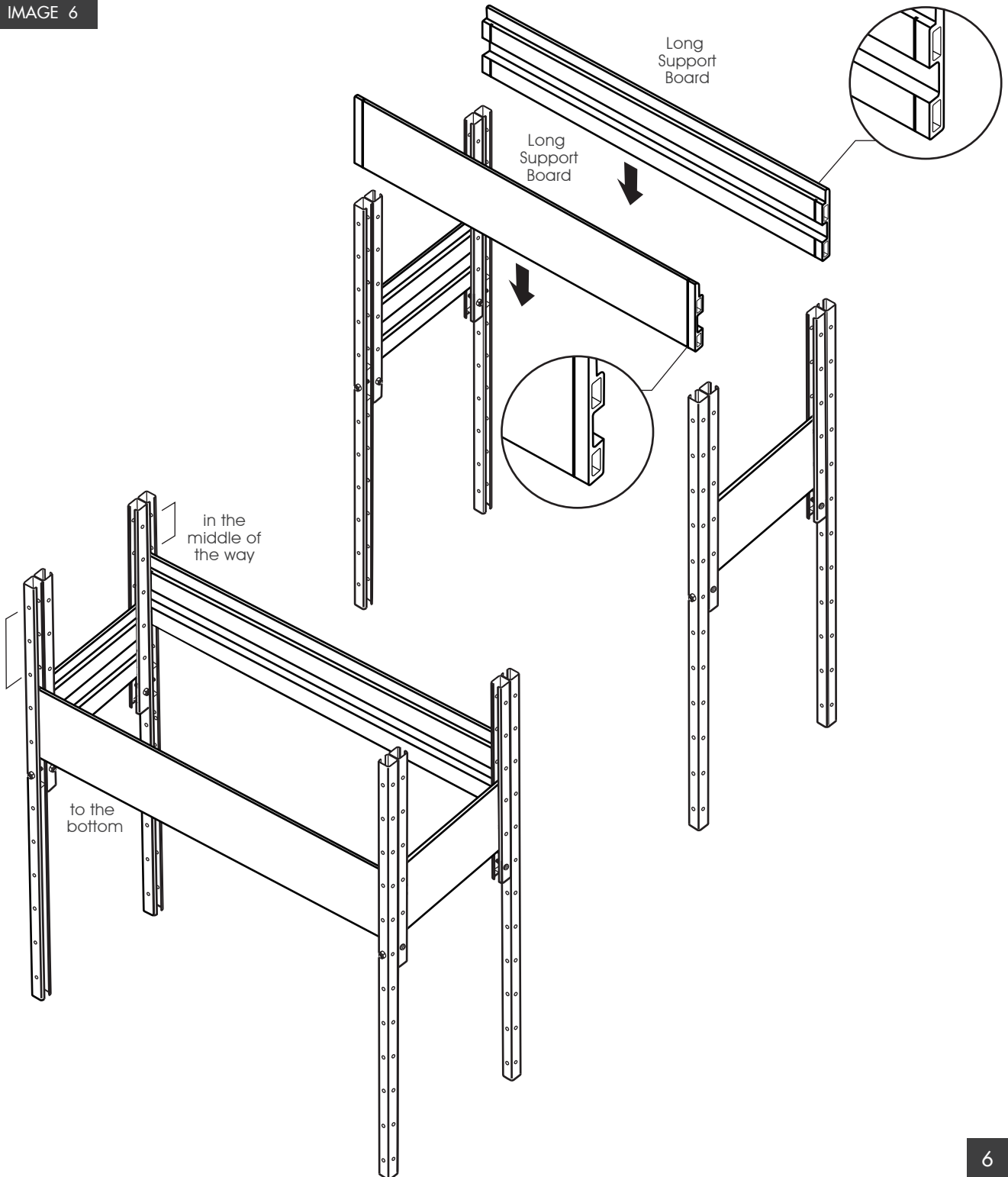

Assembly

Elevated Trough Planter Box - 36" L x 12" W x 28" H

Put the bottom boards on lower slots of long support boards. Make sure the 2 ends of these bottom boards go into the lower slots and rest in them with enough contact as shown in Image 7. Adjust the height of the higher long support board slightly to hold these bottom boards if necessary.

IMAGE 7

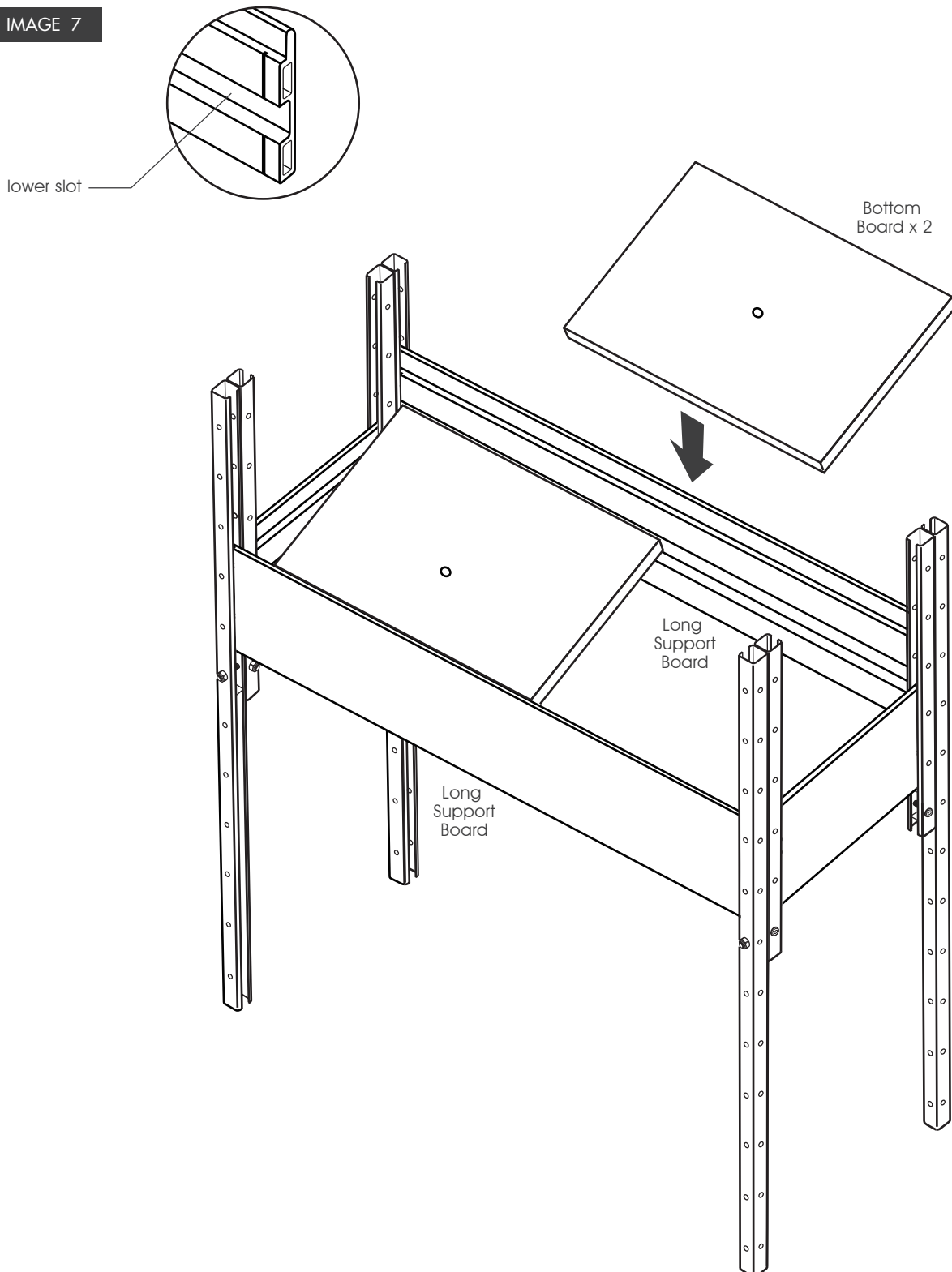

Assembly

Elevated Trough Planter Box - 36" L x 12" W x 28" H

Push down the higher long support board to the bottom, as shown in Image 8.

IMAGE 8

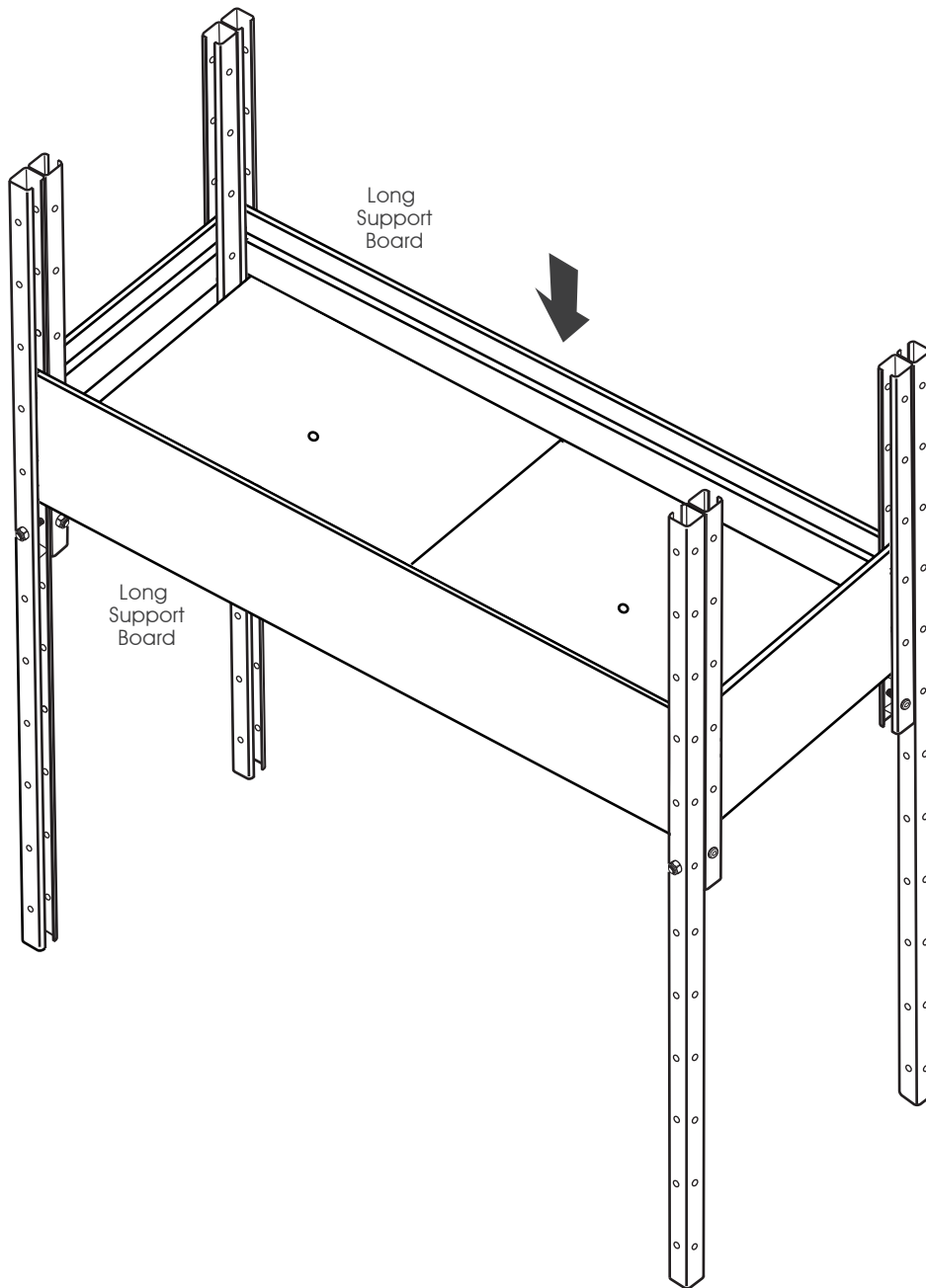

Assembly

Elevated Trough Planter Box - 36" L x 12" W x 28" H

Slide the remaining boards into place, as shown in Image 9. Now you get an elevated trough planter box with 10" planting depth. Then, go to page 15, and follow the steps afterwards.

Note: If you want to add trellis kit onto this bed, please assemble the extension connectors **before** this step, to avoid disassembling the boards later.

IMAGE 9

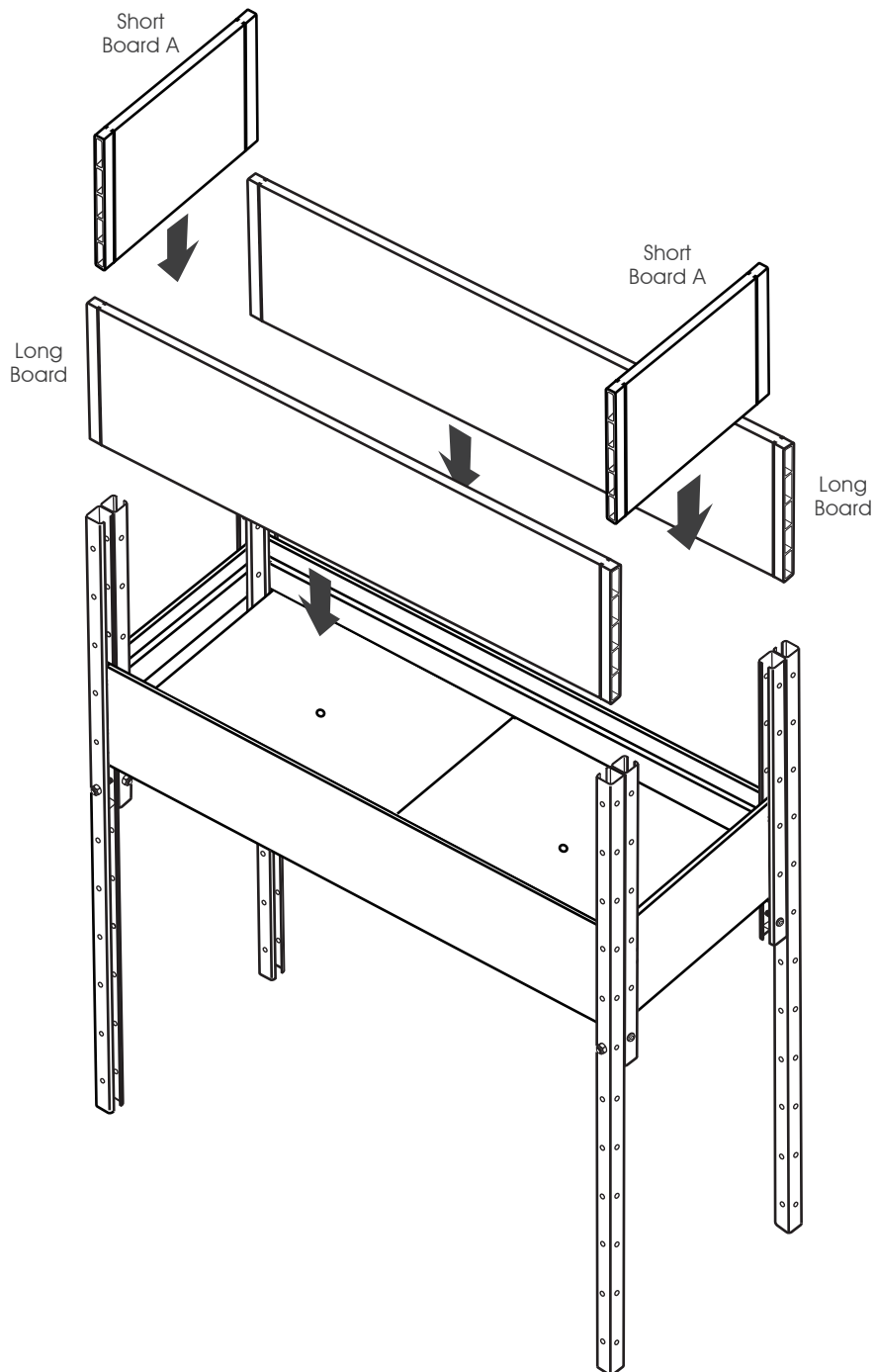

Assembly

Elevated Trough Planter Box - 36" L x 12" W x 28" H

Start by making sure each corner post is oriented correctly, as shown in Image 3a. Slide one short board B into the corner brackets from above.

Note: The short boards need to be placed in the inward "U" shape of the brackets, as shown in Image 4a.

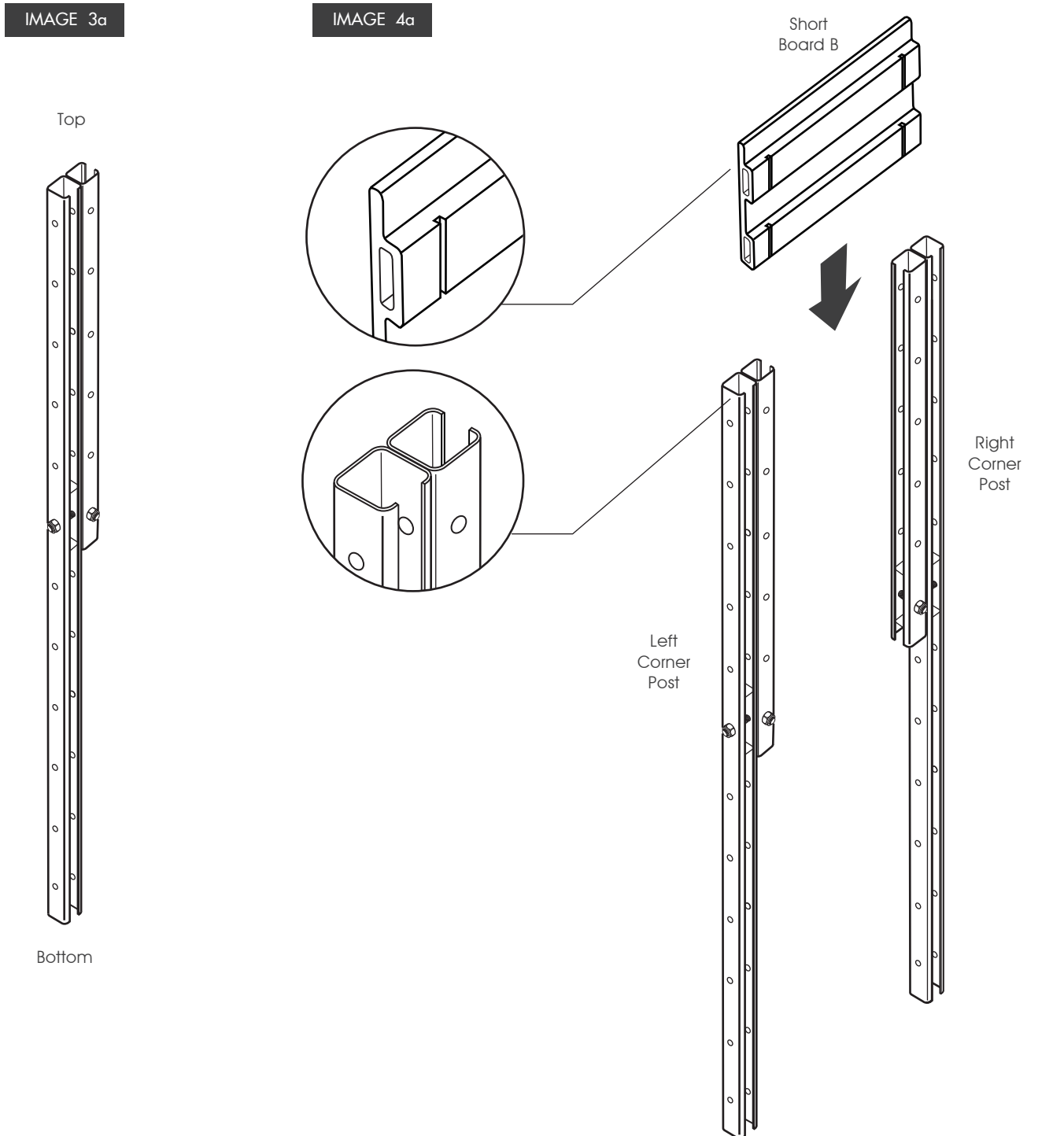

Assembly

Elevated Trough Planter Box - 36" L x 12" W x 28" H

Slide another short board B into the other two corner brackets from above, as shown in Image 5a.

IMAGE 5a

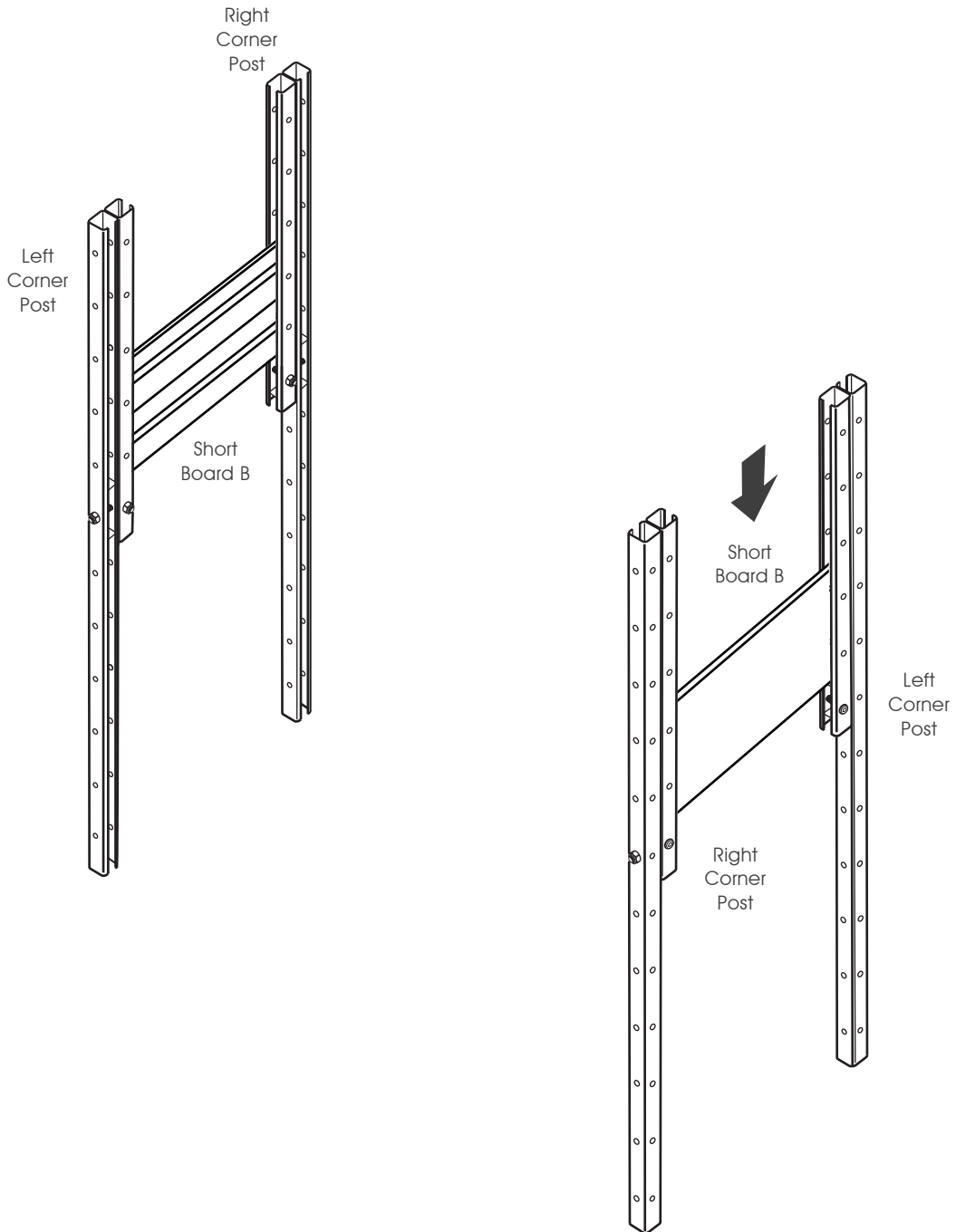

Assembly

Elevated Trough Planter Box - 36" L x 12" W x 28" H

With the help of another person holding the 2 assembled parts, slide the 2 long supporting boards into the brackets from above to the bottom, as shown in Image 6a.

IMAGE 6a

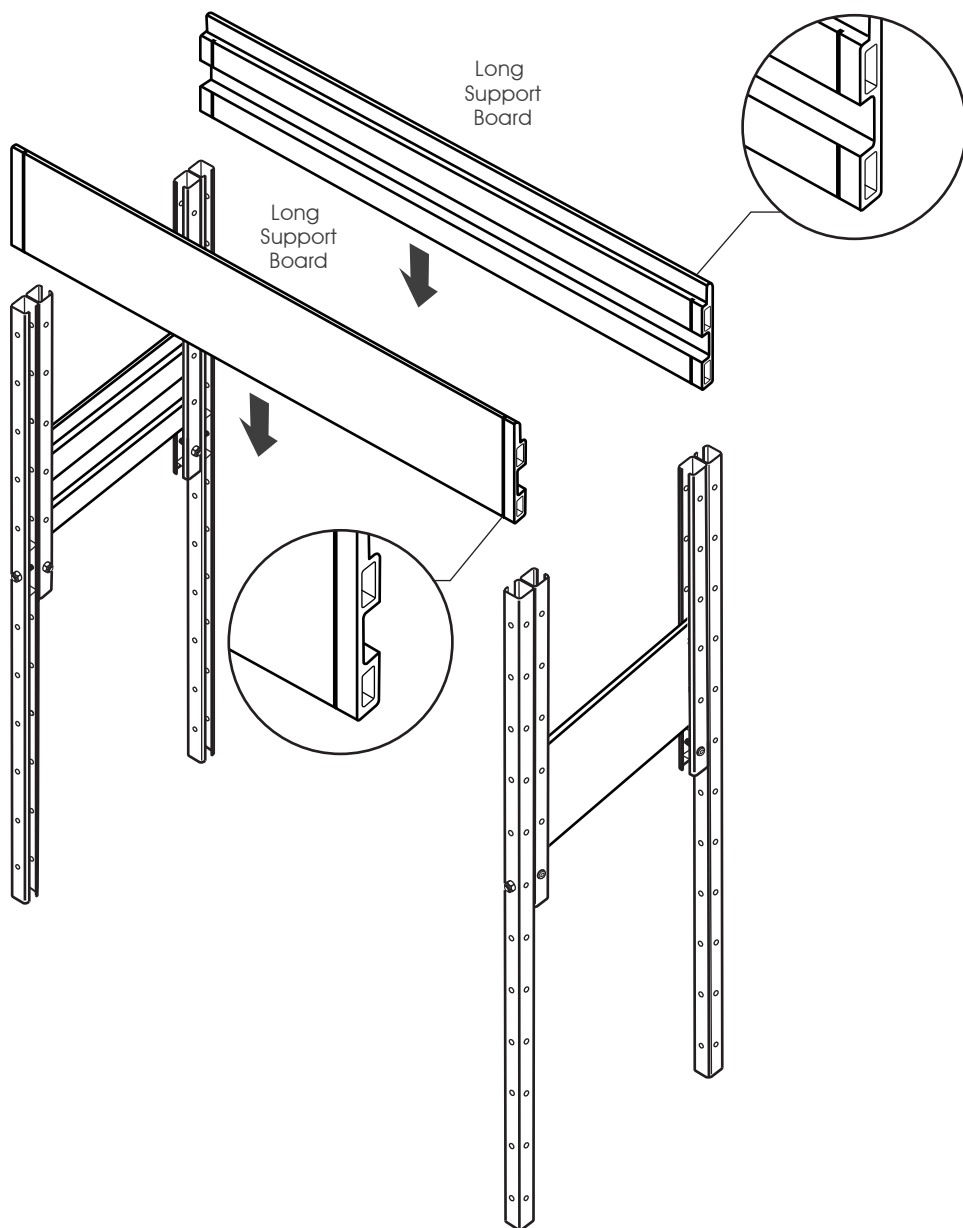

Assembly

Elevated Trough Planter Box - 36" L x 12" W x 28" H

Put the bottom boards on the long support boards, as shown in Image 7a.

IMAGE 7a

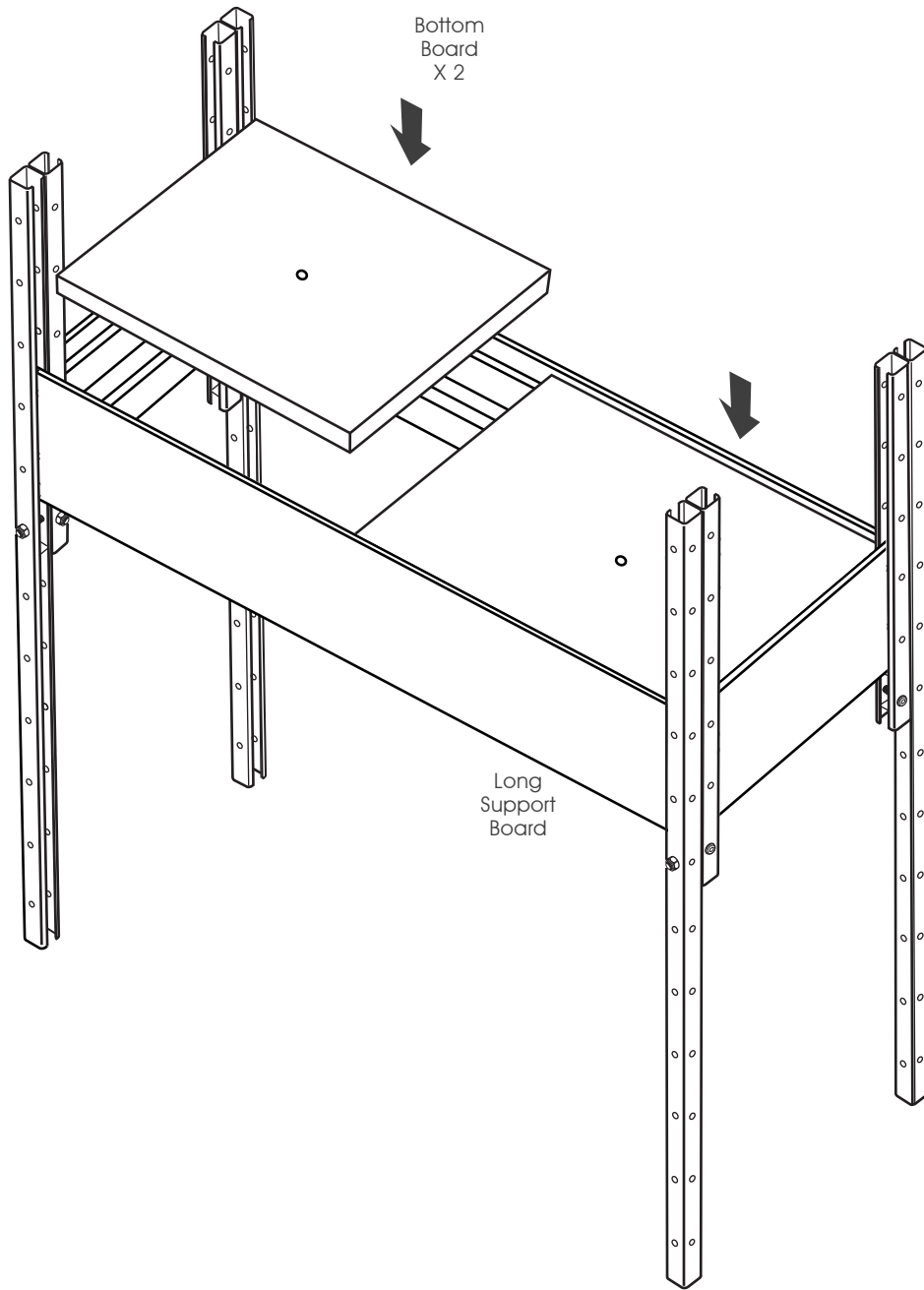

Assembly

Elevated Trough Planter Box - 36" L x 12" W x 28" H

Slide the remaining boards into place, as shown in Image 8a. Now you get an elevated trough planter box with 7.5" planting depth.

Note: If you want to add trellis kit onto this planter box, please assemble the extension connectors **before** this step, to avoid disassembling the boards later.

IMAGE 8a

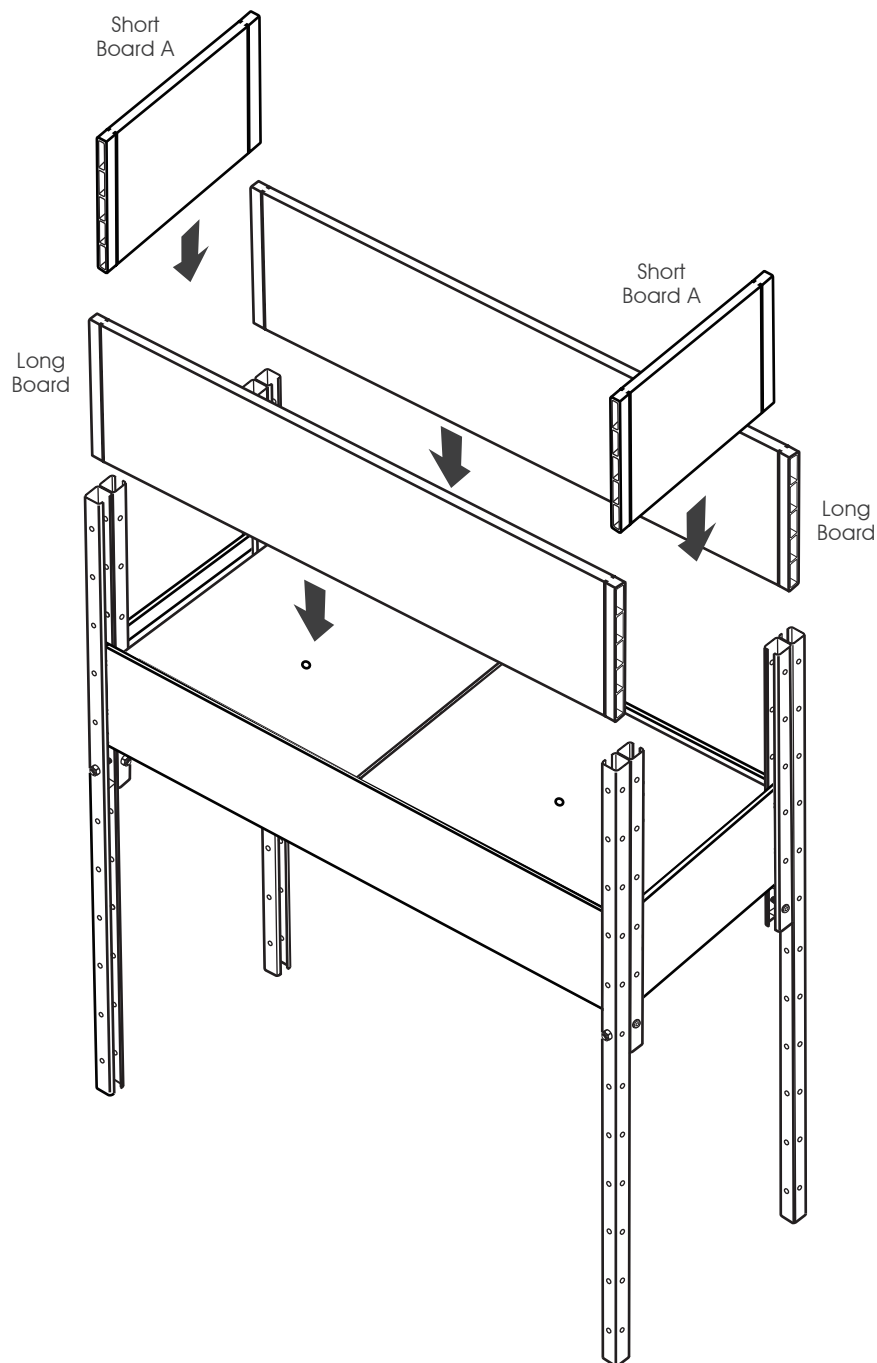

Assembly

Elevated Trough Planter Box - 36" L x 12" W x 28" H

If necessary, use your rubber mallet to ensure the boards are tightly in place. Cover the brackets with the 4 end caps, as shown in Image 10.

IMAGE 10

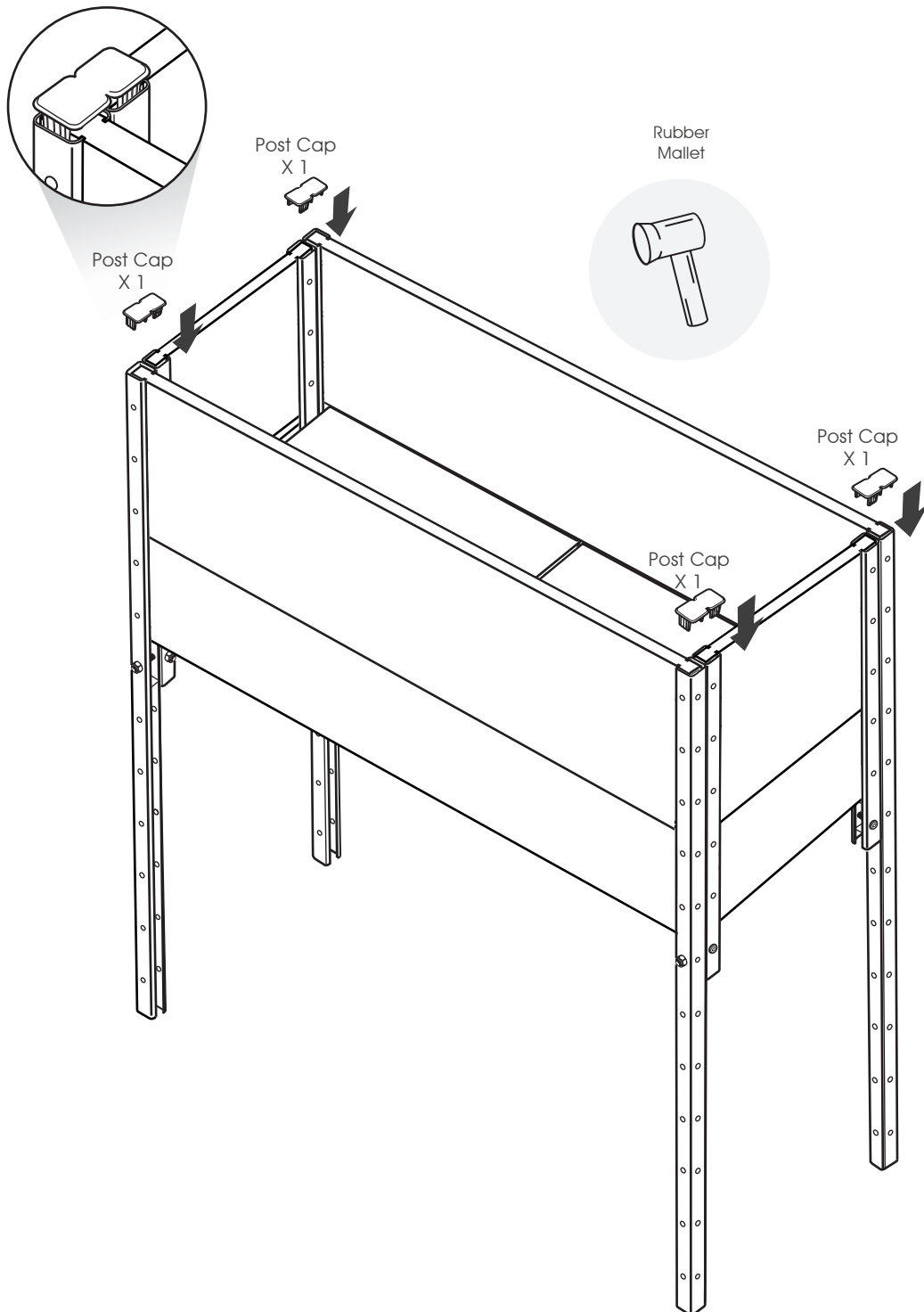

Assembly

Elevated Trough Planter Box - 36" L x 12" W x 28" H

For additional stability, we highly suggest using the included 8 self-tapping screws with washers (Image 11). Fasten 2 screws into each side of the inward facing corner posts using a #2 Phillips screwdriver (not included), as shown in Image 12.

Screws also can be fastened from outside, as shown in Image 13.
Do not fasten the screws into the same height holes facing to each other on the same post.

IMAGE 11

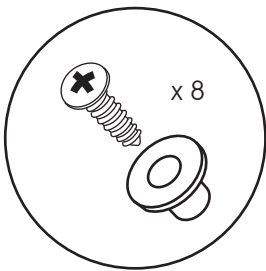

IMAGE 12

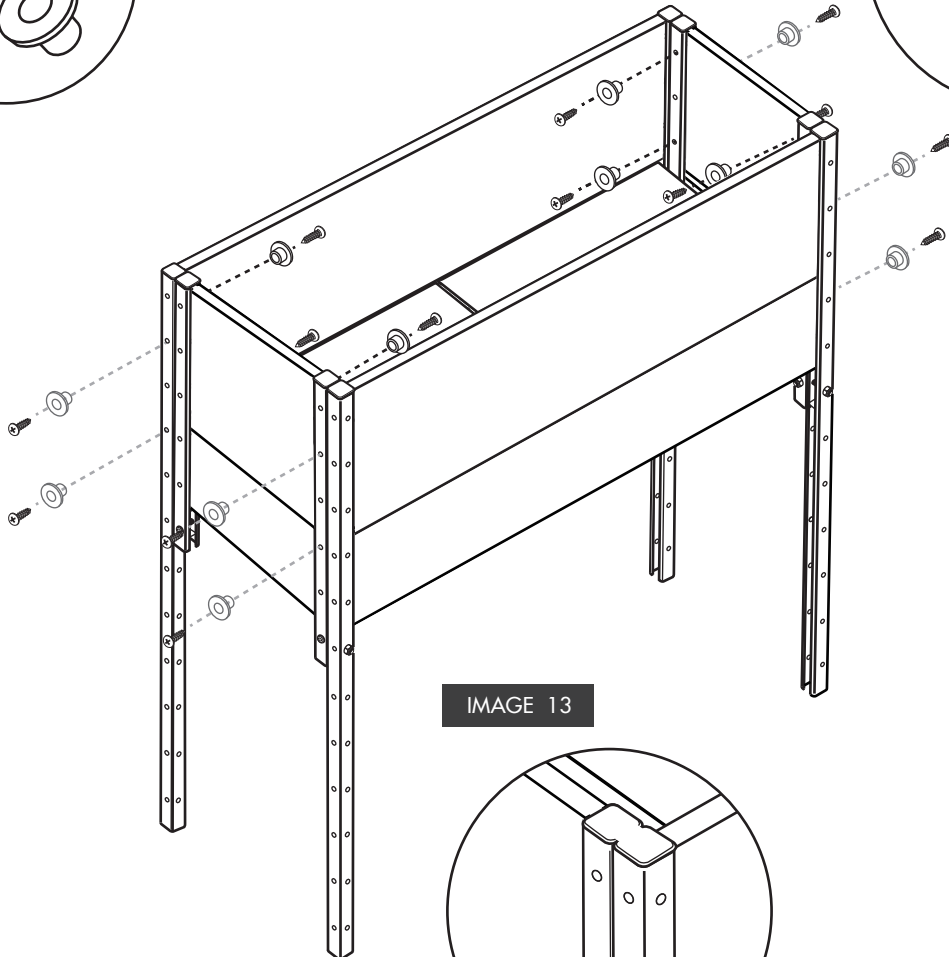
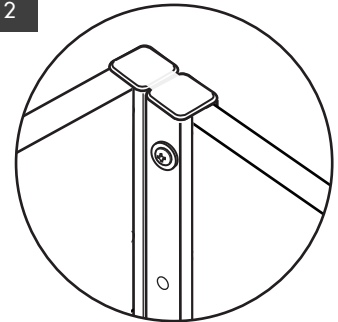
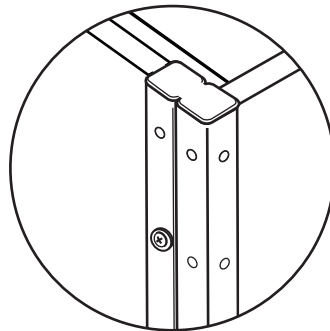

IMAGE 13



Assembly

Elevated Trough Planter Box - 36" L x 12" W x 28" H

Unfold the liner and cover the bottom of the garden bed, as shown in Image 14 and Image 15.

IMAGE 11

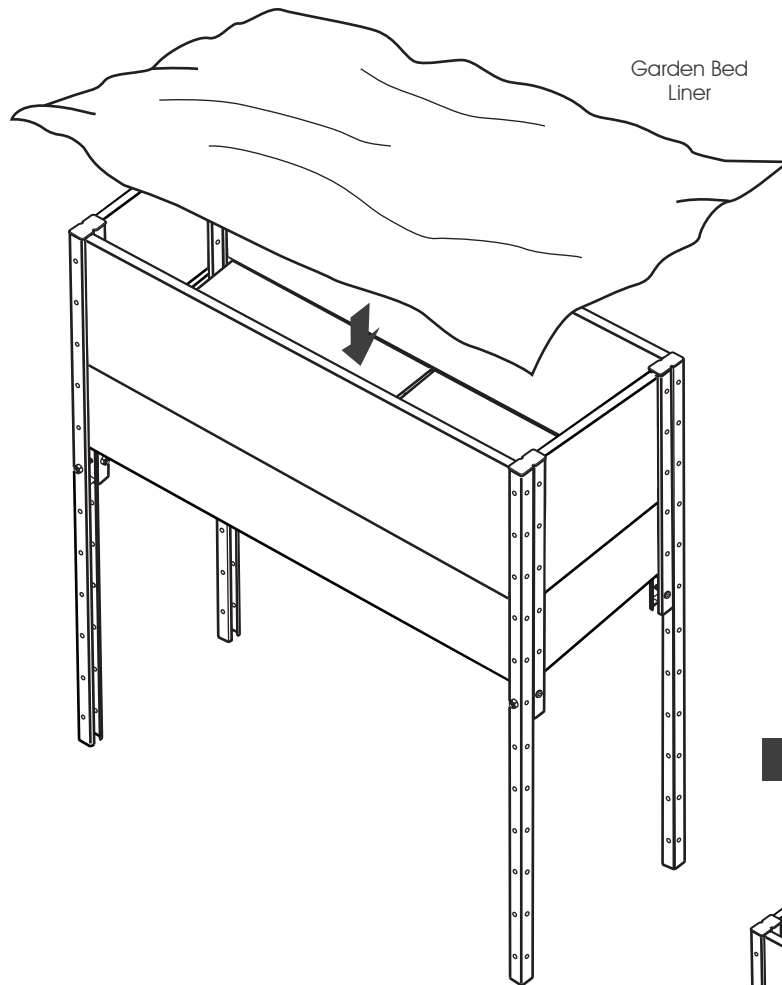
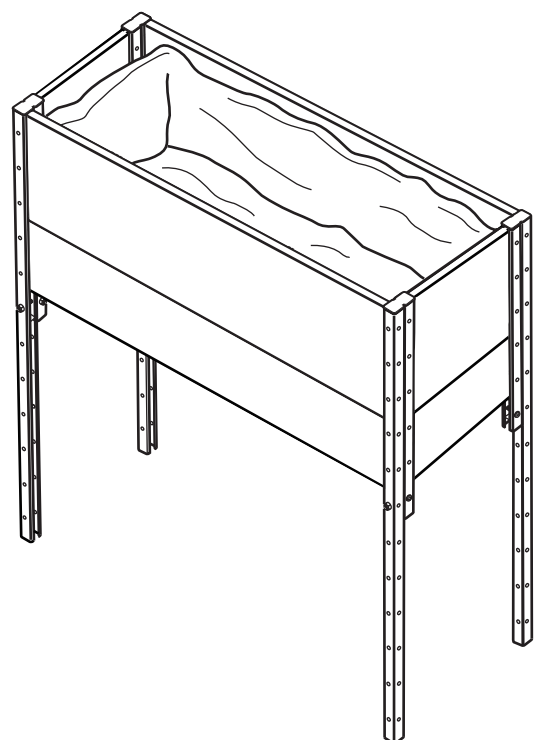

IMAGE 14



Note

Elevated Trough Planter Box - 36" L x 12" W x 28" H

Sometimes there might be a misalignment of the Corner Posts as shown in Image 16 and Image 17, which may result in difficulty of sliding boards into the brackets. Please adjust them to the right position so that they are parallel to each other, and perpendicular to the ground.

IMAGE 16

Assembling Problem 1

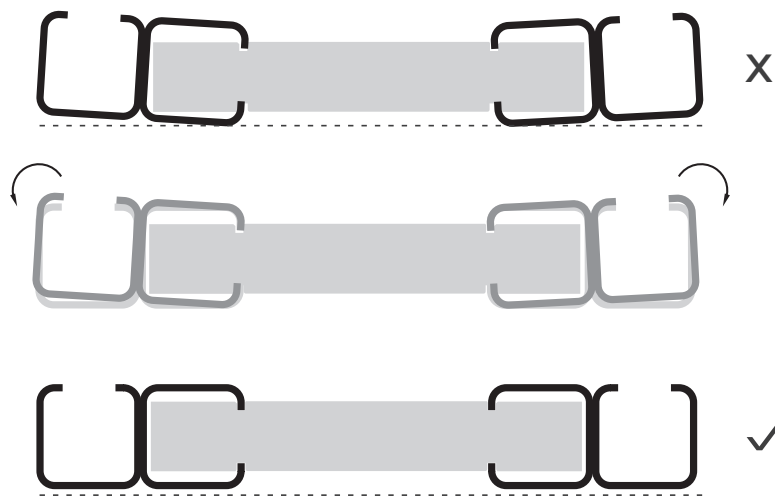
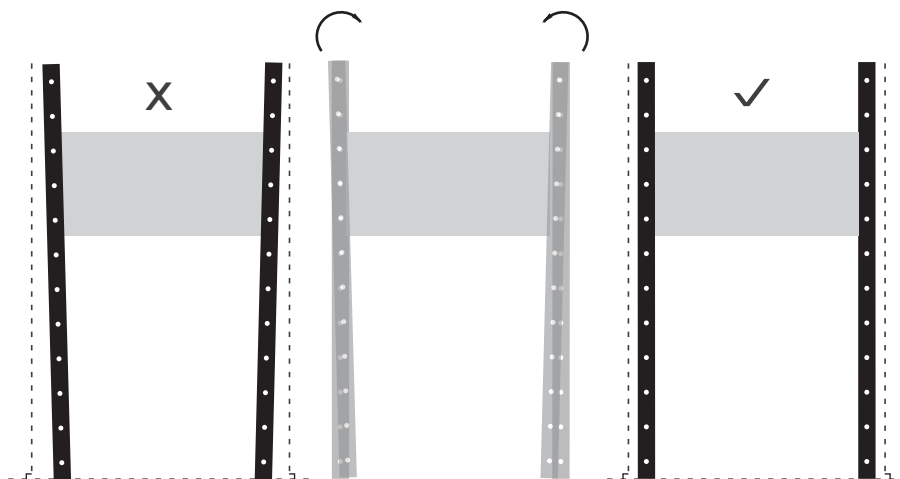

IMAGE 17

Assembling Problem 2



Bloom On.

Everbloom-Garden.com

US Patent Pending

★ Subscribe at www.everbloom-garden.com for
extra savings and upgrading information!

Distributed by:
Dynaforge Trading LLC
St. Paul, MN55101
Email: service@everbloom-garden.com