

**CROSS BARS ROOF RACKS FOR  
2011-2020 TOYOTA SIENNA  
INSTRUCTION MANUAL**

**CROSS BARS ROOF RACKS FOR  
2011-2020 TOYOTA SIENNA  
INSTRUCTION MANUAL**



Front Crossbar

Rear Crossbar

Instructions

PIC 2-1

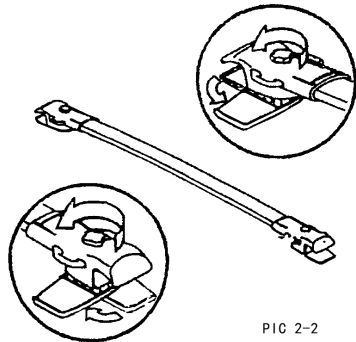

PIC 2-2

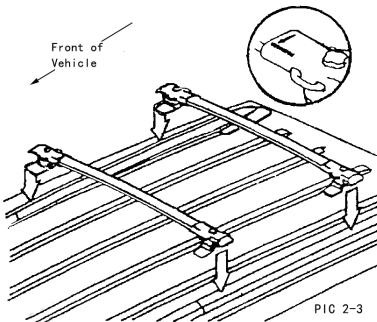

PIC 2-3

## 1. Vehicle Preparation.

- (a) Clean work area before installing cross bars.
  - Saturate a clean lint-free cloth with approved cleaner and clean the work surface of the vehicle.
  - Follow the solvent manufacturer's directions carefully. Do not allow cleaner to air dry.
  - Wipe the clean surface with a clean, dry, lint-free cloth.

## 2. Install Cross Bars

- (a) Remove cross bars and installations from packing.(PIC 2-1)
- (b) Loosen clamps by turning knobs counterclockwise.(PIC 2-2)
- (c) Rotate lower clamp 90°, so that the cross bars can be lowered between the roof rails.(PIC 2-2)

**NOTE: Front and Rear Cross Bars can be separated by labels. FORWARD arrow on clamp facing towards the front of vehicle.(PIC 2-3)**

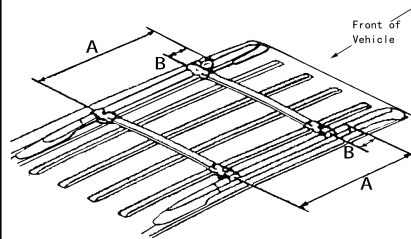

PIC 2-4

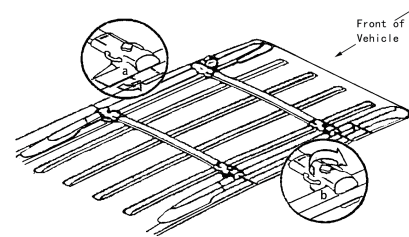

PIC 2-5

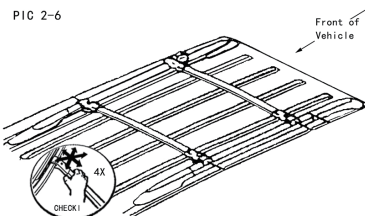

PIC 2-6

- (d) Position front and rear cross bars so that they are parallel A=820mm(32.25 inch), B=120mm(4.75 inch) from the end of the rails. (PIC 2-4)

- (e) Once in position, rotate lower clamps under side rails.(PIC 2-5a) Tighten clamps by turning knobs clockwise as much as possible until secure. (PIC 2-5b)

**NOTE: Ensure there is no gap between the end support and side rail on the vertical surface both left and right side.**

- (f) Finally, pulling the both Front and Rear Cross Bars any function in the strong hand to check if they are firmly. (PIC 2-6)