



ARROW SIDE BOARD

PART #: TB-C06

FITS:

- 2019-Up Chevy Silverado 1500 Double Cab (Exclude LD Model)
- 2020-Up Chevy Silverado 2500-3500 Double Cab
- 2019-Up GMC Sierra 1500 Double Cab (Exclude Limited Model)
- 2020-Up GMC Sierra 2500-3500 Double Cab



60-120 min



Cutting Not Required



Drilling Not Required

Torque & Tools

Fastener Size	Tightening Torque (ft-lbs)	Wrench Required		Allen Wrench Required	
			<input checked="" type="checkbox"/> 10mm		<input type="checkbox"/> 4mm
<input checked="" type="checkbox"/> 8mm	<input checked="" type="checkbox"/> 18-20		<input checked="" type="checkbox"/> 13mm		<input type="checkbox"/> 5mm
<input type="checkbox"/> 10mm	<input type="checkbox"/> 35-40		<input type="checkbox"/> 16mm		<input type="checkbox"/> 6mm
<input type="checkbox"/> 12mm	<input type="checkbox"/> 60-70		<input type="checkbox"/> 18mm		<input type="checkbox"/> 8mm

BEFORE INSTALLATION

REMOVE CONTENTS FROM BOX. VERIFY ALL PARTS ARE PRESENT. READ INSTRUCTIONS CAREFULLY BEFORE STARTING INSTALLATION. ASSISTANCE IS RECOMMENDED.

Part List

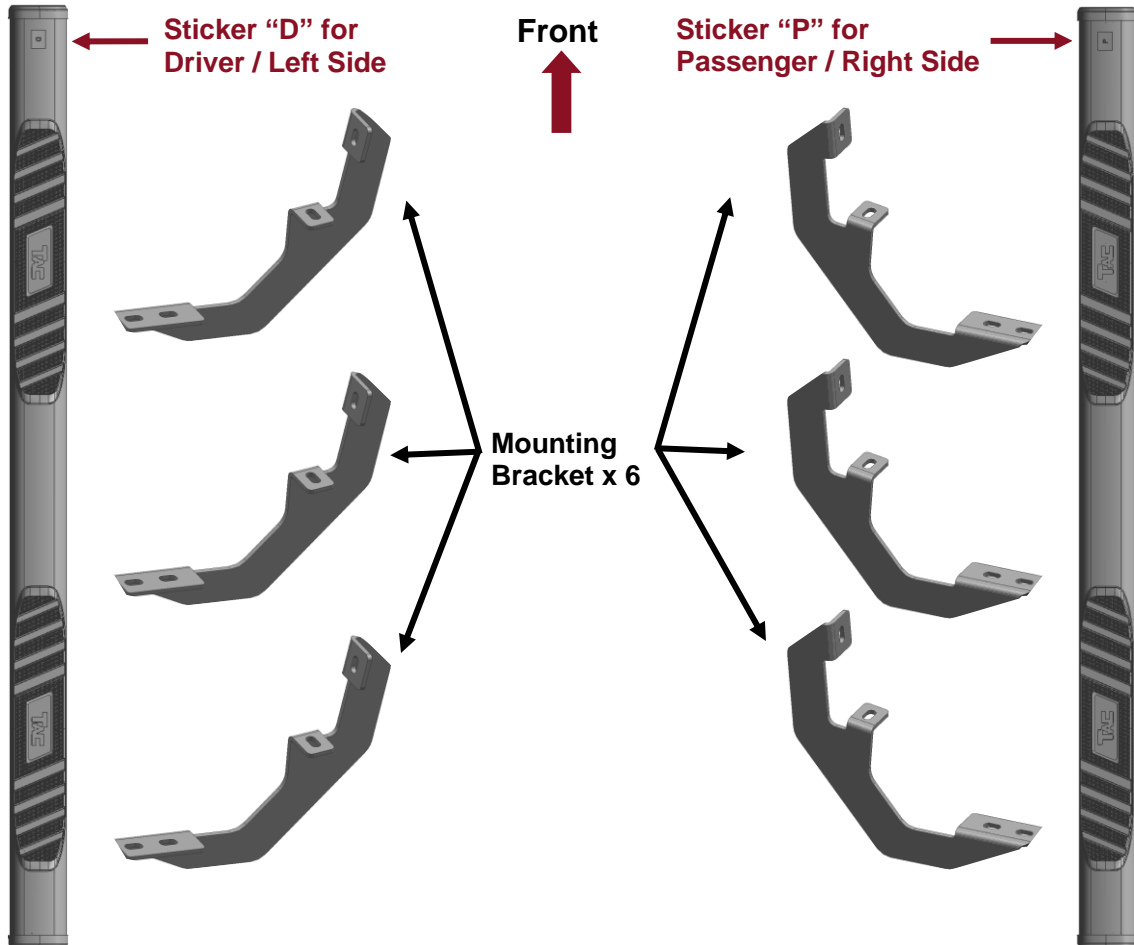

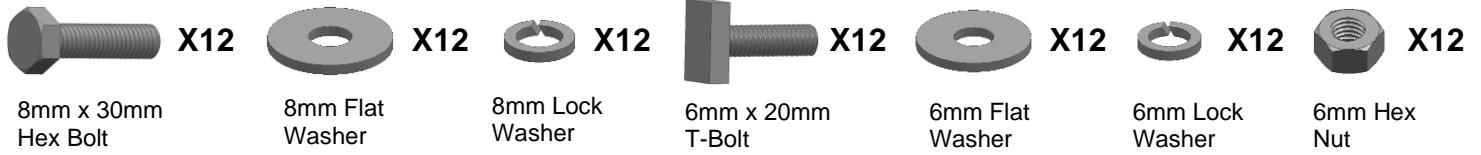

PLEASE NOTE THAT THE FOLLOWING PICTURES ARE BASED ON THE PASSENGER SIDE INSTALLATION

STEP 1

Start the installation under the Passenger/Right side of the vehicle. Locate the 6 plugs along the bottom edge of the body. Remove the plastic plugs from each mounting location, **(Fig 1)**.

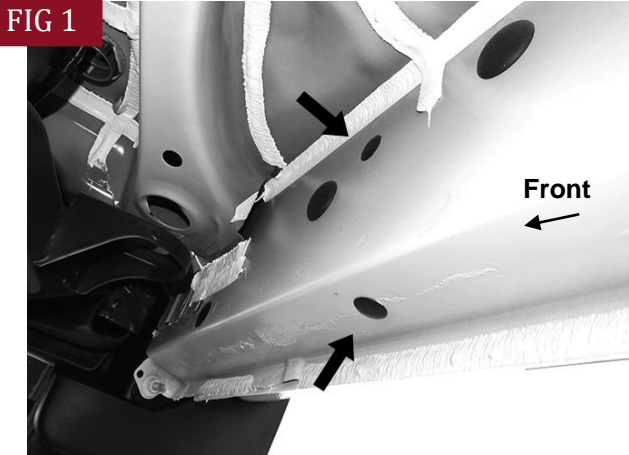

(Fig 1) Remove plastic plugs (arrows) to uncover threaded holes in floor

STEP 2

Mounting Brackets will attach to all threaded mounting holes, **(Fig 2)**. Directly above each threaded hole is a top mounting location on the side of the body panel. Hold a Bracket up in place to help determine the mounting holes to use along the body. **NOTE: Thread an 8mm Hex Bolt into the threaded holes to clear paint as required.**

FIG 2

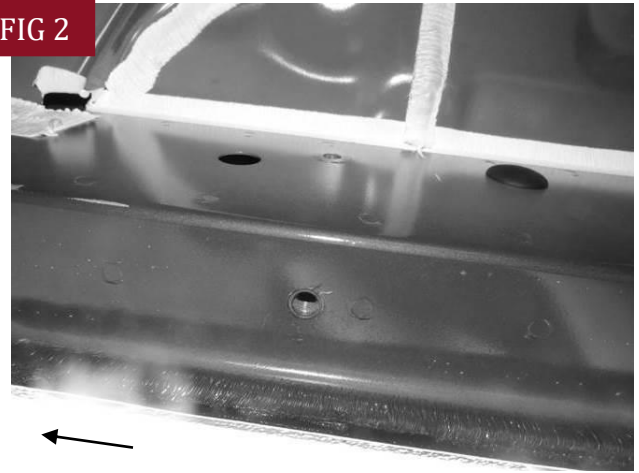

(Fig 2) Threaded holes (arrows) under the plastic plugs

STEP 3

Select (1) Passenger/Right Mounting Bracket. Attach the Mounting Bracket to the factory threaded holes with (2) 8mm Hex Bolts, (2) 8mm Lock Washers and (2) 8mm Flat Washers, **(Fig 3)**. Do not tighten hardware.

FIG 3

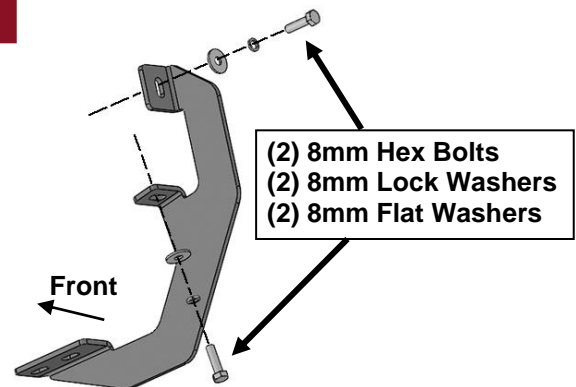

(Fig 3) Attach (1) Mounting Bracket to the Passenger/Right front location

STEP 4

Move along the body to the next mounting location. Repeat **Steps 1 - 3** to attach the remaining (2) Passenger/Right Mounting Bracket to the (2) remaining locations.

STEP 5

Select the Passenger/Right Side Step. **NOTE:** The Passenger/Right Side Step will have a **Sticker "P" on the front**. Insert (6) 6mm T-Bolts into the channels in the bottom of the Side Step, (**Figure 4**), (3 T-Bolts per channel). Attach the Side Step to the (3) Mounting Brackets with (6) 6mm Flat Washers, (6) 6mm Lock Washers and (6) 6mm Hex Nuts, (**Figure 5**). Do not tighten hardware.

FIG 4

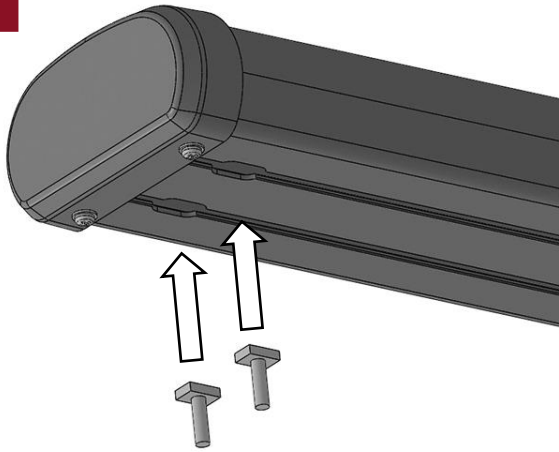

(Fig 4) Insert (6) 6mm T-Bolts into the channels in the bottom of the Side Step, (3 T-Bolts per channel)

FIG 5

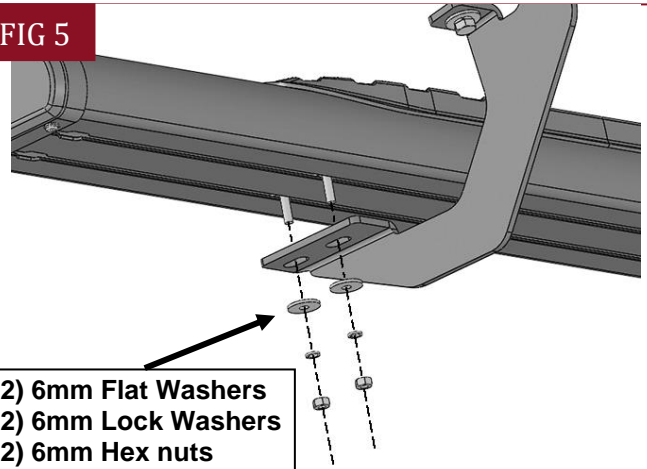

(Fig 5) Attach the Passenger/Right Side Step to the Mounting Brackets

STEP 6

Level and adjust the Side Step and tighten all hardware.

STEP 7

Repeat **Steps 1—6** to attach the Driver/Left Side Step.

STEP 8

Do periodic inspections to the installation to make sure that all hardware is secure and tight.

Attention

To protect your investment, do not use any type of polish or wax that may contain abrasives that could damage the finish.

Mild soap may be used also to clean the Side Steps.