



# SPEAR RUNNING BOARD

PART #: TAC-TA6-021

**FITS:** 2007-2021 Toyota Tundra Double Cab



60-120 min





Cutting Not Required



Drilling Not Required

## Torque & Tools

Fastener Size	Tightening Torque (ft-lbs)	Wrench Required	Allen Wrench Required	
				
<input checked="" type="checkbox"/> 6mm	<input checked="" type="checkbox"/> 7-8.5		<input checked="" type="checkbox"/> 10mm	<input type="checkbox"/> 4mm
<input checked="" type="checkbox"/> 8mm	<input checked="" type="checkbox"/> 18-20		<input checked="" type="checkbox"/> 13mm	<input type="checkbox"/> 5mm
<input type="checkbox"/> 10mm	<input type="checkbox"/> 35-40		<input type="checkbox"/> 16mm	<input type="checkbox"/> 6mm
<input type="checkbox"/> 12mm	<input type="checkbox"/> 60-70		<input type="checkbox"/> 18mm	<input type="checkbox"/> 8mm

## BEFORE INSTALLATION

REMOVE CONTENTS FROM BOX. VERIFY ALL PARTS ARE PRESENT. READ INSTRUCTIONS CAREFULLY BEFORE STARTING INSTALLATION. ASSISTANCE IS RECOMMENDED.

## Part List

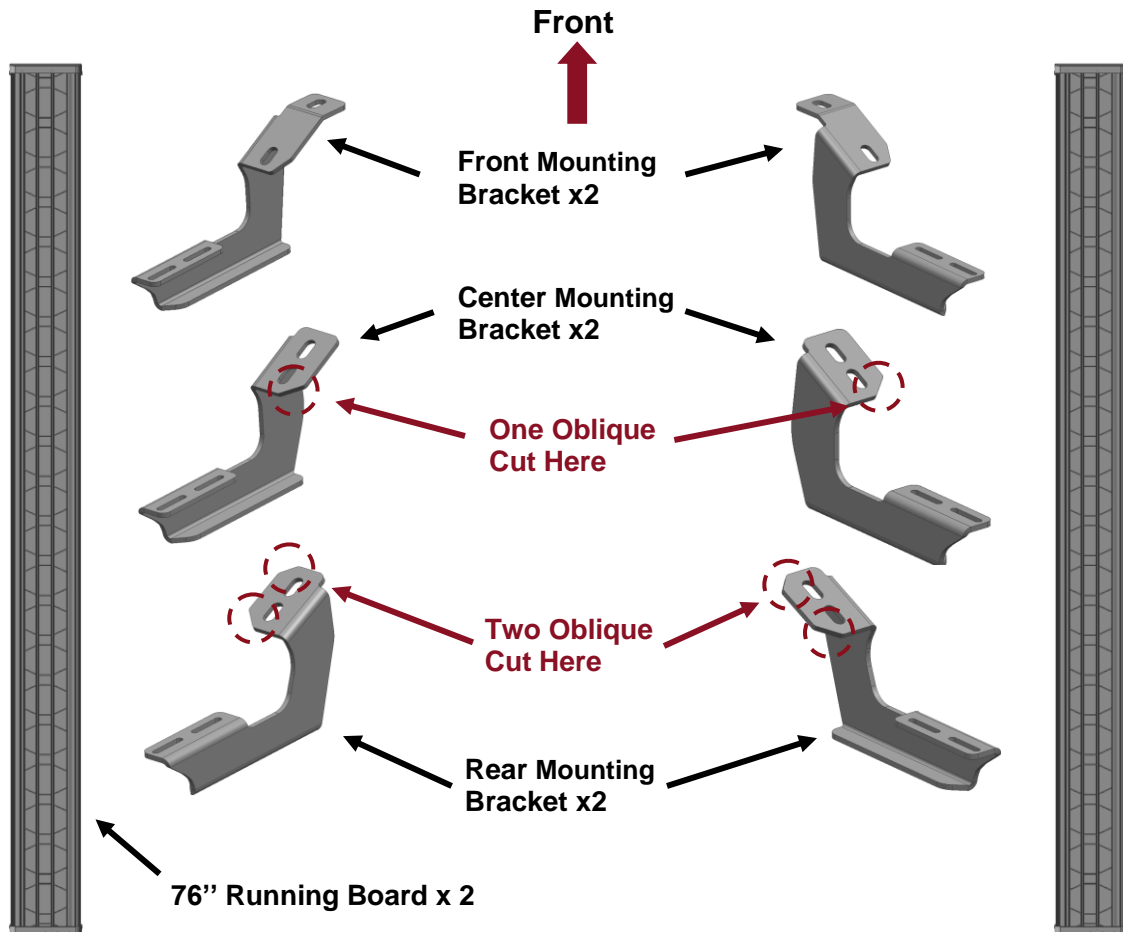

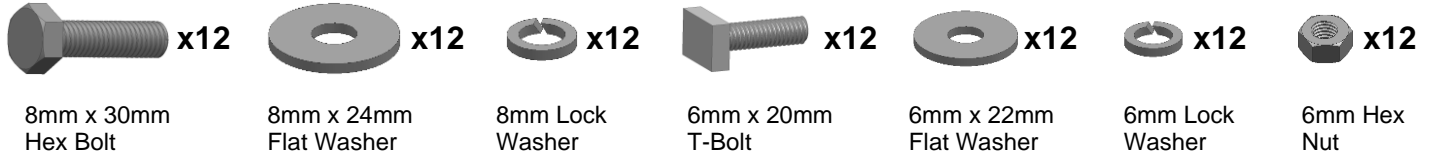

**PLEASE NOTE THAT THE FOLLOWING PICTURES ARE BASED ON THE DRIVER SIDE INSTALLATION**

## STEP 1

Starting on the Driver/Left front of the vehicle, remove the plastic plugs, (or hex bolts), covering the threaded holes in the body panel, **(Fig 1)**.

**FIG 1**

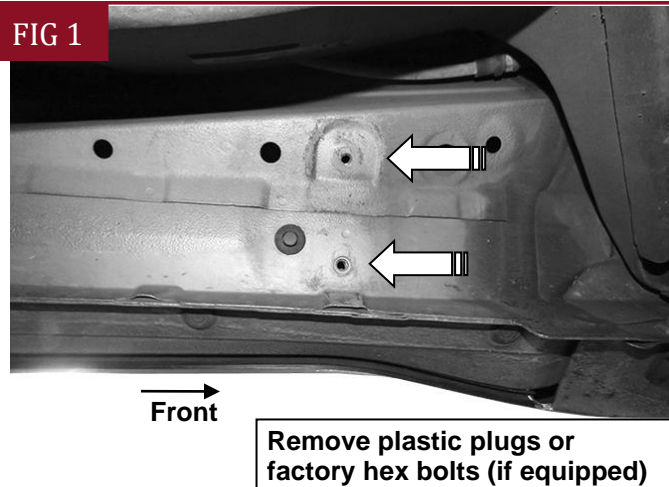

**(Fig 1) Driver/Left front mounting location**

## STEP 2

Select the (1) Front Mounting Bracket. Attach the Bracket to the vehicle with (2) 8mm Hex Bolts, (2) 8mm Lock Washers and (2) 8mm Flat Washers, **(Fig 2)**. Do not tighten hardware at this time.

**FIG 2**

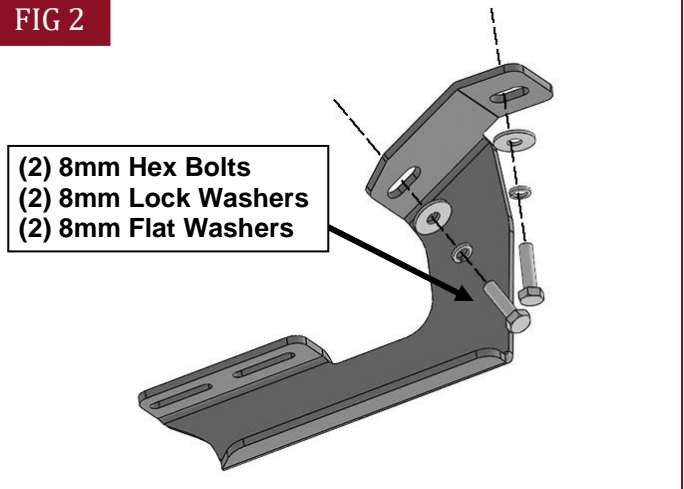

**(Fig 2) Attach (1) Front Mounting Bracket to the front mounting location**

## STEP 3

Move along the body panel to the center mounting location, **(Fig 3)**. Select (1) Center Mounting Bracket. Repeat **Step 2** to install the Mounting Bracket on center mounting location, **(Fig 4)**. Do not tighten hardware.

**FIG 3**

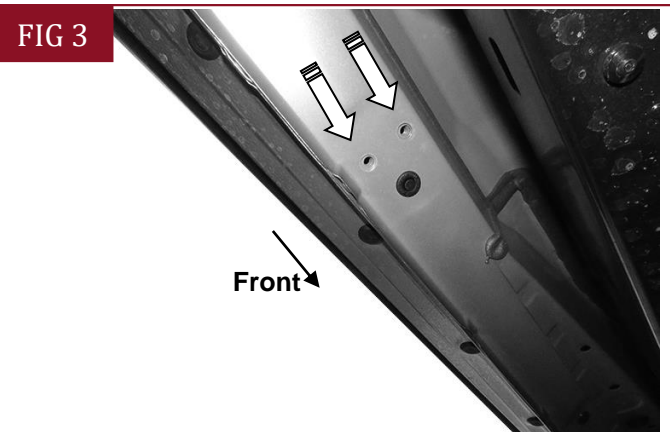

**(Fig 3) Driver/Left center mounting location**

FIG 4

- (2) 8mm Hex Bolts
- (2) 8mm Lock Washers
- (2) 8mm Flat Washers

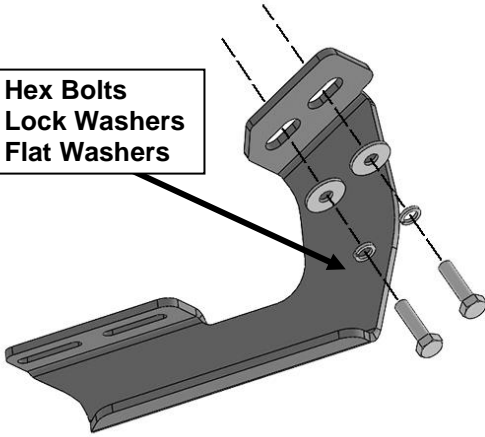

(Fig 4) Attach (1) Center Mounting Bracket to the center mounting locations

## STEP 4

Move along the body panel to the rear mounting location, (Fig 5). Select (1) Rear Mounting Bracket, Repeat **Step 2** to install the Mounting Bracket on rear mounting location, (Fig 4). Do not tighten hardware.

FIG 5

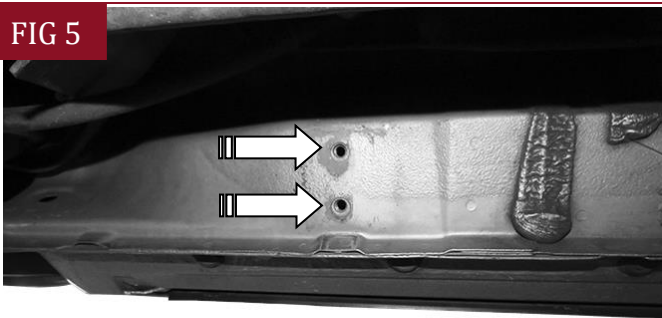

Rear

(Fig 5) Driver/Left rear mounting location

## STEP 5

Select (1) Running Board. Insert (6) 6mm T-Bolts into the channels in the bottom of the Running Board, (Fig 6), (3 T-Bolts per channel). Attach the Running Board to the (3) Mounting Brackets with (6) 6mm Flat Washers, (6) 6mm Lock Washers and (6) 6mm Hex Nuts, (Fig 7). Do not tighten hardware.

FIG 6

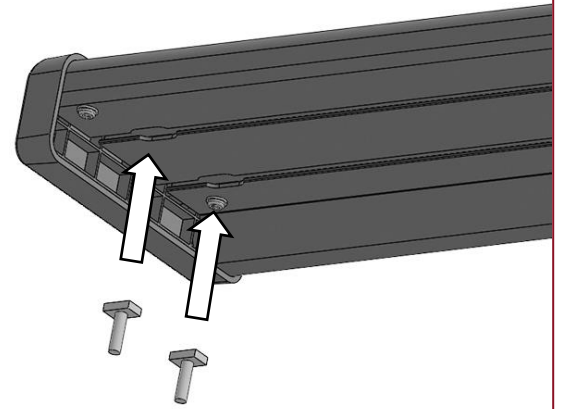

(Fig 6) Insert (6) 6mm T-Bolts into the channels in the bottom of the Running Board, (3 T-Bolts per channel)

FIG 7

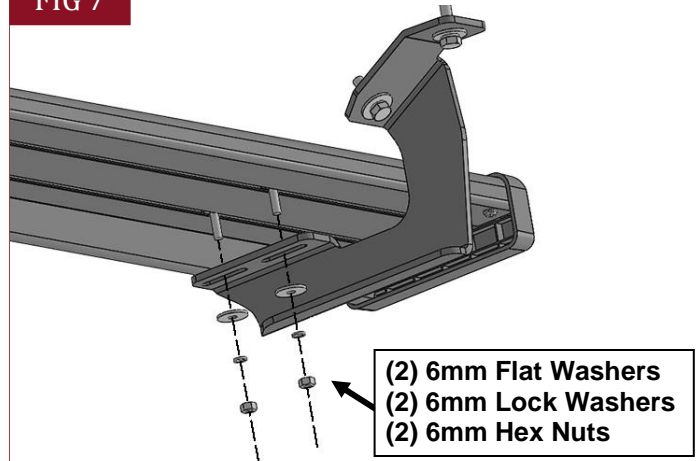

- (2) 6mm Flat Washers
- (2) 6mm Lock Washers
- (2) 6mm Hex Nuts

(Fig 7) Attach the Running Board to the Mounting Brackets

## STEP 6

Level and adjust the Running Board and fully tighten all hardware.

## STEP 7

Repeat **Steps 1—6** to attach the other side Running Board.

## STEP 8

Do periodic inspections to the installation to make sure that all hardware is secure and tight.

### Attention

To protect your investment, do not use any type of polish or wax that may contain abrasives that could damage the finish.

Mild soap may be used also to clean the Running Boards.