



SPEAR RUNNING BOARD

PART #: TAC-FA6-016

FITS: 2019-Up Ford Ranger Super Cab



60-120 min



Cutting Not Required



Drilling Not Required

Torque & Tools

Fastener Size	Tightening Torque (ft-lbs)	Wrench Required	Allen Wrench Included
<input checked="" type="checkbox"/> 6mm	<input checked="" type="checkbox"/> 7-8.5		
<input type="checkbox"/> 8mm	<input type="checkbox"/> 18-20		
<input checked="" type="checkbox"/> 10mm	<input checked="" type="checkbox"/> 35-40		
<input type="checkbox"/> 12mm	<input type="checkbox"/> 60-70		
		<input checked="" type="checkbox"/> 10mm	<input type="checkbox"/> 4mm
		<input type="checkbox"/> 13mm	<input type="checkbox"/> 5mm
		<input checked="" type="checkbox"/> 16mm	<input type="checkbox"/> 6mm
		<input type="checkbox"/> 18mm	<input type="checkbox"/> 8mm

BEFORE INSTALLATION

REMOVE CONTENTS FROM BOX. VERIFY ALL PARTS ARE PRESENT. READ INSTRUCTIONS CAREFULLY BEFORE STARTING INSTALLATION. ASSISTANCE IS RECOMMENDED.

Part List

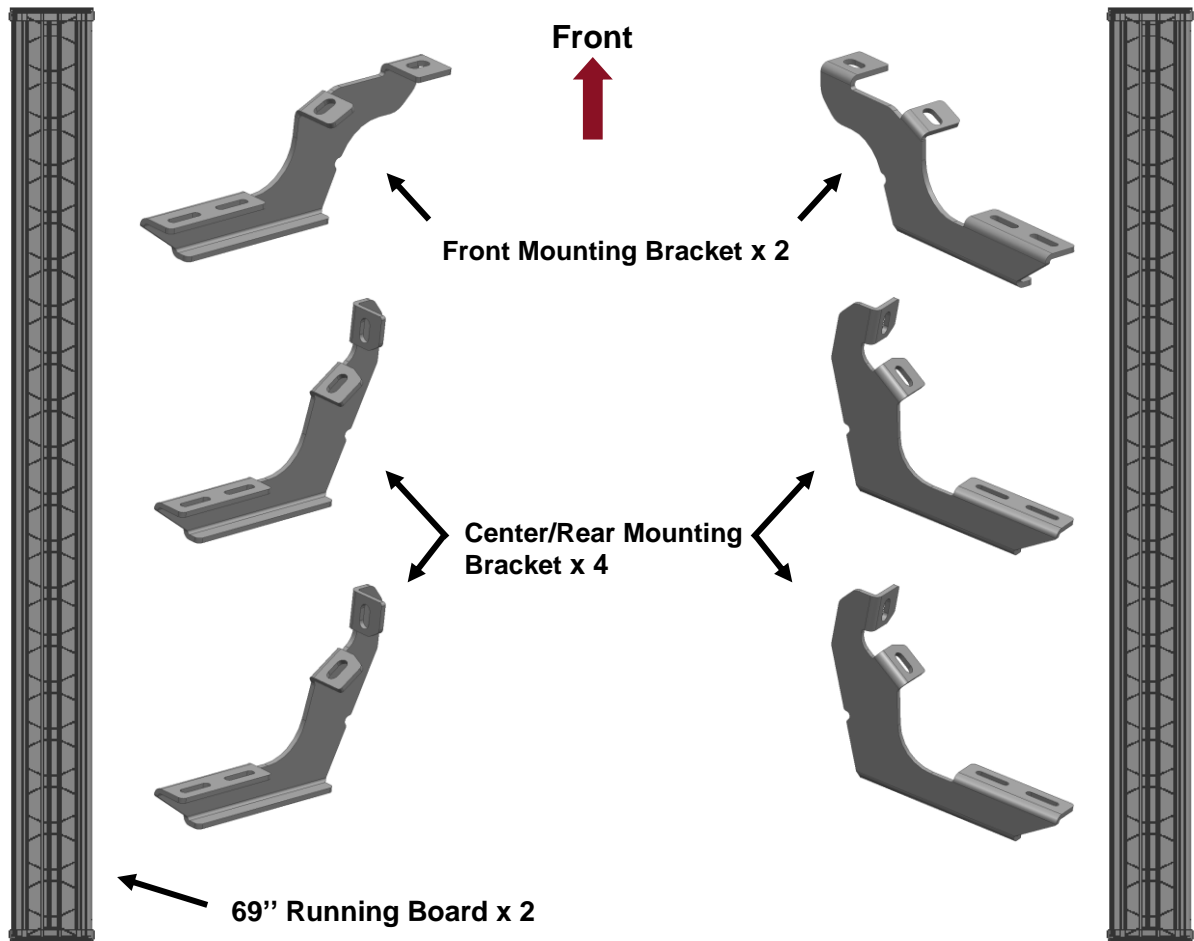

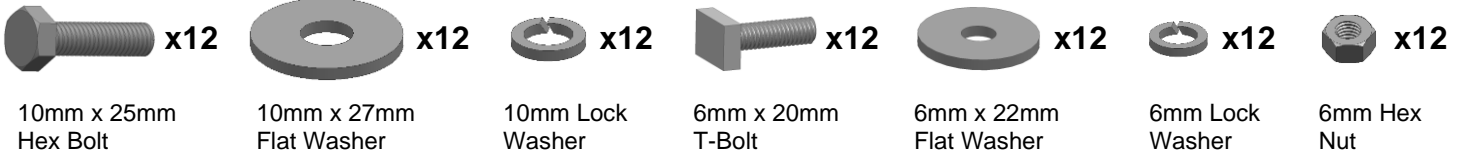

PLEASE NOTE THAT THE FOLLOWING PICTURES ARE BASED ON THE PASSENGER SIDE INSTALLATION

STEP 1

Start the installation on the Passenger/Right side of the vehicle. Locate the front factory mounting location along the inner side of the body, **(Fig 1)**. Remove the plastic plugs covering the holes.

FIG 1

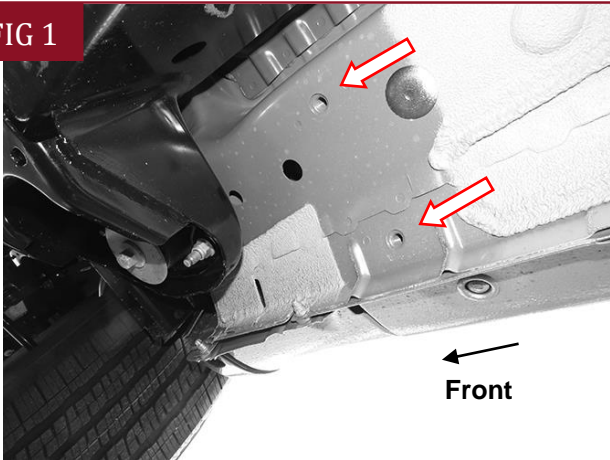

(Fig 1) Passenger/Right Front mounting location.

STEP 2

Select (1) Front Mounting Bracket, **(Fig 2)**. Attach to Passenger/Right front mounting location with (2) 10mm x 25mm Hex Bolts, (2) 10mm Lock Washers and (2) 10mm Flat Washers **(Fig 1 & 2)**. Do not tighten hardware.

FIG 2

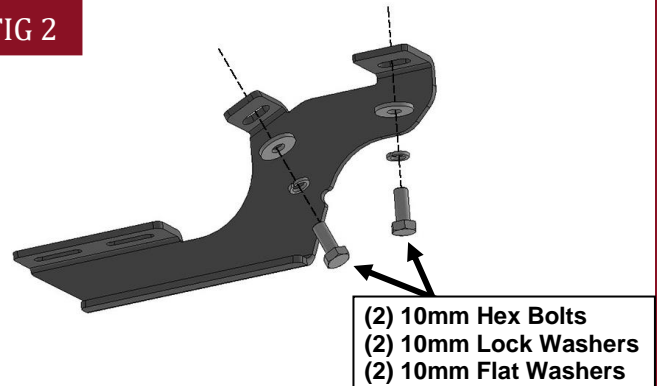

(Fig 2) Attach (1) Front Mounting Bracket to the front location

STEP 3

Repeat **Steps 1 - 2** to attach (2) Passenger/Right Center/Rear Mounting Brackets to the center and rear locations, **(Figs 3 - 5)**. Do not tighten hardware.

FIG 3

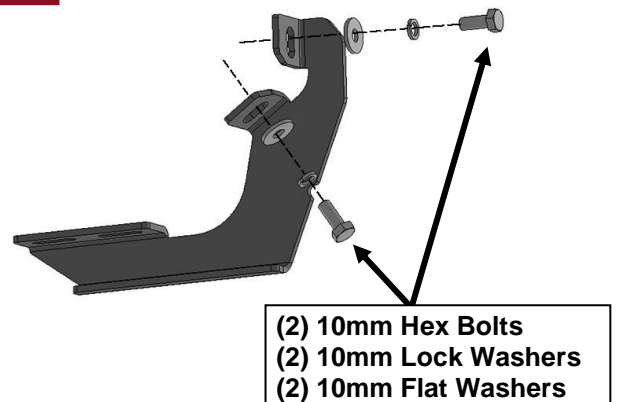

(Fig 3) Attach (1) Center/Rear Mounting Bracket to the center and rear locations

FIG 4

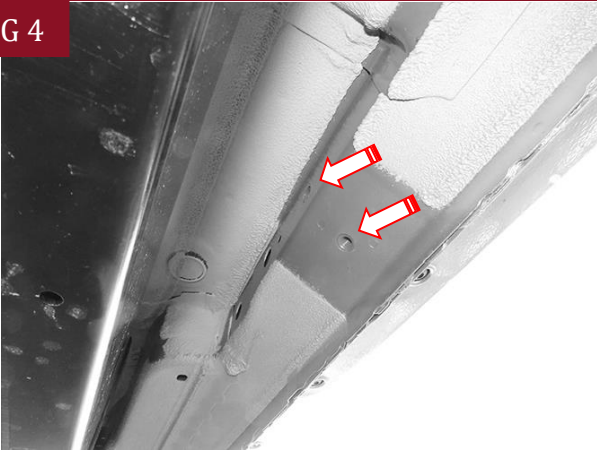

(Fig 4) Passenger/Right Center mounting location

FIG 5

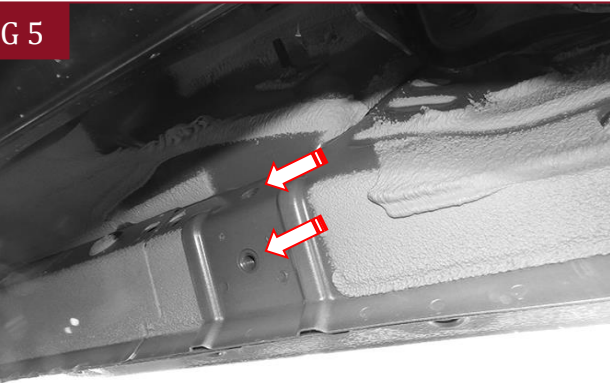

(Fig 5) Passenger/Right near mounting location

STEP 5

Select (1) Running Board. Insert (6) 6mm T-Bolts into the channels in the bottom of the Running Board, (Fig 6), (3 T-Bolts per channel). Attach the Running Board to the (3) Mounting Brackets with (6) 6mm Flat Washers, (6) 6mm Lock Washers and (6) 6mm Hex Nuts, (Fig 7). Do not tighten hardware.

FIG 6

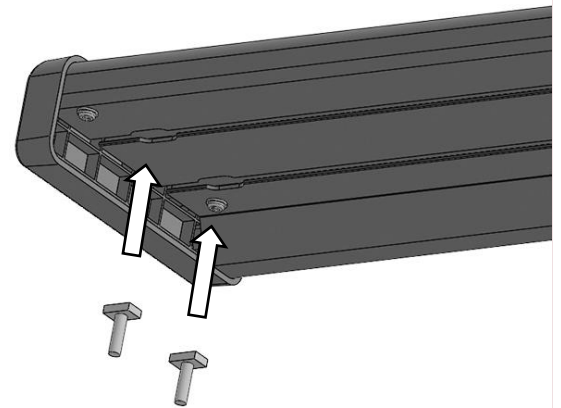

(Fig 6) Insert (6) 6mm T-Bolts into the channels in the bottom of the Running Board, (3 T-Bolts per channel)

FIG 7

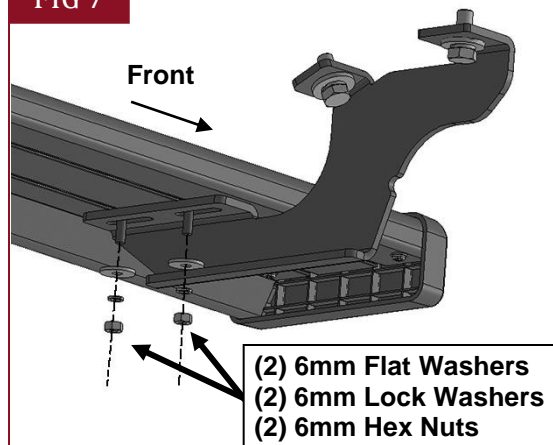

(Fig 7) Attach a Running Board to the Mounting Brackets

STEP 6

Level and adjust the Running Board as necessary and fully tighten all hardware.

STEP 7

Repeat **Steps 1—6** for the other side Running Board installation.

STEP 8

Do periodic inspections to the installation to make sure that all hardware is secure and tight.

Attention

To protect your investment, do not use any type of polish or wax that may contain abrasives that could damage the finish.

Mild soap may be used also to clean the Running Boards.