



SPEAR RUNNING BOARD

PART #: TAC-FA6-013

FITS:

- 2015-Up Ford F150 SuperCrew Cab
- 2022-Up Ford F150 Lightning EV SuperCrew Cab
- 2017-Up Ford F250/F350/F450/F550 Super Duty Crew Cab



60-120 min



Cutting Not Required



Drilling Not Required

Torque & Tools

Fastener Size	Tightening Torque (ft-lbs)	Wrench Required		Allen Wrench Required	
			<input checked="" type="checkbox"/> 10mm		<input type="checkbox"/> 4mm
<input checked="" type="checkbox"/> 6mm	<input checked="" type="checkbox"/> 7-8.5		<input checked="" type="checkbox"/> 13mm		<input type="checkbox"/> 5mm
<input checked="" type="checkbox"/> 8mm	<input checked="" type="checkbox"/> 18-20		<input type="checkbox"/> 16mm		<input type="checkbox"/> 6mm
<input type="checkbox"/> 10mm	<input type="checkbox"/> 35-40		<input type="checkbox"/> 18mm		<input type="checkbox"/> 8mm
<input type="checkbox"/> 12mm	<input type="checkbox"/> 60-70				

BEFORE INSTALLATION

REMOVE CONTENTS FROM BOX. VERIFY ALL PARTS ARE PRESENT. READ INSTRUCTIONS CAREFULLY BEFORE STARTING INSTALLATION. ASSISTANCE IS RECOMMENDED.

Part List

85" Running Board x 2

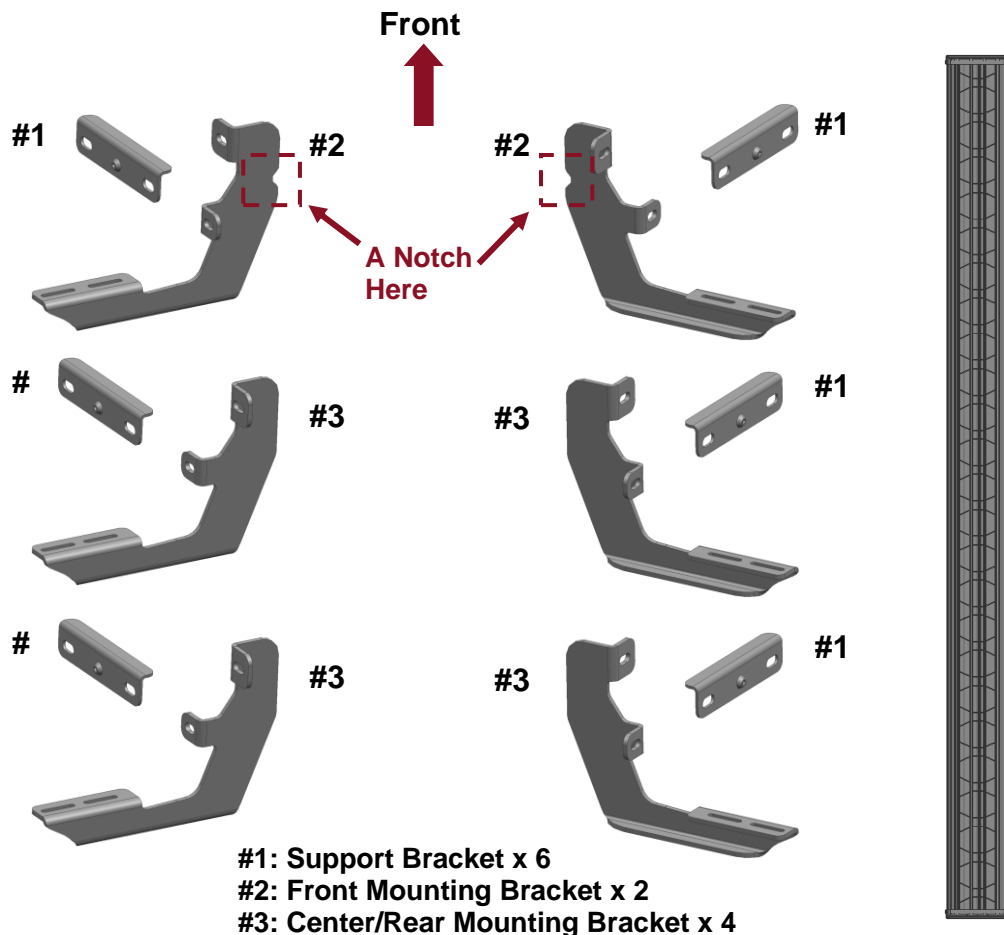

- #1: Support Bracket x 6
- #2: Front Mounting Bracket x 2
- #3: Center/Rear Mounting Bracket x 4

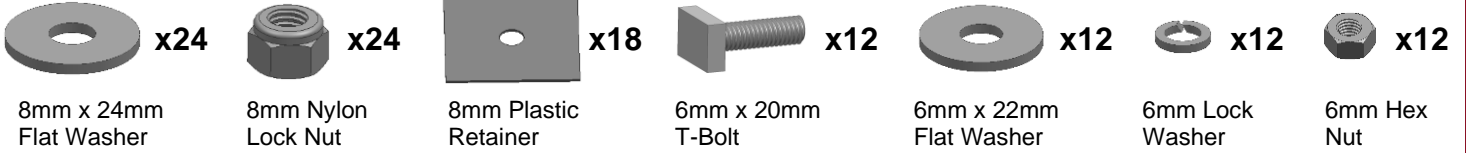

PLEASE NOTE THAT THE FOLLOWING PICTURES ARE BASED ON THE DRIVER SIDE INSTALLATION

STEP 1

Start the installation under the Driver/Left side of the vehicle. Locate the front (3) factory studs along the inner side of the body panel, **(Fig 1)**. Use a wire brush or thread chaser die to remove excess paint and/or undercoating from all studs.

FIG 1

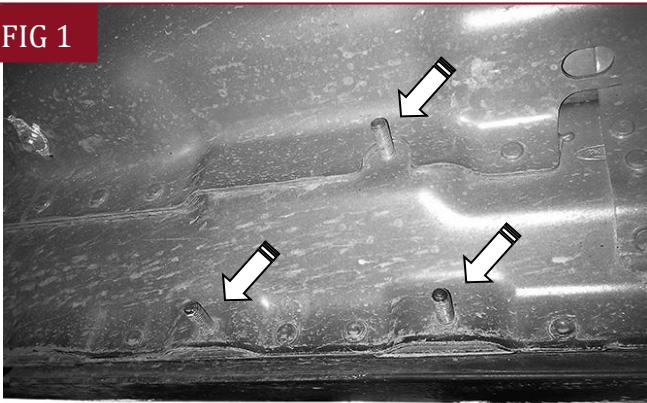

(Fig 1) Example of typical mounting location

STEP 2

Slide (1) Plastic Washer over each of the (3) factory mounting studs in the body panel, **(Fig 2)**. **IMPORTANT:** The Plastic Washers are designed to prevent corrosion between the aluminum body panel and the steel mounting brackets. **Do not install the Brackets without the Plastic Washers.**

FIG 2

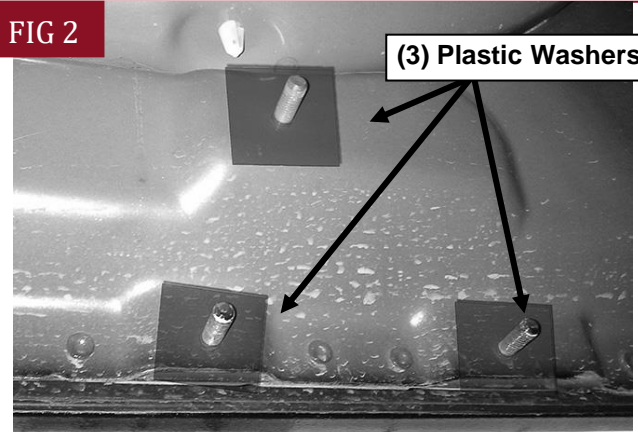

(Fig 2) Thread Plastic Washers onto all mounting studs

STEP 3

Select (1) Support Bracket (#1). Attach the Bracket to the studs with (2) 8mm Flat Washers and (2) 8mm Nylon Lock Nuts, **(Figs 3 - 4)**. Do not tighten hardware.

FIG 3

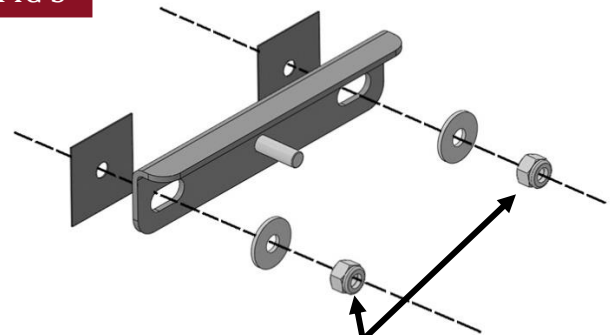

(2) 8mm Plastic Washers
(2) 8mm Flat Washers
(2) 8mm Nylon Lock Nuts

(Fig 3) Attach (1) Support Bracket (#1) to the threaded studs

FIG 4



(Fig 4) Example of the Support Bracket (#1) attached to the threaded studs

FIG 6

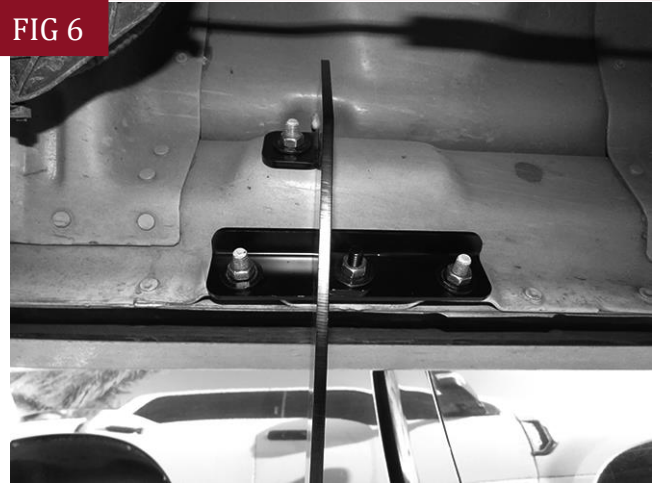

(Fig 6) Example of the Mounting Bracket attached to the upper mounting stud and Support Bracket

STEP 4

Then attach (1) Front Mounting Bracket (#2) to the upper factory mounting stud and support bracket with (1) Plastic Retainer, (2) 8mm Flat Washers, and (2) 8mm Nylon Lock Nuts, (Figs 5-6). **Note:** There is a notch on the back of the Front bracket.

FIG 5

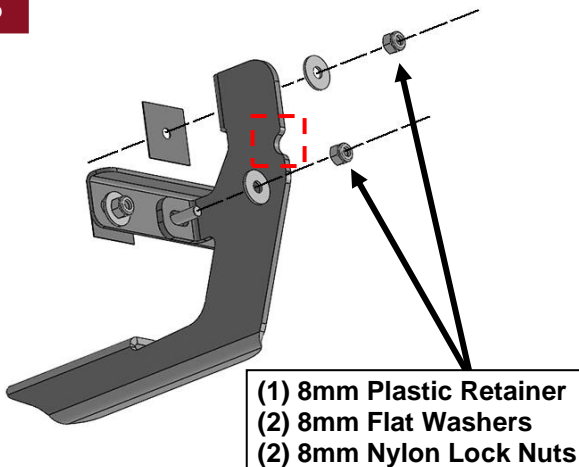

(Fig 5) Attach Front Mounting Bracket (#2) to the upper mounting stud and Support Bracket (#1)

STEP 5

Repeat **Step 3 - 4** to attach the remaining (2) Support Mounting Brackets (#1) and (2) Center/Rear Mounting Brackets (#3) to the center and rear mounting locations along the body panel, (Figs 7-8).

FIG 7



(Fig 7) Driver/Left Center mounting location

FIG 8

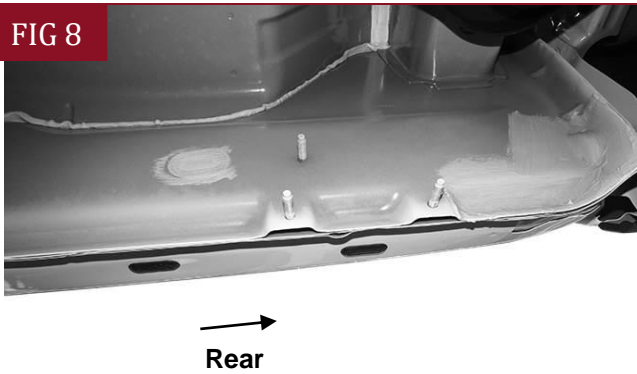

(Fig 8) Driver/Left Rear mounting location

FIG 10

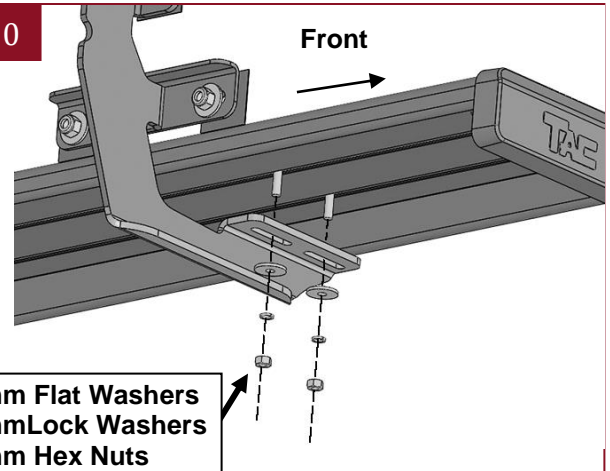

(Fig 10) Attach (1) Running Board to the (3) Mounting Brackets

STEP 6

Select (1) Running Board. Insert (6) 6mm T-Bolts into the channels in the bottom of the Running Board, (Fig 9), (3 T-Bolts per channel). Attach the Running Board to the (3) Mounting Brackets with (6) 6mm Flat Washers, (6) 6mm Lock Washers and (6) 6mm Hex Nuts, (Fig 10). Do not tighten hardware.

FIG 9

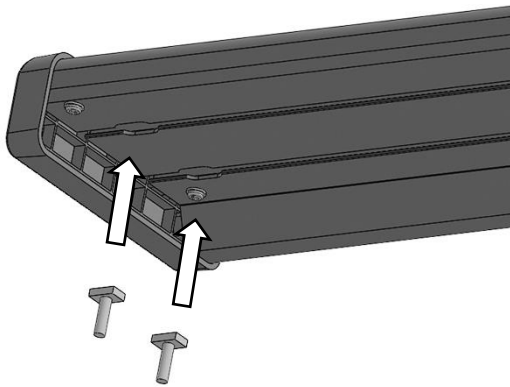

(Fig 9) Insert (6) 6mm T-Bolts into the channels in the bottom of the Running Board, (3 T-Bolts per channel)

STEP 7

Level and adjust the Running Board as necessary and fully tighten all hardware.

STEP 8

Repeat **Steps 1—7** to attach the other side Running Board to the vehicle.

STEP 9

Do periodic inspections to the installation to make sure that all hardware is secure and tight.

Attention

To protect your investment, do not use any type of polish or wax that may contain abrasives that could damage the finish.

Mild soap may be used also to clean the Running Boards.