



SPEAR RUNNING BOARD

PART #: TAC-CA6-004

FITS:

- 2007-2018 Chevy Silverado 1500 Regular Cab
- 2007-2019 Chevy Silverado 2500/3500 Regular Cab
- 2007-2018 GMC Sierra 1500 Regular Cab
- 2007-2019 GMC Sierra 2500/3500 Regular Cab



60-120 min



Cutting May Required



Drilling Not Required

Torque & Tools

Fastener Size	Tightening Torque (ft-lbs)	Wrench Required		Allen Wrench Required	
			<input checked="" type="checkbox"/> 10mm		<input type="checkbox"/> 4mm
<input checked="" type="checkbox"/> 6mm	<input checked="" type="checkbox"/> 7-8.5		<input checked="" type="checkbox"/> 13mm		<input type="checkbox"/> 5mm
<input checked="" type="checkbox"/> 8mm	<input checked="" type="checkbox"/> 18-20		<input type="checkbox"/> 16mm		<input type="checkbox"/> 6mm
<input type="checkbox"/> 10mm	<input type="checkbox"/> 35-40		<input type="checkbox"/> 18mm		<input type="checkbox"/> 8mm
<input type="checkbox"/> 12mm	<input type="checkbox"/> 60-70				

BEFORE INSTALLATION

REMOVE CONTENTS FROM BOX. VERIFY ALL PARTS ARE PRESENT. READ INSTRUCTIONS CAREFULLY BEFORE STARTING INSTALLATION. ASSISTANCE IS RECOMMENDED.

Part List

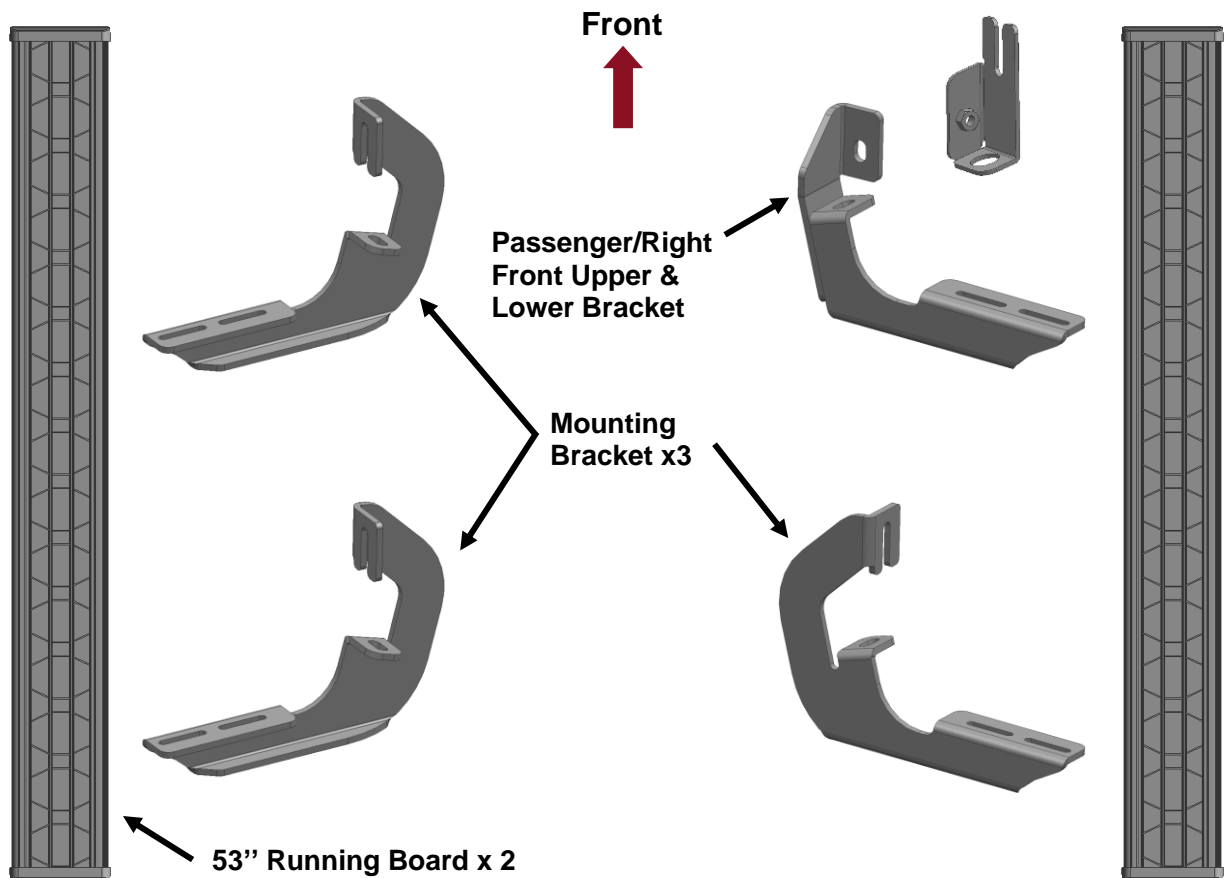



8mm x 35mm
Bolt Plate



8mm x 25mm
Hex Bolt



8mm x 24mm
Flat Washer



8mm Lock
Washer

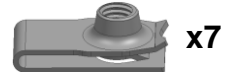

8mm Clip
Nut

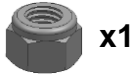

8mm Nylon
Lock Nut



6mm x 20mm
T-Bolt

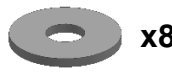

6mm x 22mm
Flat Washer



6mm Lock
Washer



6mm Hex
Nut

PLEASE NOTE THAT THE FOLLOWING PICTURES ARE BASED ON THE DRIVER SIDE INSTALLATION

STEP 1

Start the installation under the Driver/Left side of the vehicle. Locate the 2 tabs along the bottom edge of the body pinch weld. **(Fig 1)**. Directly above each tab is a top mounting location on the side of the rocker panel. Hold a Bracket up in place to help determine the mounting holes to use along the body.

FIG 1

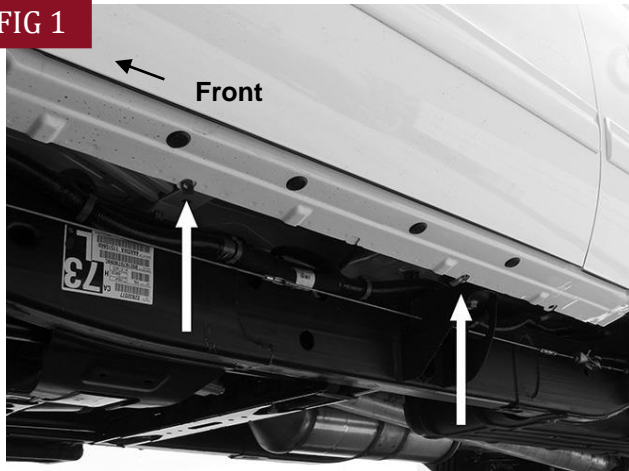

(Fig 1) Driver/Left (2) mounting locations

STEP 2

Determine the correct procedure for your model year and each Bracket location.

(1) Bottom mounting location (on the edge of the pinch weld).

a. Flat tab on pinch weld with factory installed weld nut:

Thread hex bolt into weld nut from the backside-down to clear paint from threads, **(Fig 2)**.

b. Flat tab on pinch weld with hole:

Select (1) 8mm Clip Nut. Slide the Clip Nut over the tab with the nut facing up behind the tab, **(Fig 3)**. Line up threaded nut with hole in the tab. Repeat for each mounting location.

(2) Top mounting location (on the back side of the rocker panel).

a. Models with factory installed threaded insert in rocker panel:

Thread 8mm Hex Bolt into threaded insert to clear paint as required, **(Figs 2 & 3)**.

b. Large and small hole in side of body panel:

Remove the rubber plug from the larger hole, **(Figs 4)**. Select (1) 8mm Clip Nut. Slide the Clip Nut into the larger hole. Line up the threaded nut with the smaller hole **(Figs 5)**.

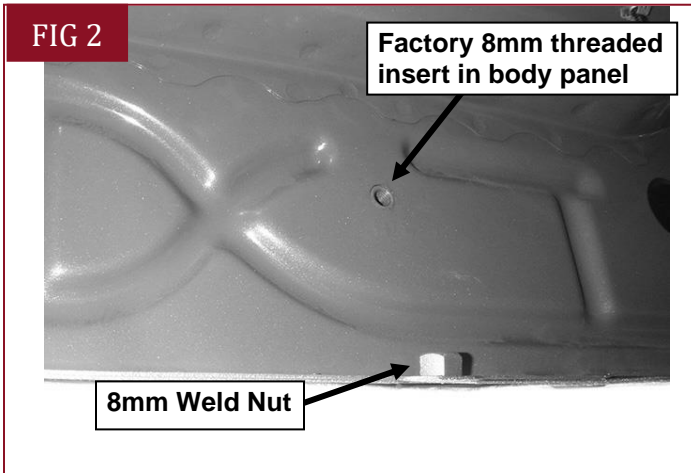

(Fig 2) Bottom mounting point with "Weld Nut". Top mounting point with "Threaded Insert".

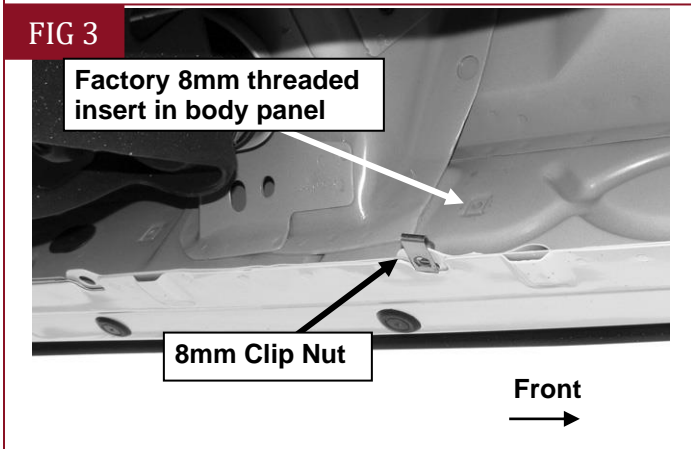

(Fig 3) Bottom mounting point with "Hole". Top mounting point with "Threaded Insert".

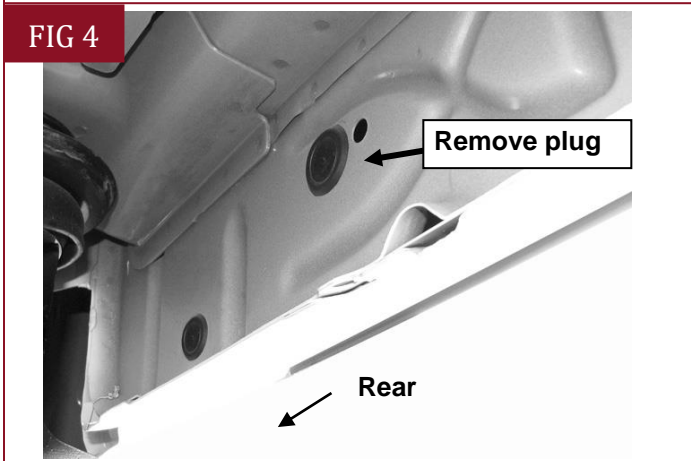

(Fig 4) Bottom mounting point with "Hole". Top mounting point with "Large and Small Hole".

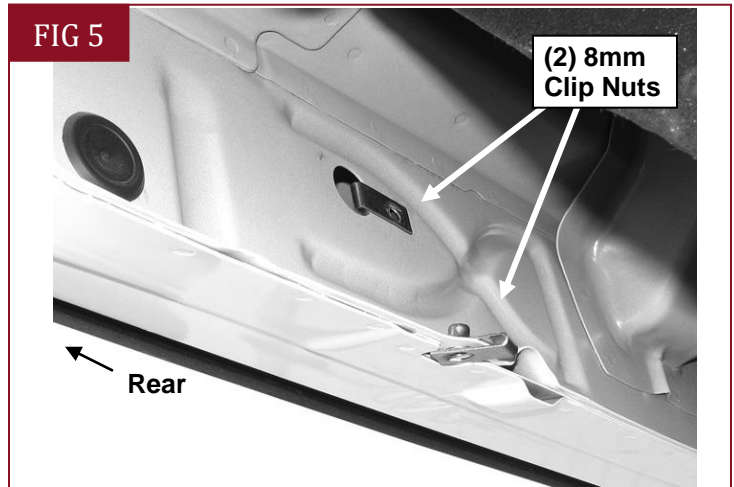

(Fig 5) Driver side rear mounting location with Clip Nuts installed.

STEP 3

Select (1) Mounting Bracket. Attach the Mounting Bracket to the Clip Nuts and/or the factory threaded holes with (2) 8mm Hex Bolts, (2) 8mm Lock Washers and (2) 8mm Flat Washers, (Figs 6-8). Do not tighten hardware.

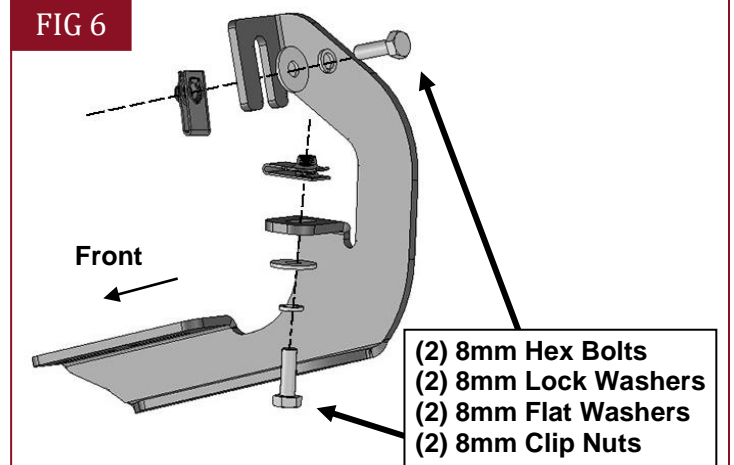

(Fig 6) Attach (1) Mounting Bracket to the Driver/Left mounting location

FIG 7



(Fig 7) Attach the Mounting Bracket to the factory threaded holes

FIG 8

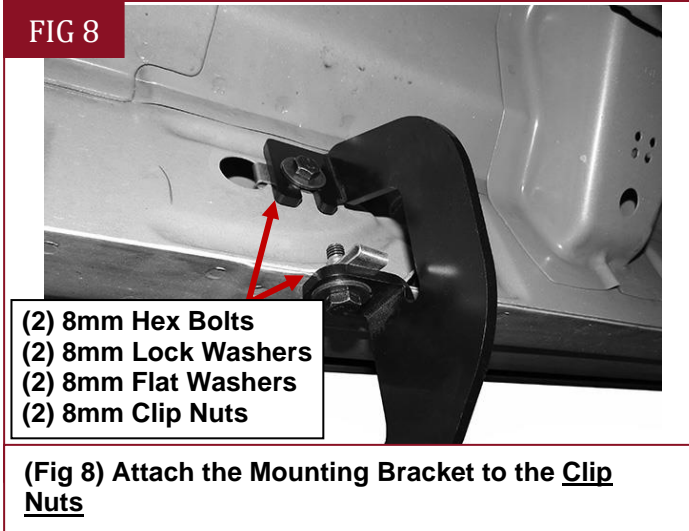

(Fig 8) Attach the Mounting Bracket to the Clip Nuts

STEP 4

Repeat **Steps 1—3** to attach (1) Mounting Brackets to the Driver/Left rear side.

STEP 5

Select the (1) Running Board. Insert (4) 6mm T-Bolts into the channels in the bottom of the Running Board, (**Fig 9**), (2 T-Bolts per channel). Attach the Running Board to the (2) Mounting Brackets with (4) 6mm Flat Washers, (4) 6mm Lock Washers and (4) 6mm Hex Nuts, (**Fig 10**). Do not tighten hardware.

FIG 9

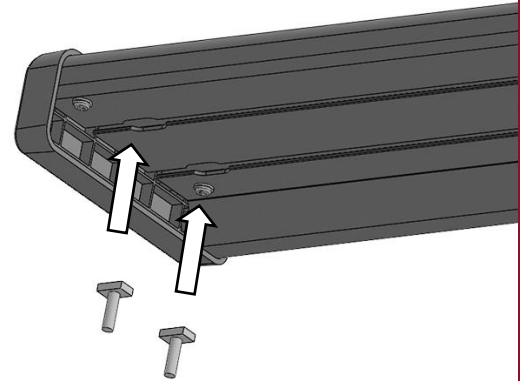

(Fig 9) Insert (4) 6mm T-Bolts into the channels in the bottom of the Running Board (2 T-Bolts per channel)

FIG 10

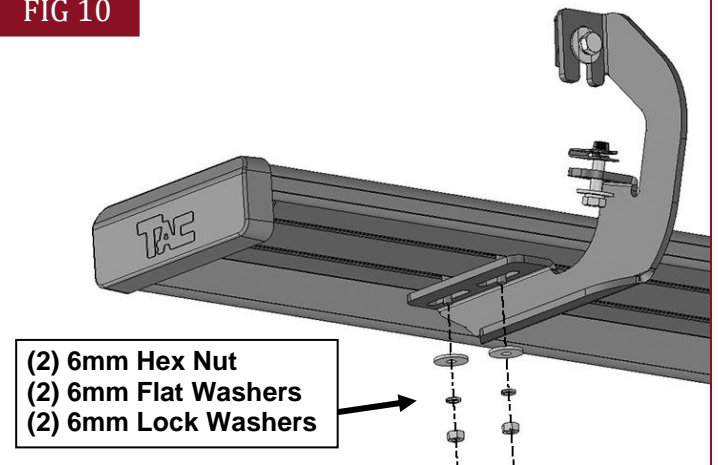

(Fig 10) Attach (1) Running board to the Mounting Brackets

STEP 6

Level and adjust the Running Board and tighten all hardware

STEP 7

Move to the Passenger/Right side of the vehicle. Determine if the vehicle is equipped with a plastic diesel exhaust fluid (DEF) tank, (Figs 11 & 13).

(1) **Models without DEF tank, skip to Step 8.**

(2) **Models with DEF tank:**

The tank sits close to the side of the body. With specialized tools, the Passenger/Right Front Upper and Lower Mounting Brackets can be installed but room is very limited. Determine model year of vehicle before proceeding.

2.1) **Up to 2016 models:**

It may be easier to drop the tank down to access the inner side of the body panel for upper bracket installation. Tank will not need to be removed, only dropped down for access to mounting location. **IMPORTANT:** If tank is full, it will be very heavy and assistance is highly recommended to avoid injury or damage to the vehicle or the tank. It is recommended that installation is performed when the DEF tank is low on fluid before dropping the tank.

- On models with plastic lower tray under the tank, remove the inside (3) hex bolts attaching the tray to the frame, (Fig 11), and remove the tray.
- Release the tank filler hose. Release the plug for the sending unit on the top of the tank.
- Support the tank with a floor jack. Place a smooth flat surface, (wooden block for example), between the floor jack and the tank to avoid damaging the plastic tank. Do not push up on the tank; only support the weight of the tank with the jack.
- Remove the outside (2) bolts securing the tank straps to the vehicle, (Fig 12). Tilt the straps to release from the brackets. Slowly lower the tank until the top of the tank is almost visible. Use blocks or stands to support the tank while installing the Front Upper and Lower Brackets.
- Proceed to **Step 8.**

2.2) **On 2017 models and on:**

- If necessary, remove the (4) hex bolts attaching plastic cover to DEF tank, (Fig 13) and remove plastic cover for better access, (Fig 14). **NOTE:** On 2017-on 2500/3500 models, only remove plastic cover from DEF tank. **Do not lower DEF tank** and proceed to **Step 8.**

FIG 11

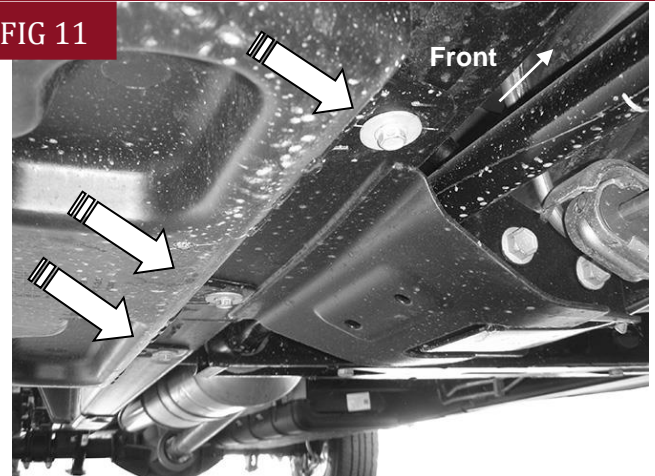

(Fig 11) 07-16 Passenger side front pictured with DEF tank cover. Remove inside (3) hex bolts to remove the tray

FIG 12

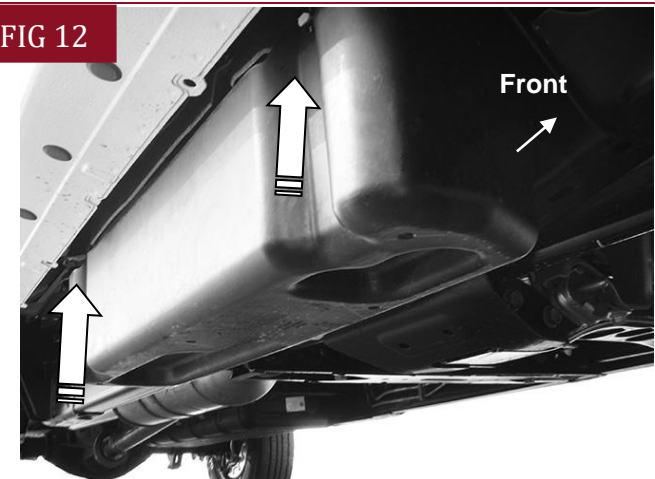

(Fig 12) 07-16 Passenger side DEF Tank and Cover. Remove outside (2) factory bolts to remove tank straps

FIG 13

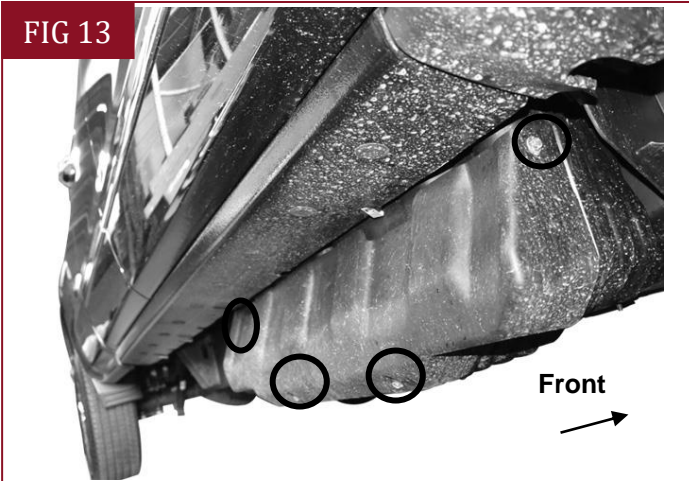

(Fig 13) 2017-on Passenger side pictured with DEF plastic tank cover. If needed, remove (4) hex bolts to remove plastic cover.

FIG 14



(Fig 14) 2017 Passenger side DEF cover removed

STEP 8

Locate the first tab on the edge of the pinch weld. Select the Upper Bracket. Repeat **Steps 2 & 3** to attach the Passenger/Right Front Upper Mounting Bracket to the side of the rocker panel, (Fig 15). Do not tighten hardware.

FIG 15



(Fig 15) Slide Upper Bracket over weld nut if equipped

STEP 9

Line up the hole in the bottom of the Upper Bracket with the hole in the tab on the pinch weld.

(1) Models with a weld-nut:

Slide the Bracket over the weld-nut. Attach the Lower Bracket to the bottom of the body and weld-nut with (1) 8mm x 25mm Hex Bolt, (1) 8mm Lock Washer, (1) 8mm x 24mm Flat Washer, (Figs 15 & 16). Do not tighten hardware.

(2) Models with flat tab and hole:

Insert the 8mm Bolt Plate down through the hole in the Upper Bracket and tab. Attach the Lower Bracket to the bottom of the body and Bolt Plate with (1) 8mm x 24 mm Flat Washer and (1) 8mm Nylon Lock Nut, (Fig 17). Do not tighten hardware.

FIG 16

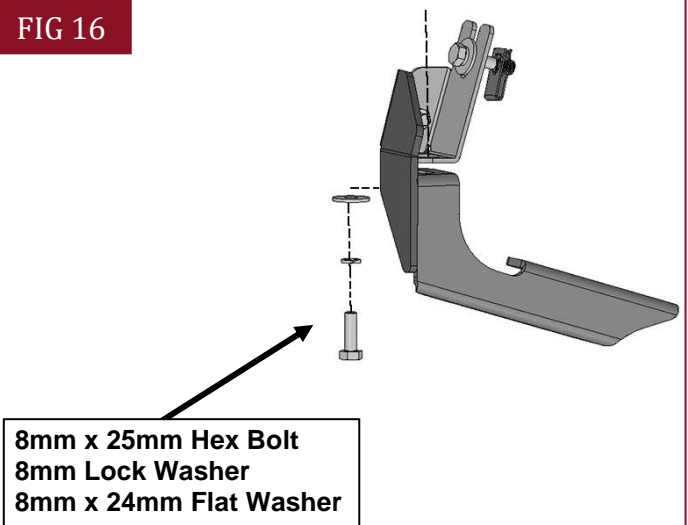

(Fig 16) For models with welded nut in the pinch weld

FIG 17

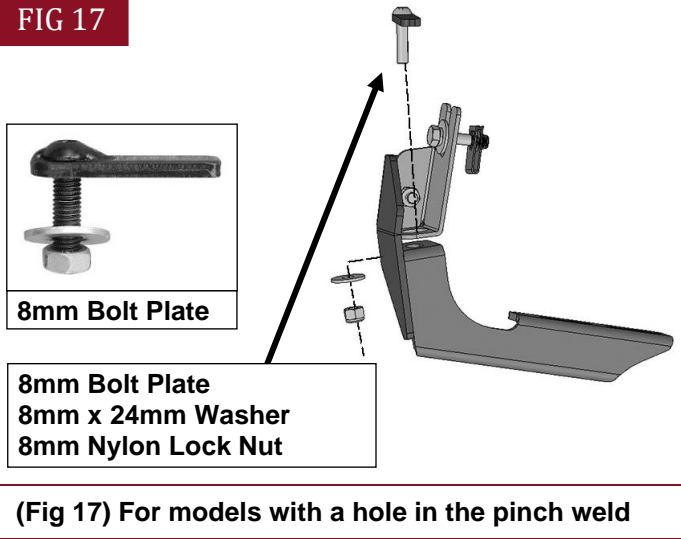

STEP 10

Secure the front of the Lower Bracket to the Upper Bracket with (1) 8mm x 25mm Hex Bolt, (1) 8mm Lock washer and (1) 8mm x 24mm Flat Washer, (Fig 18). Do not tighten hardware.

FIG 18

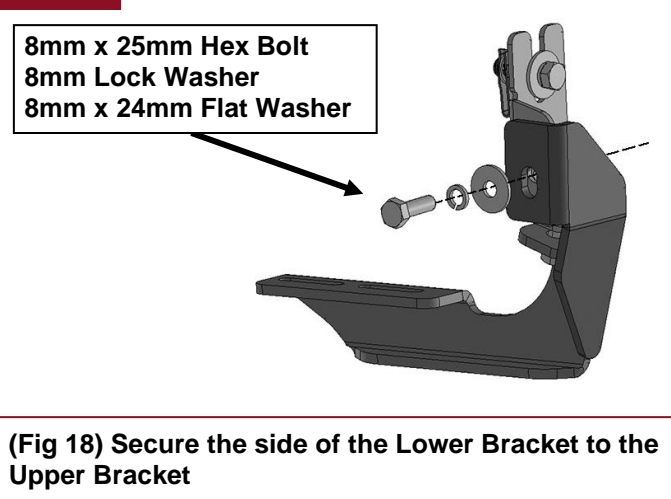

STEP 11

Repeat **Steps 1—3** to attach the remaining (1) Mounting Brackets to the Passenger/Right rocker panel. **NOTE:** Passenger/right rear Bracket is the same as the (2) driver/left Mounting Brackets.

STEP 12

For 2017-on 2500/3500 DEF tank models:

Locate the rear mounting location along the bottom edge of the body, (pinch weld). Hold the DEF cover in place and mark the location of the Bracket onto the cover, (Fig 19). Use a sharp knife or hacksaw blade to carefully cut a slot in the plastic cover to clear the 2nd Bracket, (Fig 20). Remove as little plastic as possible.

FIG 19

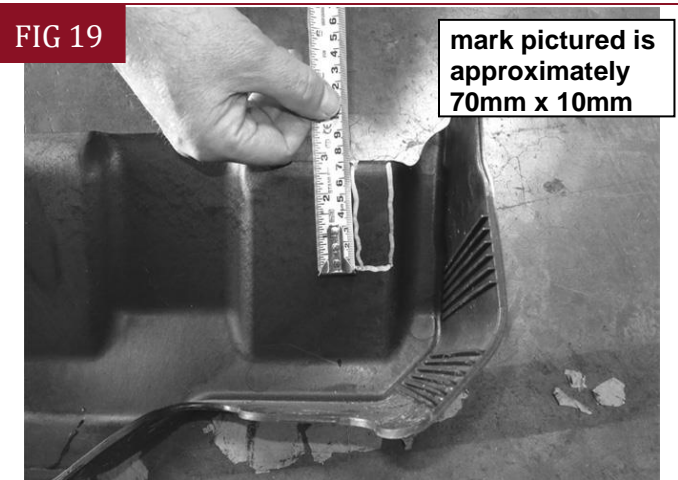

(Fig 19) 2017-on Passenger side DEF cover marked for trimming

FIG 20

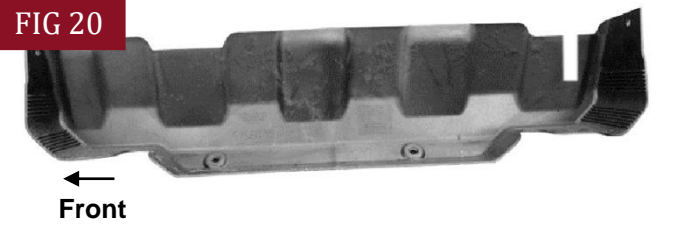

(Fig 20) 2017-on Passenger DEF cut for example only

STEP 13

Repeat **Step 5** to attach the other side Running Board.

STEP 14

Once the Sidebar has been attached and all hardware fully tightened, reinstall the DEF tank and cover, if equipped, as described in **Step 7**.

STEP 15

Do periodic inspections to the installation to make sure that all hardware is secure and tight.

Attention

To protect your investment, do not use any type of polish or wax that may contain abrasives that could damage the finish.

Mild soap may be used also to clean the Running Boards.