



SPEAR RUNNING BOARD

PART #: TAC-CA6-001

FITS: 2015-Up Chevy Colorado Crew Cab
2015-Up GMC Canyon Crew Cab



60-120 min





Cutting Not Required



Drilling Not Required

Torque & Tools

Fastener Size	Tightening Torque (ft-lbs)	Wrench Required	Allen Wrench Required	
				
<input checked="" type="checkbox"/> 6mm	<input checked="" type="checkbox"/> 7-8.5		<input checked="" type="checkbox"/> 10mm	<input type="checkbox"/> 4mm
<input checked="" type="checkbox"/> 8mm	<input checked="" type="checkbox"/> 18-20		<input checked="" type="checkbox"/> 13mm	<input type="checkbox"/> 5mm
<input type="checkbox"/> 10mm	<input type="checkbox"/> 35-40		<input type="checkbox"/> 16mm	<input type="checkbox"/> 6mm
<input type="checkbox"/> 12mm	<input type="checkbox"/> 60-70		<input type="checkbox"/> 18mm	<input type="checkbox"/> 8mm

BEFORE INSTALLATION

REMOVE CONTENTS FROM BOX. VERIFY ALL PARTS ARE PRESENT. READ INSTRUCTIONS CAREFULLY BEFORE STARTING INSTALLATION. ASSISTANCE IS RECOMMENDED.

Part List

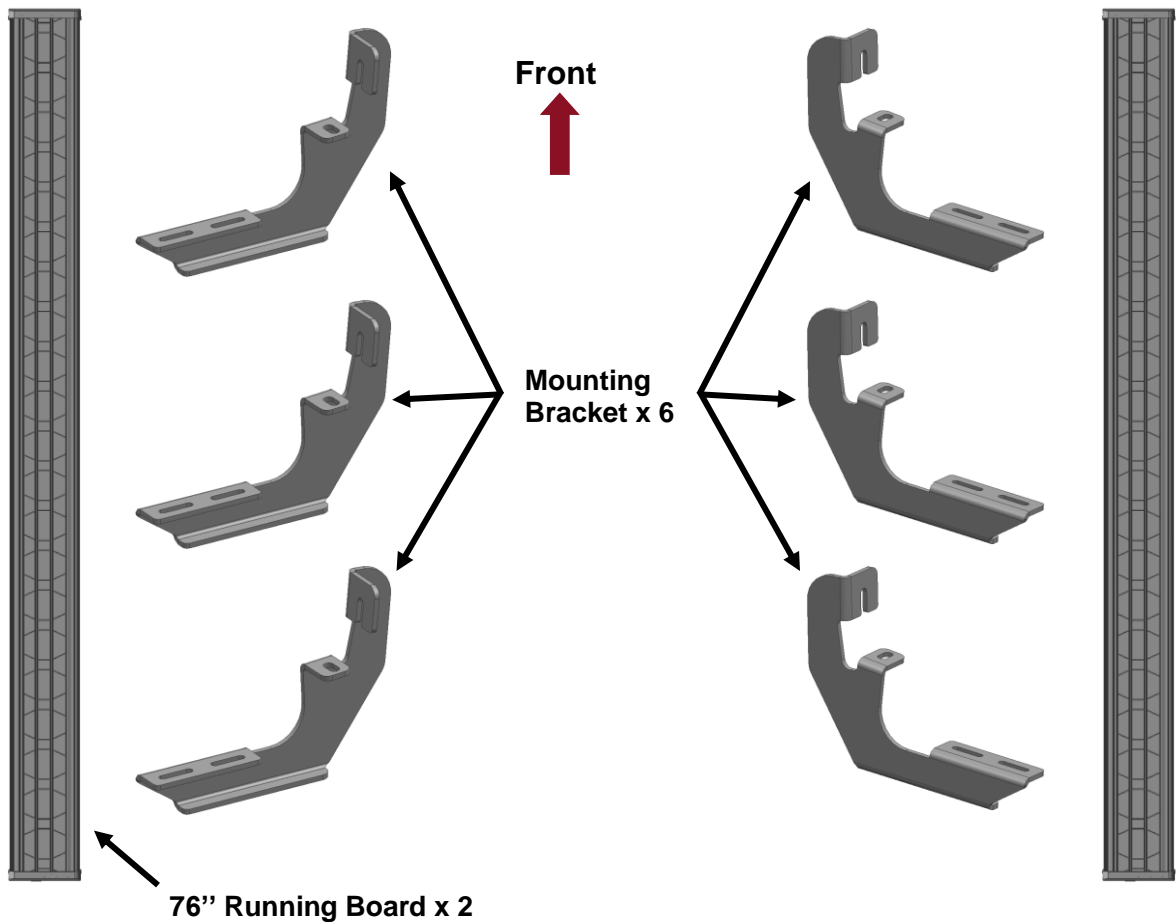



8mm x 25mm
Hex Bolt



8mm x 24mm
Flat Washer



8mm Lock
Washer

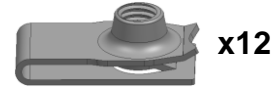

8mm Clip
Nut



6mm x 20mm
T-Bolt



6mm x 22mm
Flat Washer



6mm Lock
Washer



6mm Hex
Nut

PLEASE NOTE THAT THE FOLLOWING PICTURES ARE BASED ON THE PASSENGER SIDE INSTALLATION

STEP 1

Start the installation under the Passenger/Right side of the vehicle. Locate the front mounting location along the bottom and inner side of the body panel, **(Fig 1)**. Installation will use the 1st, 2nd and 4th mounting locations. **NOTE:** It may help to hold a Bracket up in place to help determine the mounting holes to use along the bottom and inner side of the body.

FIG 1

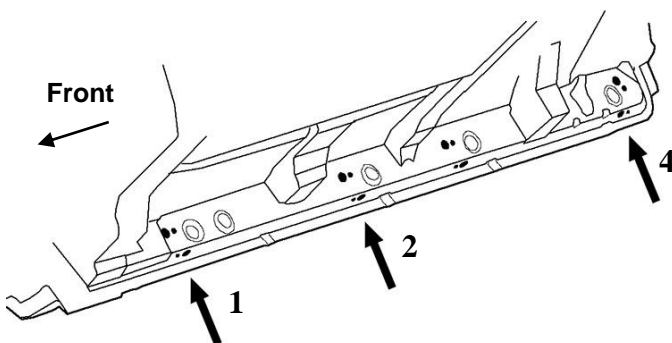

(Fig 1) Passenger side mounting locations along bottom and back of body panel illustrated

STEP 2

Remove rubber plugs as necessary from the holes in the side and bottom of the inner body panel, **(Fig 2)**.

FIG 2

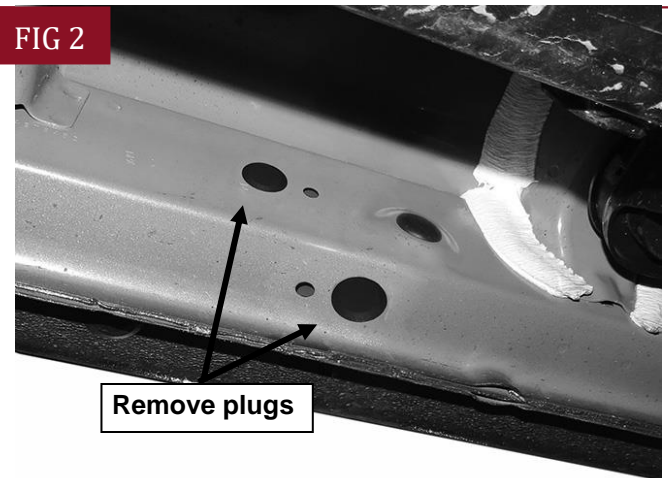

(Fig 2) Remove plugs from the Passenger/Right front mounting locations as necessary

STEP 3

Select (2) 8mm Clip Nuts. Slide each Clip Nut into the large hole and over the smaller hole next to it. Line up threaded nut on the Clip Nut with smaller hole in body panel, **(Fig 3)**

FIG 3

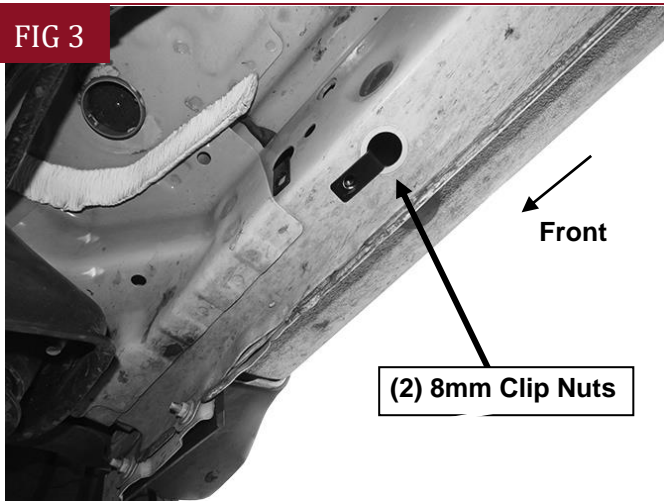

(Fig 3) Slide 8mm Clip Nut into large hole and over small hole

STEP 4

Select (1) Mounting Bracket. Attach the Mounting Bracket to the (2) Clip Nuts in the vehicle with (2) 8mm Hex Bolts, (2) 8mm Lock Washers and (2) 8mm Flat Washers, **(Fig 3 & 4)**. Do not tighten hardware.

FIG 4

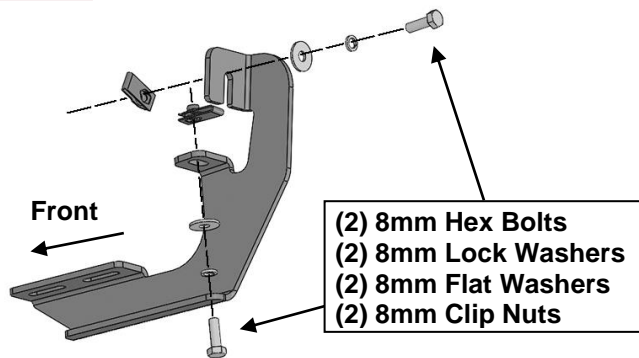

(Fig 4) Attach (1) Mounting Bracket to the Clip Nuts

STEP 5

Repeat **Steps 1—4** to attach the remaining (2) Mounting Bracket to the 2nd and rear locations, **(Figs 5 & 6)**. Do not tighten hardware.

FIG 5



(Fig 5) Remove plugs from the Passenger/Right center mounting location

FIG 6



(Fig 6) Remove plugs from the Passenger/Right rear mounting location

STEP 6

Select (1) Running Board. Insert (6) 6mm T-Bolts into the channels in the bottom of the Running Board, (**Fig 7**), (3 T-Bolts per channel). Attach the Running Board to the (3) Mounting Brackets with (6) 6mm Flat Washers, (6) 6mm Lock Washers and (6) 6mm Hex Nuts, (**Fig 8**). Do not tighten hardware.

FIG 7

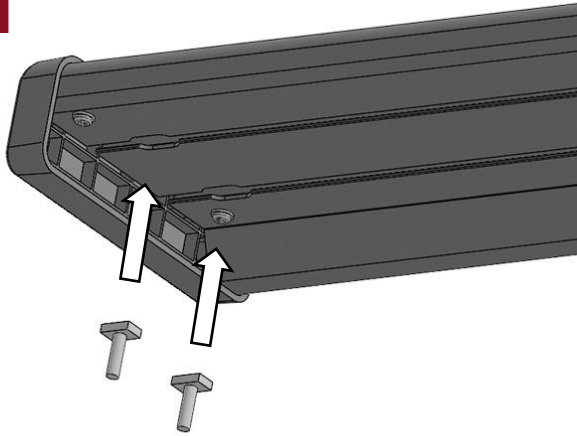

(Fig 7) Insert (6) 6mm T-Bolts into the channels in the bottom of the Side Step, (3 T-Bolts per channel)

FIG 8

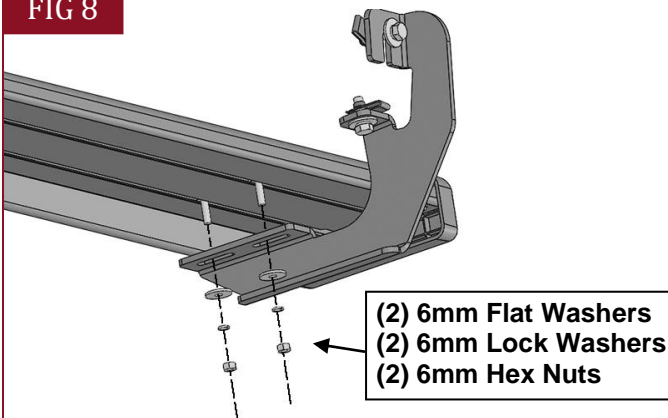

(Fig 8) Attach (1) Running Board the (3) Mounting Brackets

STEP 7

Level and adjust the Running Board and fully tighten all hardware.

STEP 8

Repeat **Steps 1—7** to attach the other side Running Board.

STEP 9

Do periodic inspections to the installation to make sure that all hardware is secure and tight.

Attention

To protect your investment, do not use any type of polish or wax that may contain abrasives that could damage the finish.

Mild soap may be used also to clean the Running Boards.