



## **INSTALLATION INSTRUCTIONS**

**EC1 MODULAR BULL BAR**

**2019-2024 DODGE RAM 1500**

**(Excluding Rebel Trim/19-24 RAM 1500 Classic/20-22 Ram 1500 Diesel Models)**

**PART# EC1-D114TM**

**TRUCK ACCESSORIES COMPANY**

**PARTS LIST:**

1	Driver/Left Side Bull Bar Upright	4	12mm Lock Washers
1	Passenger/Right Side Bull Bar Upright	4	12mm Hex Nuts
1	Top Cross Bar	12	10-1.5mm x 25mm Hex Bolts
1	Center Cross Bar	4	10mm x 30mm x 3mm Flat Washers
1	Driver/Left Side Frame Bracket	16	10mm x 20mm x 2mm Flat Washers
1	Passenger/Right Side Frame Bracket	12	10mm Lock Washers
1	Driver/Left Side Support Bracket	8	10-1.5mm Hex Nuts
1	Passenger/Right Side Support Bracket	6	8-1.25mm x 30mm Hex Bolts
1	Driver/Left Side Bull Bar Bracket	4	8-1.25mm x 25mm Hex Bolts
1	Passenger/Right Side Bull Bar Bracket	2	8-1.25mm x 16mm Hex Bolts
1	Mesh Fill Panel	18	8mm x 24mm OD x 2mm Flat Washers
2	LED Light "L" Brackets	12	8mm Lock Washers
1	License Plate Bracket	8	8mm Hex Nuts
2	Black Rubber Self-Adhesive Top Seal	2	6mm Combo Bolts
2	Black Rubber Self-Adhesive Center Seal	2	6-1.0mm x 20mm Button Head Bolts
2	8mm x 30mm Bolt Plates	4	6mm x 18mm OD x 1.6mm Flat Washers
2	8mm Plastic Retainers	2	6mm Lock Washers
4	12-1.75mm x 35mm Hex Bolts	2	6mm Hex Nuts
8	12mm x 32mm OD x 3mm Flat Washers	1	4mm Wrench

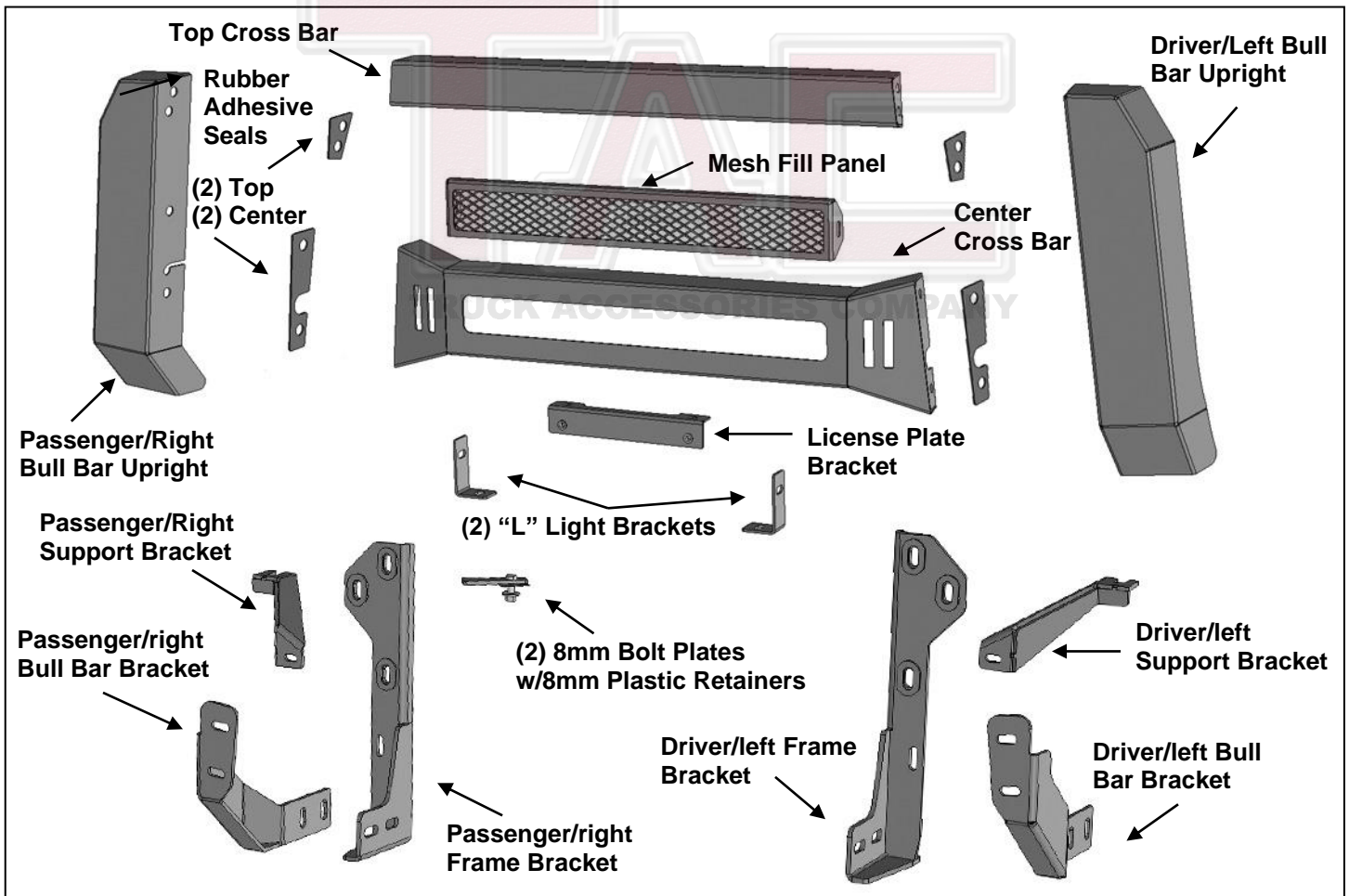

**PROCEDURE:**

**REMOVE CONTENTS FROM BOX. VERIFY ALL PARTS ARE PRESENT. READ INSTRUCTIONS CAREFULLY BEFORE STARTING INSTALLATION. CUTTING IS REQUIRED. ASSISTANCE IS RECOMMENDED. INSTALLATION MAY INTERFERE WITH FRONT BUMPER MOUNTED SENSORS.**

1. Start installation under the front bumper. Carefully remove the plastic lower air dam attached to the bottom of the bumper. Do not remove the electronic “active air dam” behind the bumper if equipped. Pay close attention to the type and location of all factory hardware for reinstallation.
2. Move to the back of the driver/left side of the bumper, **(Figure 1)**. Select (1) 8mm Bolt Plate and (1) 8mm Plastic Retainer. Insert the Bolt Plate into the space between the outer bumper cover and bumper bracket, **(Figures 2 & 3)**. Insert the threaded part of the Bolt Plate back through the hole in the bumper bracket. Thread the Plastic Retainer onto the Bolt Plate to hold it in place position. **NOTE:** The Plastic retainer is used to help hold the Bolt Plate in place but use is not mandatory for Bracket installation.
3. Next, Remove the (2) factory hex bolts attaching the bumper to the bumper bracket, **(Figure 2)**. Select the driver/left Frame Mounting Bracket. Attach the Bracket to the back of the bumper with the included longer (2) 8mm x 30mm Hex Bolts, (2) 8mm Lock Washers and (2) 8mm Flat Washers, **(Figure 3)**. Attach the Bracket to the 8mm Bolt Plate with (1) 8mm Flat Washer, (1) 8mm Lock Washer and (1) 8mm Hex Nut. Do not fully tighten hardware at this time.
4. Loosen but do not remove the hex bolt from the bottom of the frame, **(Figures 1 & 5)**. Select the driver/left Support Bracket, **(Figure 4)**. Insert the slotted end of the Bracket under the hex bolt.
  - a. On models with tow hooks, slide the Bracket between the head of the hex bolt and the large flat washer, **(Figure 5)**. Do not tighten hex bolt at this time.
  - b. On models without tow hooks, slide the Bracket between the steel sleeve on the frame and the head of the hex bolt, **(Figures 1 & 4)**.
5. Line up the lower end of the Support Bracket with the slot in the Frame Bracket. Attach the Support Bracket to the Frame Bracket with (1) 8mm x 30mm Hex Bolt, (2) 8mm Flat Washers, (1) 8mm Lock Washer and (1) 8mm Hex Nut, **(Figure 4)**.
6. Repeat **Steps 2—5** to install the passenger/right Frame and Support Bracket.
7. Select the driver side Bull Bar Upright and the Top Cross Bar. Attach the Black Rubber Self-Adhesive Top Seal between the Upright and Top Cross Bar. Bolt through the Top Cross Bar, Self-Adhesive Top Seal and Upright using (2) 10mm x 25mm Hex Bolts, (4) 10mm x 20mm Flat Washers, (2) 10mm Lock Washers and (2) 10mm Hex Nuts, **(Figure 6)**. Do not fully tighten hardware.
8. Select the Center Cross Bar. Attach the Black Rubber Self-Adhesive Center Seal between the Upright and the Center Cross bar. Bolt through the Center Cross Bar, Self-Adhesive Center Seal, and Upright with (2) 10mm x 25mm Hex Bolts, (4) 10mm x 20mm Flat Washers, (2) 10mm Lock Washers and (2) 10mm Hex Nuts, **(Figure 6)**. Do not fully tighten hardware.
9. Repeat **Steps 7 & 8** to attach the passenger side Bull Bar Upright to the Top Cross Bar and Center Cross Bar. Place assembled Bull Bar face down on a clean flat surface and fully tighten top and center cross bar to upright hardware only at this time.
10. Relocation of front license plate may be necessary.
  - a. Attach the License Plate Bracket to bottom of Center Cross Bar with (2) 6mm Button Head Bolts, (4) 6mm Flat Washers, (2) 6mm Lock Washers and (2) 6mm Hex Nuts, **(Figure 7)**.
  - b. Attach license plate to Bracket with (2) 6mm Button Head Combo Bolts, **(Figure 7)**.
11. LED light installation, (optional-light available separately).
  - a. Start at the driver/left side of the vehicle. Select (1) Light Bar “L” Bracket. Attach the Bracket to the slot in the back of the Center Cross Bar with (1) 8mm x 25mm Hex Bolt, (2) 8mm Flat Washers, (1) 8mm Lock Washer and (1) 8mm Hex Nut, **(Figure 8)**. **NOTE:** Check for clearance between the Hex Bolt and the bottom of the Light. If necessary, insert the Hex Bolts down through the Brackets then through slots in the Cross Bar. Leave hardware loose at this time.
  - b. Repeat the previous **Step** to attach the passenger/right Light Bracket.
  - c. If needed, use the included (2) 8mm x 16mm Hex Bolts, (2) 8mm Lock Washers and (2) 8mm Flat Washers to attach the LED light bar to the Brackets, **(Figure 8)**.

(Excluding Rebel Trim/19-24 RAM 1500 Classic/20-22 Ram 1500 Diesel Models)

- d. Follow light manufacturer's instructions to properly wire the light bar to the electrical system.
- e. Proceed to **Step 13**.
12. Center Screen Fill Panel Installation, (cannot be installed with LED light).
  - a. Select (1) "L" Light Bar Bracket. Attach the Bracket to the outside of the tab on the Center Screen Fill Panel with (1) 8mm x 25mm Hex Bolt, (2) 8mm Flat Washers, (1) 8mm Lock Washer and (1) 8mm Hex Nut, (**Figure 9**). **NOTE:** Insert the Hex Bolt through the tab on the Panel and out through the Bracket. Repeat to attach the remaining Bracket to the other end of the Fill Panel. Leave hardware loose.
  - b. Attach the Fill Panel with Brackets to the slots in the back of the Center Cross Bar with (2) 8mm x 25mm Hex Bolts, (4) 8mm 24mm Flat Washers, (2) 8mm Lock Washers and (2) 8mm Hex Nuts, (**Figure 9**). **NOTE:** Insert the Hex Bolts up through the bottom of the Cross Bar.
  - c. Push the Fill Panel up tight against the inside of the opening and fully tighten hardware.
13. Select the driver/left Bull Bar Bracket. Attach the Bracket to the (2) bottom holes in the Upright on the Bull Bar assembly with (2) 10mm x 25mm Hex Bolts, (2) 10mm Lock Washers and (2) 10mm x 30mm Large Flat Washers (**Figures 10 & 11**). Do not fully tighten hardware. Repeat this Step to attach the passenger/right Bull Bar Bracket.
14. With assistance, hold the assembled Bull Bar up to the outside of the Brackets. Attach the Bull Bar to the Mounting Brackets with the included (4) 12mm x 35mm Hex Bolts, (8) 12mm Flat Washers, (4) 12mm Lock Washers and (4) 12mm Hex Nuts, (**Figures 12—14**). Do not tighten hardware.
15. Stand back from the vehicle and check to see that the Bull Bar is centered and leveled on the vehicle. Adjust as necessary. Tighten only the hardware securing the Bull Bar Brackets and Mounting Brackets to the truck. Do not tighten the hardware on the Bull Bar.
16. Temporarily remove the Bull Bar with Brackets attached.
17. Hold the plastic air dam up to the bumper and align it with the mounting points. Mark the location of the Mounting Brackets onto the back of the air dam, (**Figure 15**). Cut an approximately 1-1/2" wide slot out of the bottom of the air dam. **NOTE:** The size of the slot is an estimate only and may vary due to different factory designs for the air dam and front bumper covers. **IMPORTANT:** To avoid weakening the air dam, do not cut the slot any larger than necessary to clear Brackets only. Do not cut through the top edge or mounting points, (**Figure 15**). Make several small cuts first and check the fit often for a clean installation.
18. Reinstall the air dam using the factory hardware. **NOTE:** It may be necessary to loosen the Bracket hardware to reinstall the air dam.
19. Reinstall the Bull Bar as described in **Step 14**.
20. Level and adjust the Bull Bar and fully tighten all hardware.
21. Do periodic inspections to the installation to make sure that all hardware is secure and tight.

**To protect your investment,** Do not use any type of polish or wax that may contain abrasives that could damage the finish. Mild soap may be used to clean the Bull Bar.

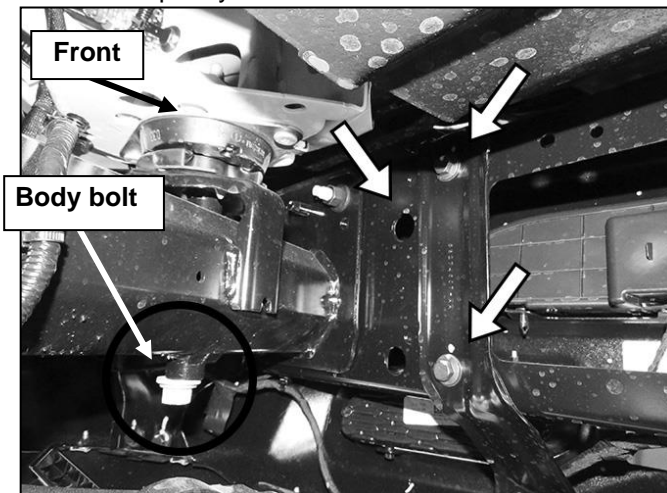

(Fig 1) Driver/left mounting location pictured from behind bumper

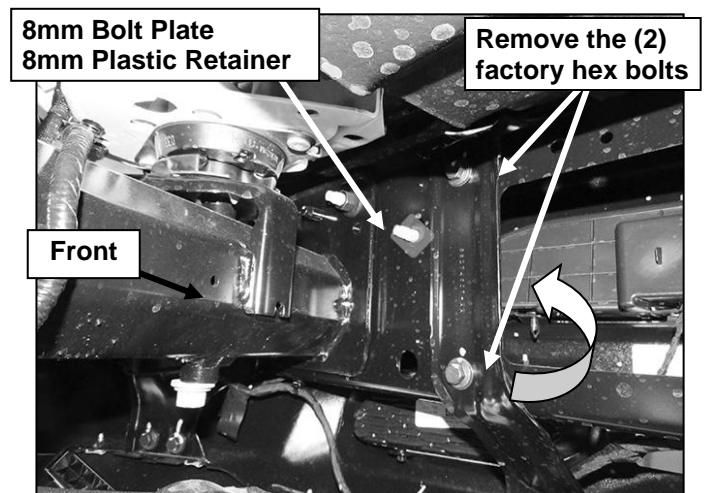

(Fig 2) Insert Bolt Plate back through bumper bracket (arrow)

### Driver/left Side Installation Pictured

- (2) 8mm x 30mm Hex Bolts
- (2) 8mm Lock Washers
- (2) 8mm Flat Washers

- 8mm Flat Washer
- 8mm Lock Washer
- 8mm Hex Nut

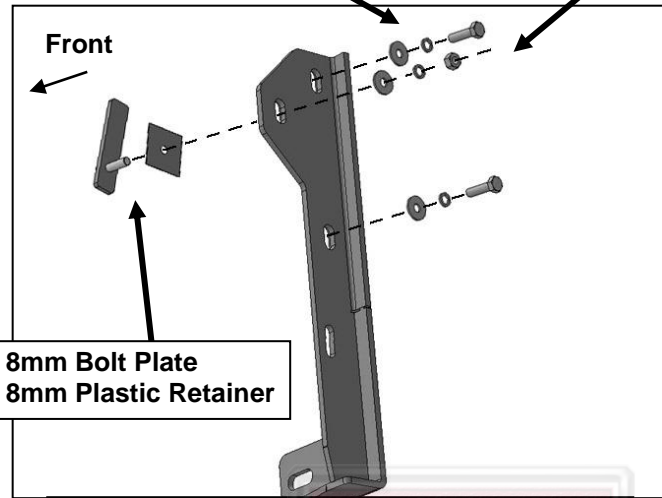

(Fig 3) Driver/left side Frame Bracket layout

- 8mm x 30mm Hex Bolt
- (2) 8mm Flat Washers
- 8mm Lock Washer
- 8mm Hex Nut

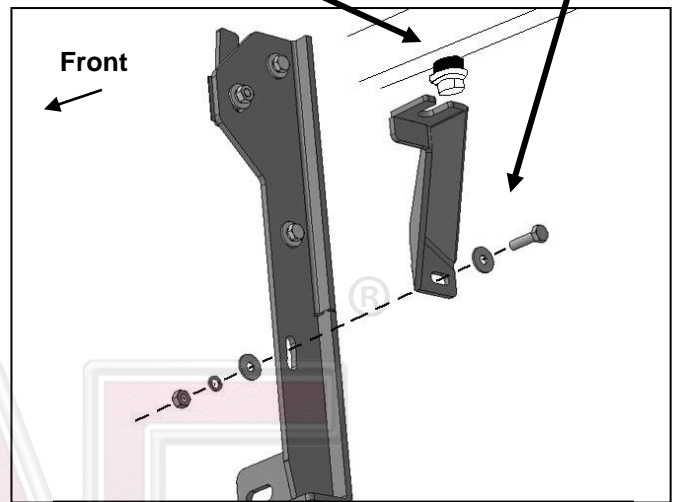

(Fig 4) Driver/left side Support Bracket attached to factory bolt and Frame Bracket

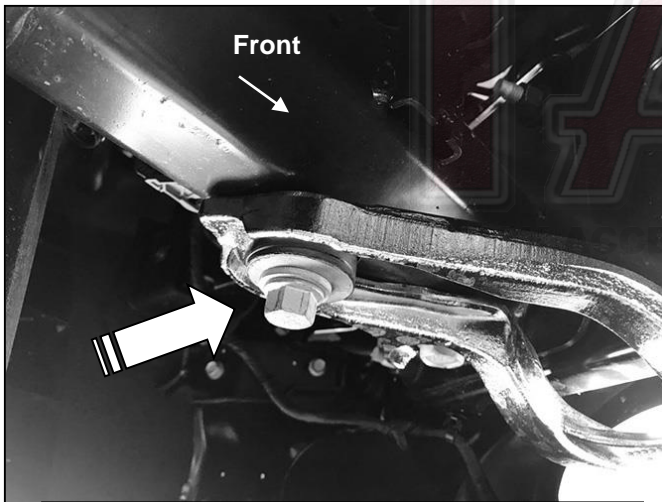

(Fig 5) Models with tow hook, loosen rear bolt (arrow) and slide top of Support Bracket between head of bolt and large flat washer

- (4) 10mm x 25mm Hex Bolts
- (8) 10mm x 20mm Flat Washers
- (4) 10mm Lock Washers
- (4) 10mm Hex Nuts

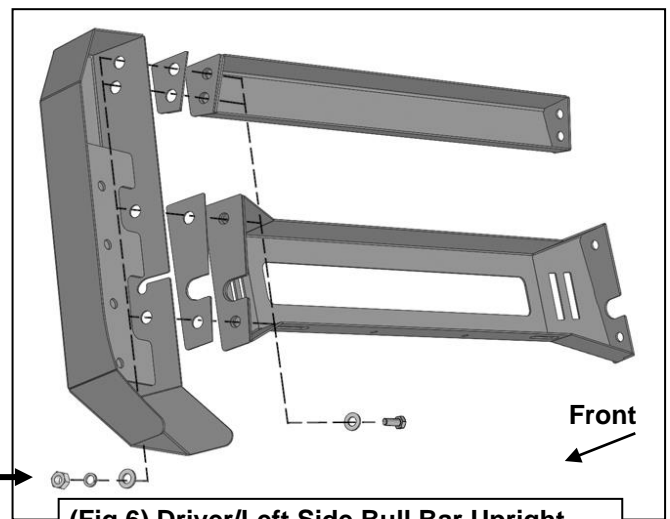

(Fig 6) Driver/Left Side Bull Bar Upright attached to Top and Center Cross Bars

**Driver/left Side Installation Pictured**

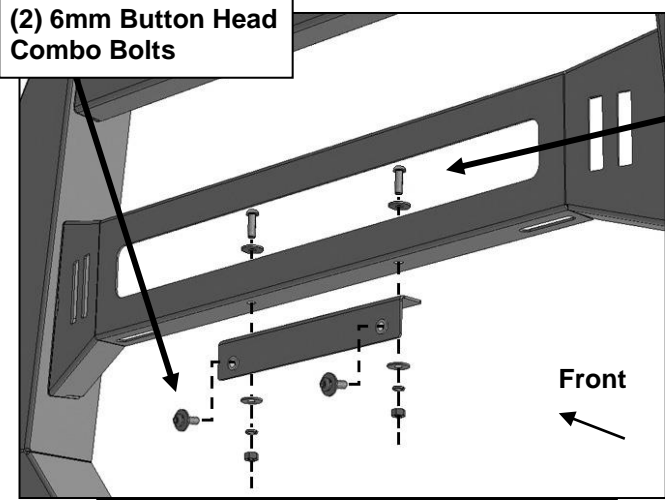

(2) 6mm Button Head Combo Bolts

Front

(Fig 7) Attach License Plate Bracket to bottom of Center Cross Bar

(2) 6mm Button Head Bolts  
 (4) 6mm Flat Washers  
 (2) 6mm Lock Washers  
 (2) 6mm Hex Nuts

8mm x 16mm Hex Bolt  
 8mm Lock Washer  
 8mm Flat Washer

8mm x 25mm Hex Bolt  
 (2) 8mm Flat Washers  
 8mm Lock Washer  
 8mm Hex Nuts

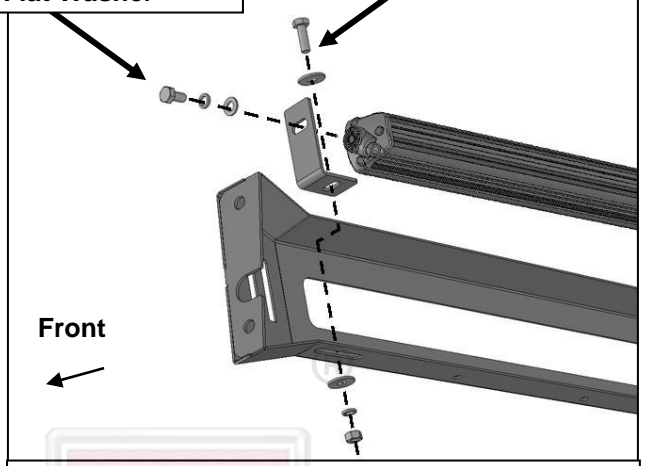

Front

(Fig 8) Optional LED light available separately

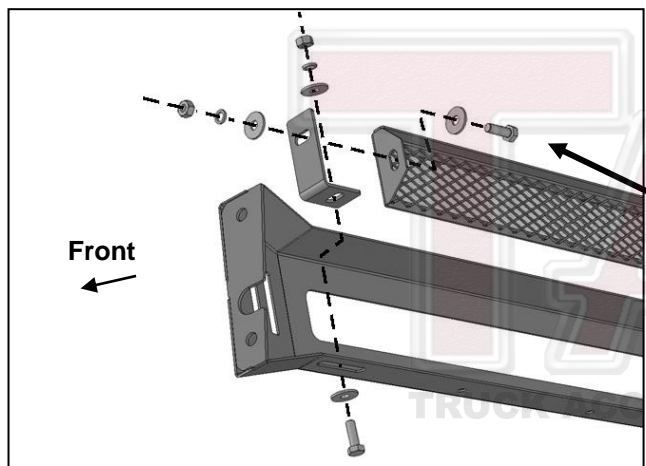

Front

8mm x 25mm Hex Bolt  
 (2) 8mm Flat Washers  
 8mm Lock Washer  
 8mm Hex Nut

(2) 8mm x 30mm Hex Bolts  
 (2) 8mm Lock Washers  
 (2) 8mm Flat Washers

(Fig 9) Attach Center Fill Panel to "L" Brackets

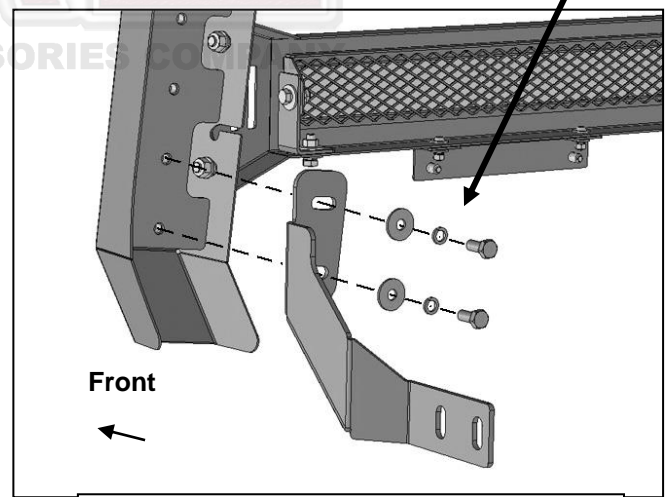

Front

(Fig 10) Attach Bull Bar Bracket to lower mounting holes on back of Bull Bar

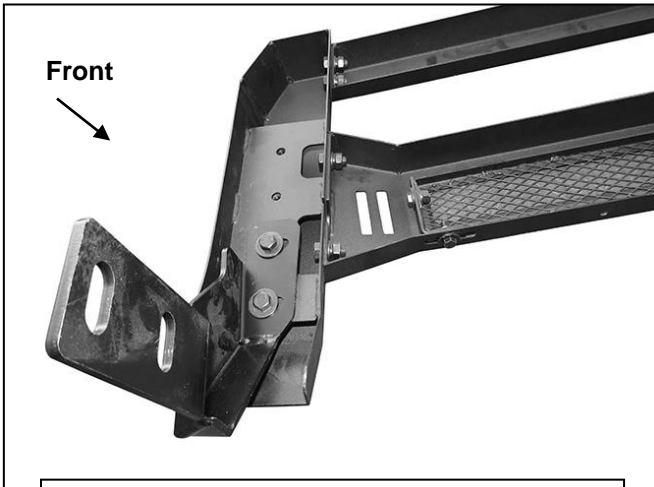

Front

(Fig 11) Attach Bull Bar Bracket to Bull Bar

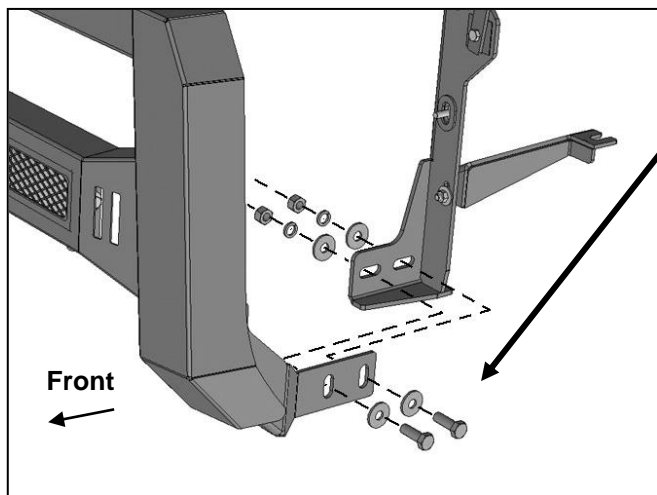

- (2) 12mm x 35mm Hex Bolts
- (4) 12mm Flat Washers
- (2) 12mm Lock Washers
- (2) 12mm Hex Nuts

(Fig 12) Attach Bull Bar with Brackets to outside of Frame Bracket (Driver/left side illustrated)

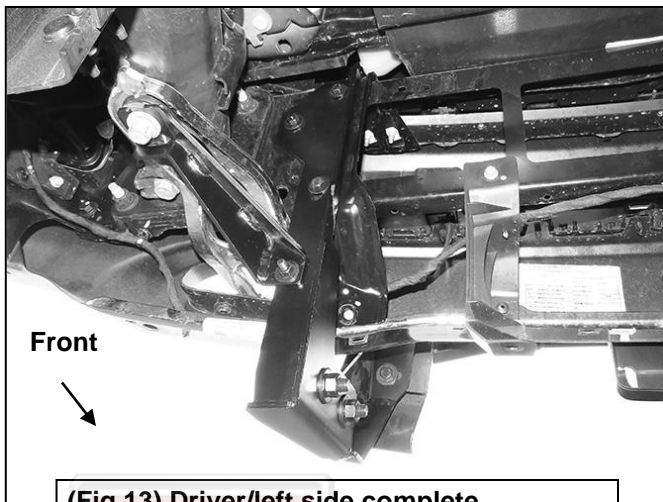

(Fig 13) Driver/left side complete installation pictured from behind bumper

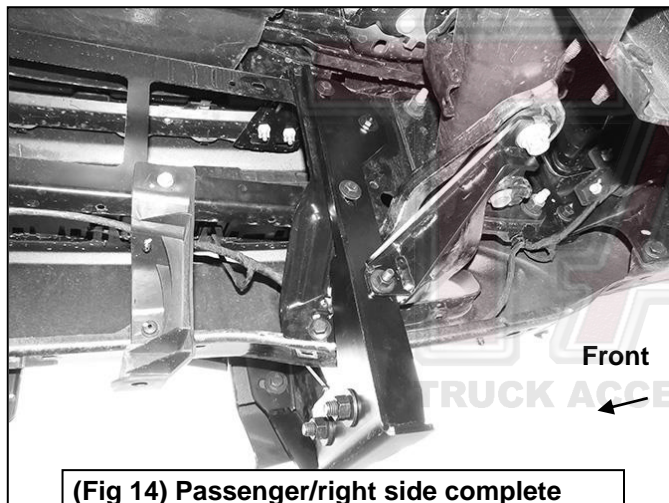

(Fig 14) Passenger/right side complete installation pictured from behind bumper

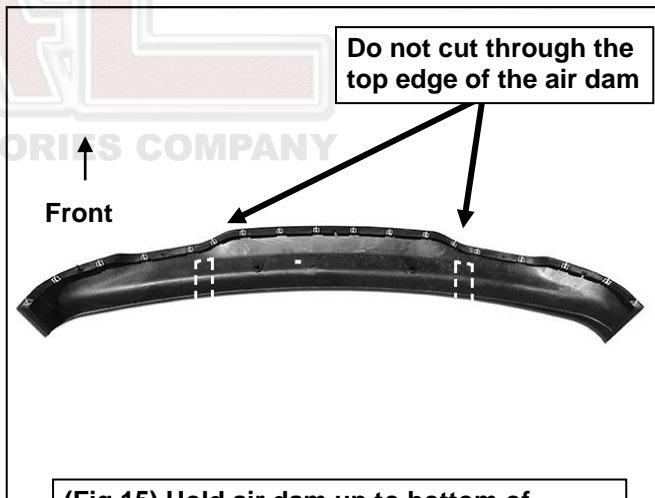

(Fig 15) Hold air dam up to bottom of Brackets. Trace Bracket location onto inside of air dam. Dashed lines indicate approximate sections to cut from air dam

