



# **INSTALLATION INSTRUCTIONS<sup>®</sup>**

**SIDEBAR**

**95-04 TOYOTA TACOMA EXT. CAB 4WD OR PRERUNNER**

**PART# BA230930**

**TRUCK ACCESSORIES COMPANY**

**PARTS LIST:**

1	Driver/Left Sidebar	2	12-1.75mm x 50mm Flat Head Bolts ( <b>use on front mount</b> )
1	Passenger/Right Sidebar	2	12-1.75mm x 50mm Hex Bolts ( <b>use on rear mount</b> )
2	Rear Mounting Brackets	2	12-1.75mm x 40mm Hex Bolts
2	Front Mounting Brackets	8	12mm x 32mm OD x 3mm Flat Washers
1	Rear Offset Connector Bracket ( <b>95-98 Model</b> )	6	12mm Lock Washers
2	Straight Connector Brackets ( <b>99-04 Model</b> )	4	12mm Hex Nuts
2	Rear Top Clamps	4	10-1.50mm x 45mm Hex Bolts
2	Rear Bottom Clamps	4	10mm x 30mm OD x 2.5mm Flat Washers
2	12mm Plastic Retainers	4	10mm Lock Washers
2	12-1.75mm Bolt Plates	1	Wrench

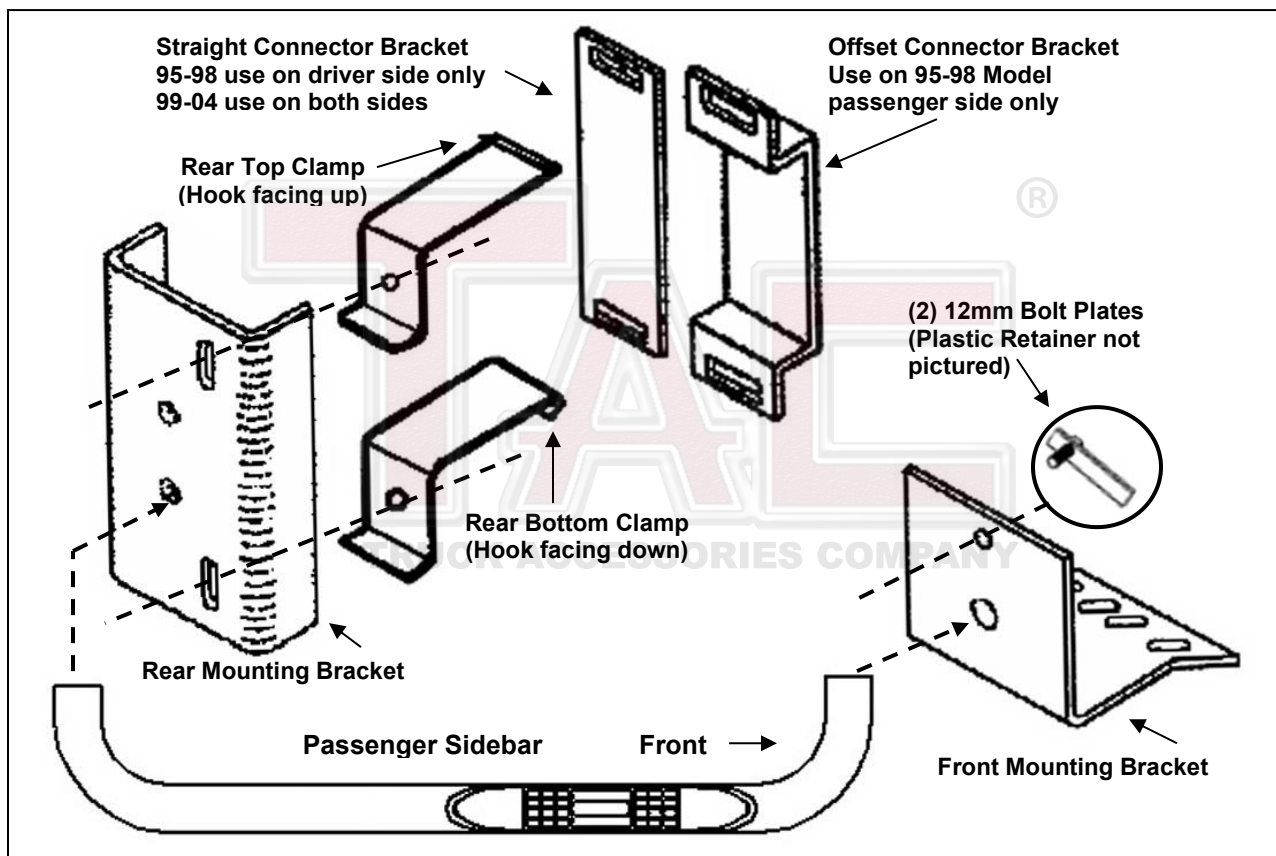

**PROCEDURE:**

1. **REMOVE CONTENTS FROM BOX. VERIFY ALL PARTS ARE PRESENT. READ INSTRUCTIONS CAREFULLY BEFORE STARTING INSTALLATION. ASSISTANCE IS RECOMMENDED.**
2. Select the passenger Sidebar and place it on a clean working area. Attach the front Mounting Bracket to the Sidebar using the included (1) 12mm x 50mm Flat Head Bolts, (**Figure 1**). **NOTE:** Use the counter sunk hole to attach the Sidebar to the front Mounting Bracket.
3. Bolt the rear Mounting Bracket to the Sidebar using the included (1) 12mm x 50mm Hex Bolt, (1) 12mm Lock Washer and (1) 12mm Flat Washer, (**Figure 2**). **NOTE:** Make sure the rear Mounting Bracket is positioned so the (2) vertical slots on the Bracket are forward, (toward front of vehicle). Use the bottom round hole on the Bracket to bolt the Bracket to the Sidebar.

4. Next, locate the factory rectangular hole in the frame towards the front of the vehicle. Thread (1) 12mm Plastic Retainer part way onto (1) 12mm Bolt Plate, **(Figure 3B)**. Insert the 12mm Bolt Plate and Retainer into the hole in the side of the frame, **(Figure 3A)**. Once inserted, thread the Plastic Retainer down tight against the side of the frame. **IMPORTANT:** The Plastic Retainer is designed to prevent the Bolt Plate from falling into the frame channel and to aid in mounting the Bracket.
5. With assistance, position the Sidebar and Brackets up to the vehicle frame and place top hole of front Mounting Bracket over previously installed Bolt Plate. Secure the Mounting Bracket to the Bolt Plate with the included (1) 12mm Lock Washer, (1) 12mm Flat Washer and (1) 12mm Hex Nut, **(Figure 4)**. Do not tighten hardware at this time.
6. Select (1) Rear Top Clamp and place it in position on top of the frame channel. Depending on your vehicle, place either the Straight Connector Bracket or the Offset Connector Bracket on the inside of the frame and hook it over the Top Clamp. **IMPORTANT:** Hook on the Top Clamp should be facing up. Hook Bottom Clamp into the Connector Bracket. **NOTE:** Hook on the Rear Bottom Clamp should be facing downward, **(Figure 5 & 6)**.  
**95-98 Extended Cab Models:** Place Offset Connector Bracket against backside of frame on the passenger side and Straight Connector Bracket against the backside of frame on the driver side.  
**99-03 Extended Cab Models:** Place Straight Connector Bracket against the backside of the frame on the passenger and driver side.
7. With assistance, hold the 3pc Clamp Assembly in place while you lift up the Sidebar and Rear Mounting Bracket. Line up the top and bottom mounting holes with the top and bottom Clamps and bolt together using the included (2) 10mm x 45mm Hex Bolts, (2) 10mm Lock Washers and (2) 10mm Flat Washers, **(Figure 7)**. Do not tighten hardware at this time.
8. Return to the front Bracket and line up one of the slots in the bottom of the front Mounting Bracket with the factory hole in the cross member. Bolt the Bracket to the crossmember with the included (1) 12mm x 40mm Hex Bolt, (1) 12mm Lock Washer, (1) 12mm Flat Washer and (1) 12mm Hex Nut, **(Figure 4)**.
9. Level and align Sidebar properly and tighten all hardware.
10. Do periodic inspections to the installation to make sure that all hardware is secure and tight.

**To protect your investment**, wax this product after installing. Regular waxing is recommended to add a protective layer over the finish. Do not use any type of polish or wax that may contain abrasives that could damage the finish.

**For stainless steel:** Aluminum polish may be used to polish small scratches and scuffs on the finish. Mild soap may be used also to clean the Sidebar.

**For gloss black finishes:** Mild soap may be used to clean the Sidebar.

### Passenger/Right Sidebar Installation Pictured

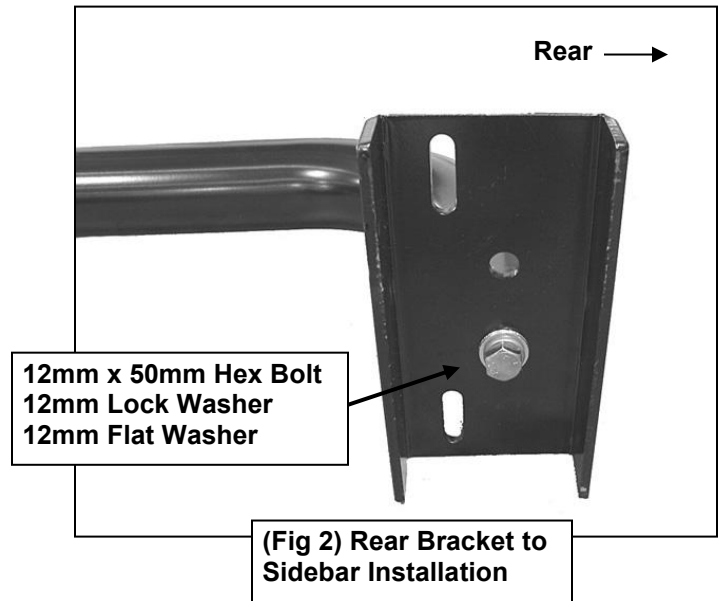
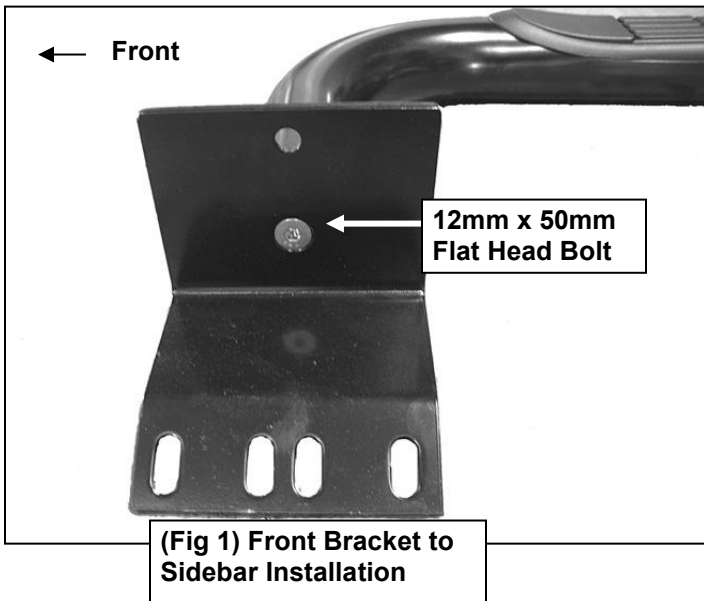

### Passenger/Right Sidebar Installation Pictured

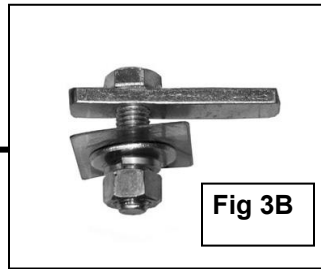
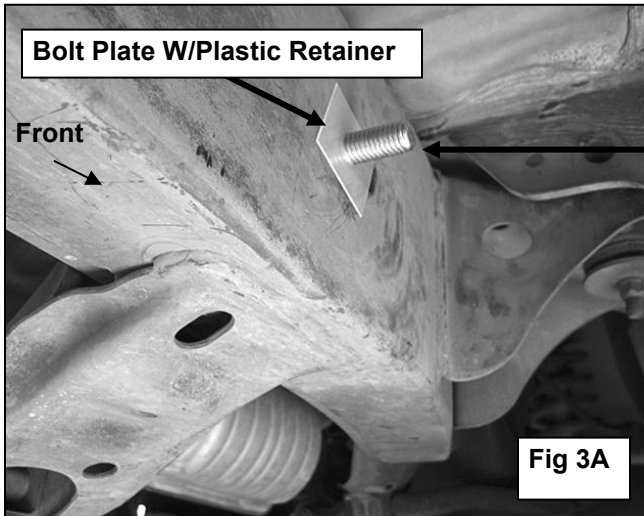

**12mm Bolt Plate  
12mm Lock Washer  
12mm Flat Washer  
12mm Hex Nut**

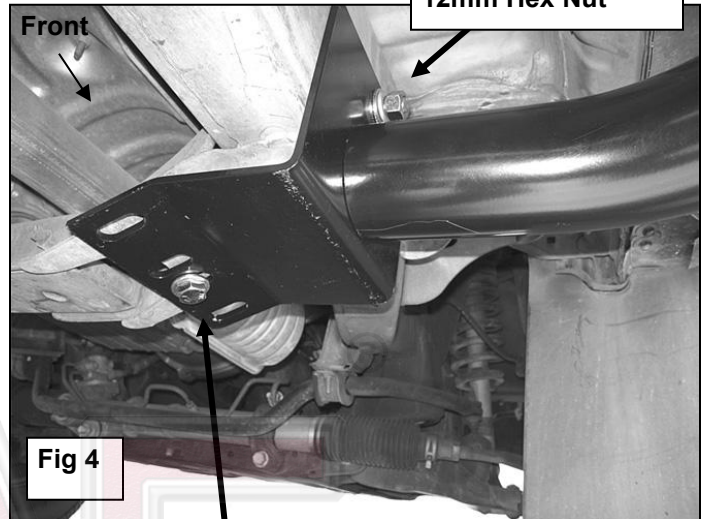

**(Install last-see Step 8)  
12mm x 40mm Hex Bolt  
12mm Lock Washer  
12mm Flat Washer  
12mm Hex Nut**

