



INSTALLATION INSTRUCTIONS

FRONT BUMPER

2007-2018 JEEP WRANGLER JK/

2018-2023 WRANGLER JL/

(EXCL. RUBICON/PLUG-IN HYBRID MODELS/2021-2023 V8 ENGINE)

2020-2023 GLADIATOR (EXCL. MOJAVE TRIM)

PART# 92440N

PARTS LIST:

1	Front Bumper Assembly	4	12mm Hex Nuts
2	Fog Light Adapter Brackets	12	4mm x 15mm Button Head Bolts
4	12mm Plastic Retainers	20	4mm x 12mm x 1mm Flat Washers
8	12mm Bolt/12mm Nut Plates	12	4mm Lock Washers
4	12mm x 30mm Hex Bolts	8	4mm Hex Nuts
8	12mm x 37mm x 3mm Flat Washers	1	2.5mm Allen Wrench (4mm)
8	12mm Lock Washers	2	D-Rings

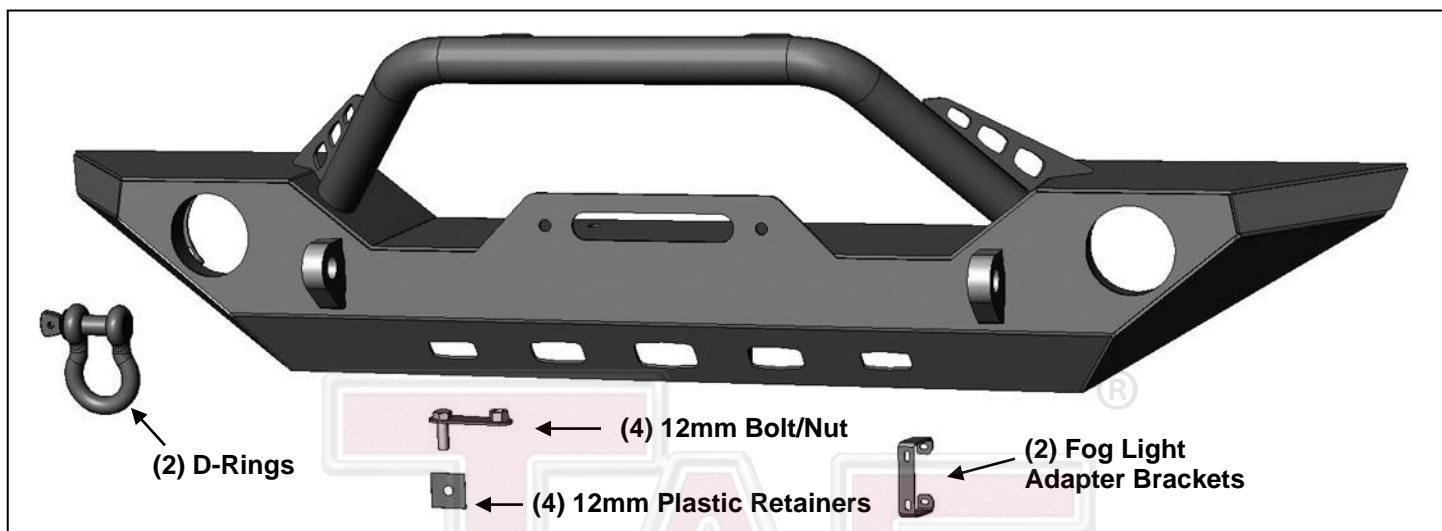

PROCEDURE:

REMOVE CONTENTS FROM BOX. VERIFY ALL PARTS ARE PRESENT. READ INSTRUCTIONS CAREFULLY BEFORE STARTING INSTALLATION. CUTTING MAY BE REQUIRED. ASSISTANCE IS RECOMMENDED. FACTORY 2-BOLT FOG LIGHT ASSEMBLY FROM OPTIONAL 2013-ON JK & JL OE STEEL WINCH BUMPER CANNOT BE INSTALLED.

1. Start under the front bumper of the vehicle and remove the plastic lower splash guard or skid plate, **(Figure 1)**. **NOTE:** Splash guard or skid plate cannot be reinstalled.
2. On models with factory fog lights, unplug wiring harness leading to the bumper before removing bumper.
3. With assistance, remove the front bumper hardware and bumper, **(Figures 2—4)**. Move the factory bumper to a stable surface.
4. Select (1) 12mm Bolt/Nut Plate and (1) 12mm Plastic Retainer, **(Figure 5)**. Insert the Bolt Plate down through the opening in the top of the inner bumper bracket welded to the back of the Bumper. Thread the Plastic Retainer onto the “Bolt” in the Bolt/Nut Plate to hold the Bolt/Nut Plate in position on the Bumper, **(Figures 6 & 7)**. Repeat this Step to install the (3) remaining 12mm Bolt/Nut Plates.
5. Remove fog lights and wiring harness from factory bumper.
6. **Determine fog light Installation:**
 - 4-bolt, evenly spaced mounting style (Excludes 2-bolt LED and halogen fog lights as supplied with 2013-on JK and JL models with OE steel winch compatible option bumper)**
 - a. Select (1) Adapter Bracket, **(Figure 8)**. Attach the Bracket to the inner mounting location with (2) 4mm Screws, (2) 4mm Lock Washers and (2) 4mm Flat Washers, **(Figures 8 & 9)**.
 - b. Attach the driver/left fog light assembly to the outer mounting plate and the inner Adapter Bracket with (4) 4mm Screws, (8) 4mm Flat Washers (4) 4mm Lock Washers and (4)

4mm Hex Nuts, (**Figures 10 & 11**). **IMPORTANT:** Do not overtighten fog light hardware or damage to the fog light may result.

2018-on JL Sport model w-1pc plastic bumper. Offset mounting style (1 screw to outside, 2 screws to inside of housing)

- a. Select the driver/left fog light assembly.
 - b. Attach the outer single tab on the light housing to the mounting plate with (1) 4mm Screw, (2) 4mm Flat Washers, (1) 4mm Lock Washer and (1) 4mm Hex Nut, (**Figure 12**). Leave hardware loose at this time.
 - c. Attach the inner side of the housing to the inner mounting plate with (3) 4mm Screws, (3) 4mm Lock Washers and (3) 4mm Flat Washers, (**Figures 12, 13A & 13B**). Tighten fog light mounting hardware. **IMPORTANT:** Do not overtighten fog light hardware or damage to the fog light may result.
7. Attach the wiring harness from factory bumper to the fog lights and Bumper.
 8. With assistance, line up the Bolt/Nut Plates in the back of the Bumper with top mounting holes in the bumper mounting plates on the end of the frame. Attach the Bolt/Nut Plates in the Bumper assembly to the frame with (4) 12mm Flat Washers, (4) 12mm Lock Washers and (4) 12mm Hex Nuts, (**Figure 14**). **IMPORTANT:** On some JK model years, the top inner mounting holes in the frame brackets may require drilling to clear the 12mm Bolt/Nut Plate. Use a 1/2" drill bit to open up the mounting holes for the 12mm hardware, (**Figure 3**). Leave hardware loose at this time.
 9. Rotate each Bolt on the (4) Bolt/Nut Plates to line up the Nut with the mounting hole in the Bumper and bumper bracket on the frame. Attach the "Nut" on the Bolt/Nut Plate to the frame with the included (4) 12mm Hex Bolts, (4) 12mm Lock Washers and (4) 12mm Flat Washers, (**Figures 14—16**). Do not fully tighten hardware at this time.
 10. Stand back from the vehicle and check to see that the Bumper is centered and level on the vehicle and adjust as required. Once properly aligned, fully tighten all hardware.
 11. Reattach the wiring harness for the fog lights to the main harness, if equipped.
 12. Do periodic inspections of the installation to make sure that all hardware is secure and tight.

To protect your investment, wax this product after installing. Regular waxing is recommended to add a protective layer over the finish. Do not use any type of polish or wax that may contain abrasives that could damage the finish. Mild soap may be used to clean the Front Bumper.

Driver/left Side Installation Pictured

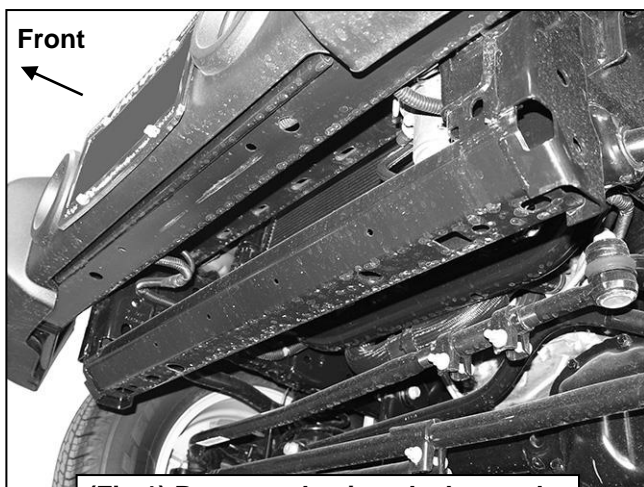

(Fig 1) Remove plastic splash guard or skid plate from bottom of bumper

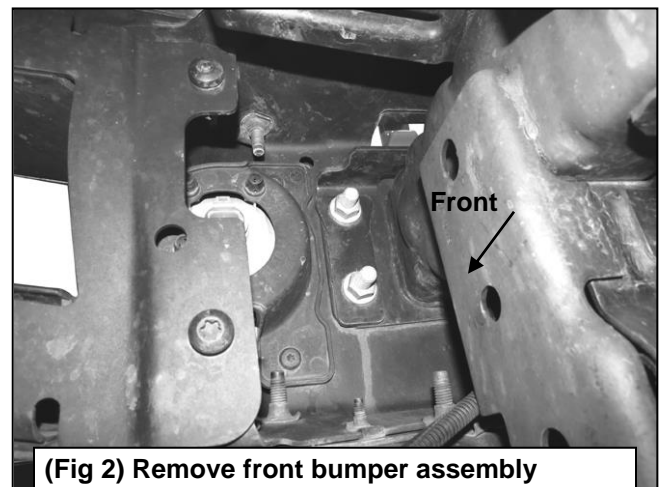

(Fig 2) Remove front bumper assembly (driver side JK outer bumper bolts pictured)

Driver/left Side Installation Pictured



(Fig 3) Front Bumper and splash guard removed from 2007-18 JK model pictured



(Fig 4) Front Bumper and splash guard removed from 2018-on JL model pictured

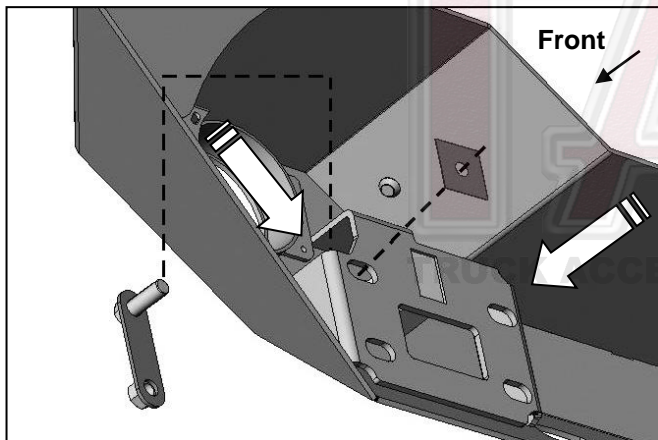

(Fig 5) Insert 12mm Bolt/Nut Plate down into opening in back of bumper bracket. Push Bolt out through top mounting hole

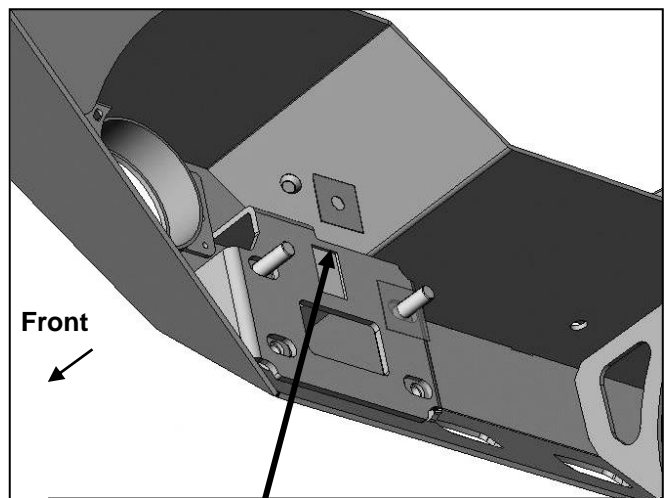

(Fig 6) Thread 12mm Plastic Retainer onto Bolt to hold Bolt/Nut Plate in position

Driver/left Side Installation Pictured

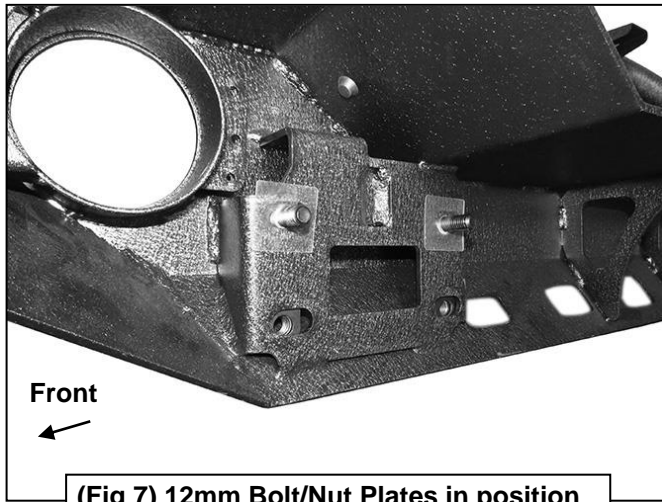

- (2) 4mm x 15mm Button Head Screws
- (2) 4mm Lock Washers
- (2) 4mm Flat Washers

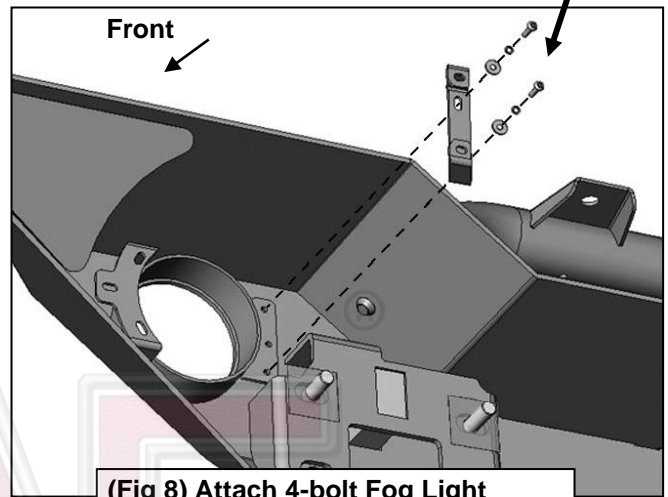

- (2) 4mm x 15mm Button Head Screws
- (2) 4mm Lock Washers
- (2) 4mm Flat Washers

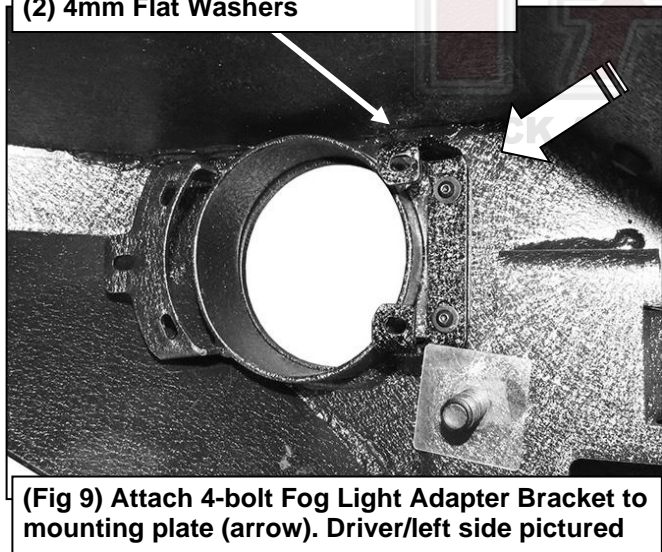

- (4) 4mm x 15mm Button Head Screws
- (8) 4mm Flat Washers
- (4) 4mm Lock Washers
- (4) 4mm Hex Nuts

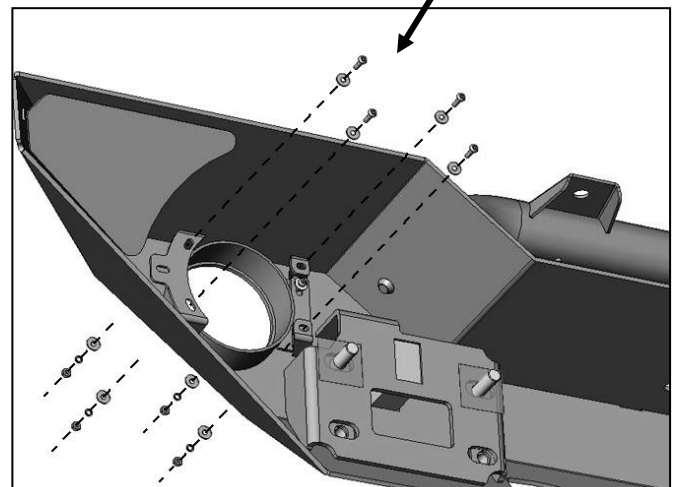

Driver/left Side Installation Pictured

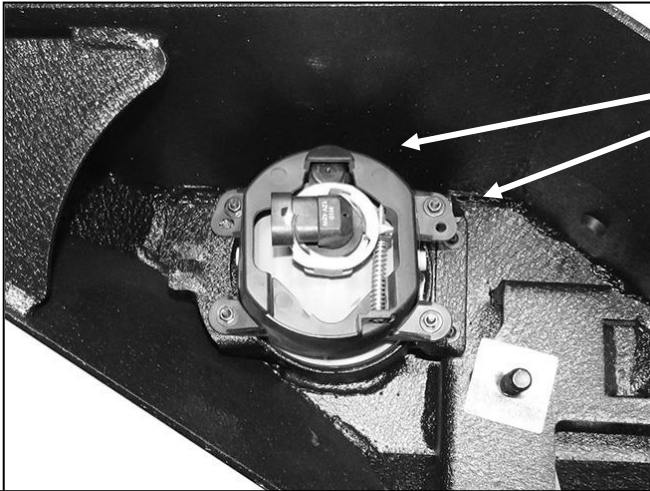

- (4) 4mm x 15mm Button Head Screws
- (8) 4mm Flat Washers
- (4) 4mm Lock Washers
- (4) 4mm Hex Nuts

(Fig 11) Attach 4-bolt Fog Light to Adapter Bracket and mounting plate. Driver/left side pictured

- (3) 4mm x 15mm Button Head Screws
- (3) 4mm Lock Washers
- (3) 4mm Flat Washers

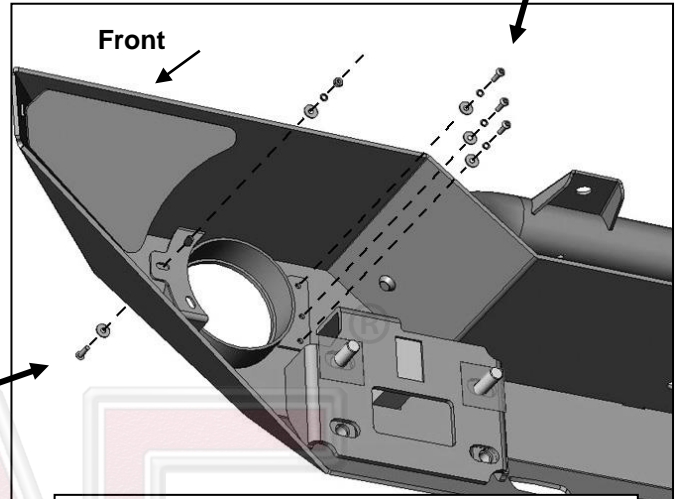

(Fig 12) Attach offset style fog light to mounting plates. Driver/left side illustrated

- 4mm x 15mm Button Head Screw
- (2) 4mm Flat Washers
- 4mm Lock Washer
- 4mm Hex Nut

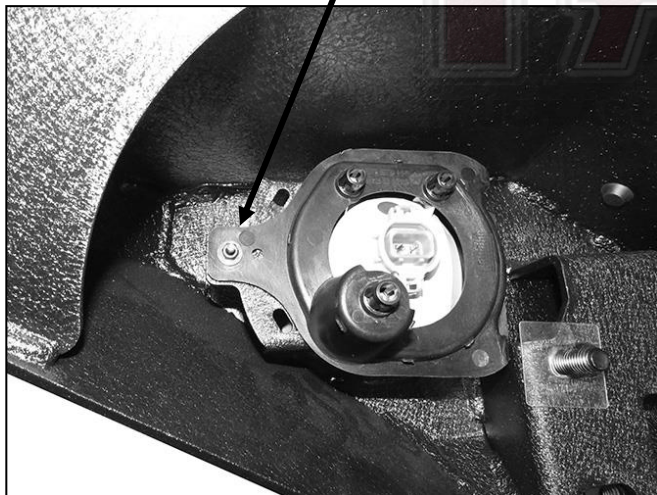

(Fig 13A) Attach offset style fog light from JL Sport model w-1pc plastic bumper, directly to mounting plates. Driver/left side pictured

- (3) 4mm x 15mm Button Head Screws
- (3) 4mm Lock Washers
- (3) 4mm Flat Washers



(Fig 13B) Attach offset style fog light directly to mounting plates. Driver/left side pictured

Driver/Left Side Installation Pictured

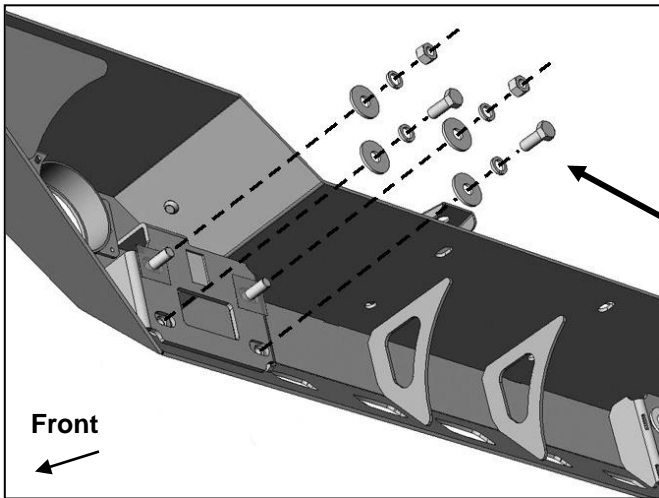

- (2) 12mm x 30mm Hex Bolts
- (4) 12mm Flat Washers
- (4) 12mm Lock Washers
- (2) 12mm Hex Nuts

(Fig 14) Attach Bumper assembly to bumper mounting plates on ends of frame



(Fig 15) Bumper installed on JL. Driver/left outer installation pictured from behind Bumper

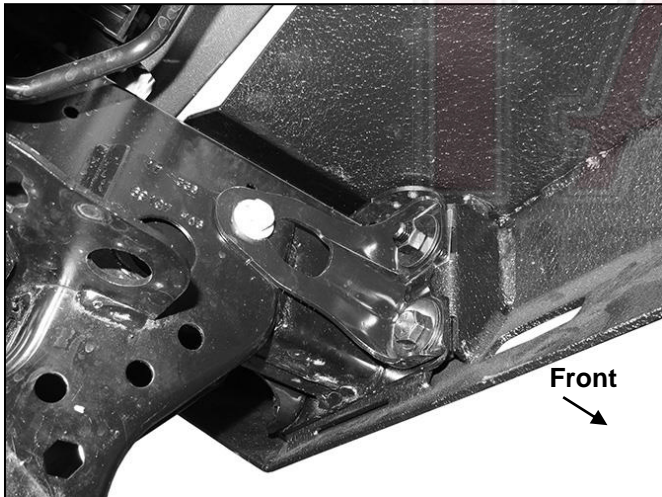

(Fig 16) Bumper installed on JL. Driver/left inner installation pictured from behind Bumper

