



## **INSTALLATION INSTRUCTIONS**

**5" OVAL BENT END SIDEBARS**

**09-18 DODGE RAM 1500 CREW CAB (INCL. 19-23 RAM 1500 CLASSIC)**

**10-23 DODGE RAM 25-5500 CREW CAB (INCL. CHASSIS CAB DIESEL MODELS)**

**PART# 5S-D1012B**

**TAC**  
TRUCK ACCESSORIES COMPANY

**PARTS LIST:**

1	Driver/Left Sidebar	4	10mm Lock Washers
1	Passenger/Right Sidebar	4	10mm Hex Nuts
1	Driver/Left Front Mounting Bracket	4	10mm Plastic Retainers
1	Passenger/Right Front Mounting Bracket	10	8mm x 30mm Hex Bolts
1	Driver/Left Center Mounting Bracket	2	8mm x 25mm Hex Bolts
1	Passenger/Right Center Mounting Bracket	12	8mm x 25mm Combo Bolts
1	Driver/Left Rear Mounting Bracket	2	8mm Bolt Plates with Handle
1	Passenger/Right Rear Mounting Bracket	20	8mm x 24mm OD x 2mm Flat Washers
2	Driver/Left Front Support Brackets	4	8mm Lock Washers
2	Passenger/Right Front Support Brackets	2	8mm Hex Nuts
1	Driver/Left Rear Support Bracket	8	8mm Nylon Lock Nuts
1	Passenger/Right Rear Support Bracket	2	8mm Plastic Retainers
2	10mm Bolt Plates	8	6mm x 25mm Hex Bolts
2	10mm Bolt/Nut Plates	16	6mm x 22mm OD x 2mm Flat Washers
4	10mm x 30mm OD x 2.5mm Flat Washers	8	6mm Nylon Lock Nuts

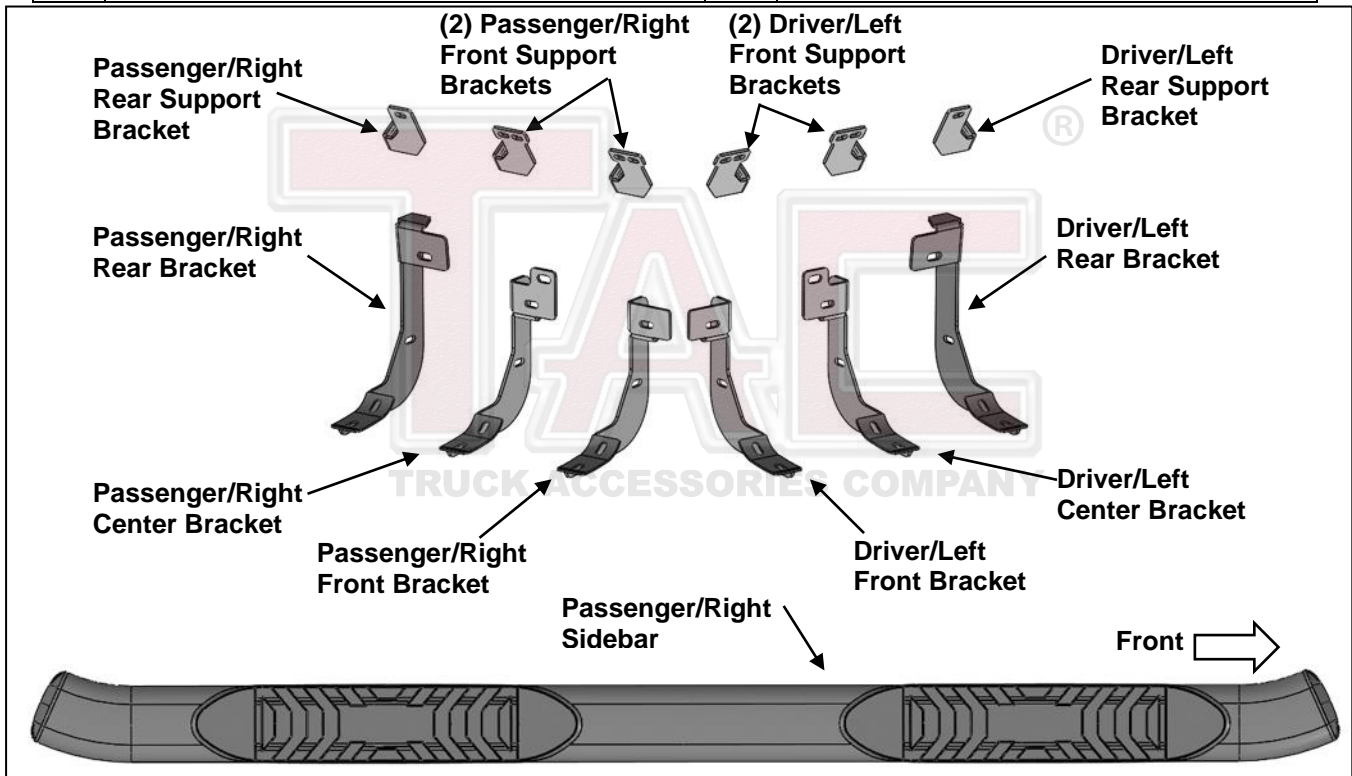

**PROCEDURE:**

1. REMOVE CONTENTS FROM BOX. VERIFY ALL PARTS ARE PRESENT. READ INSTRUCTIONS CAREFULLY BEFORE STARTING INSTALLATION. DRILLING MAY BE REQUIRED.
2. Starting at the Passenger/Right front side of the vehicle, remove the sealing tape covering the factory holes in the side of the inner panel, (Figure 1).
3. Determine the correct procedure to attach the driver/left side Front Bracket for your model/year:
 

**Models without factory threaded inserts in body panel, (see Figure 1):**

  - a. Select (1) 8mm Bolt Plate with Handle, (Figure 2). Insert the threads of the Bolt Plate into the large hole and out the rear hex shaped hole in the rocker panel, (Figures 1 & 2).
  - b. Thread (1) 8mm Plastic Retainer onto the threaded end and down tight against the body panel, (Figure 2). **NOTE:** The Plastic Retainer is designed to keep the Bolt Plate from falling into the body panel and to aid in Bracket installation.

- c. Select the Passenger/Right Front Mounting Bracket. Attach the Bracket to the threads on the Bolt Plate with (1) 8mm Flat Washer, (1) 8mm Lock Washer and (1) 8mm Hex Nut, **(Figure 2)**. Do not tighten hardware

**Models with factory threaded inserts, (see Figure 12):**

- a. Attach the Passenger/Right Front Mounting Bracket to the rear threaded hole with (1) 8mm x 30mm Hex Bolts, (1) 8mm Lock Washers and (1) 8mm Flat Washers, **(Figures 12 & 13)**. Do not tighten hardware.
- b. Repeat the previous **Step** for the center mounting location, (Do not use the 10mm Bolt/Nut Plates).
4. Next, select (1) Passenger/Right Front Support Bracket. Attach the Bracket to the back of the pinch weld with (2) 6mm Button Head Bolts, (4) 6mm x 18mm Flat Washers and (2) 6mm Nylon Lock Nuts, **(Figure 3)**. Do not tighten hardware. **IMPORTANT:** 2009-12 models not equipped with factory holes will require drilling through the pinch weld to fully attach Bracket. Do not drill through pinch weld at this time, **(see Step 10)**.
5. Attach the Support Bracket to the Mounting Bracket with (1) 8mm x 30mm Hex Bolt, (2) 8mm flat Washers and (1) 8mm Nylon Lock Nut, **(Figures 4 & 5)**. Do not tighten hardware.
6. Move along the side of the body panel to the center mounting location, **(Figure 6)**. Select (1) 10mm Bolt/Nut Plate. Hold the threads of the Bolt/Nut Plate and insert the threaded hole into the large hole in the center location. Thread (1) 10mm Plastic Retainer onto the threaded end and down tight against the body panel, **(Figure 7)**. Select the Passenger/Right Center Mounting Bracket. Attach the top hole in the Bracket to the threads of the Bolt/Nut Plate with (1) 10mm Flat Washer, (1) 10mm Lock Washer and (1) 10mm Hex Nut, **(Figure 7)**. Attach the bottom hole in the top of the Bracket to the threaded hole in the Bolt/Nut Plate with (1) 8mm Hex Bolt, (1) 8mm Lock Washer and (1) 8mm Flat Washer, **(Figure 7)**. Do not tighten hardware. **NOTE:** If threaded holes are equipped with the vehicle, refer to **Step 3**. Repeat **Step 5** to attach (1) Passenger/Right Front Support Bracket.
7. Move to the rear location, **(Figure 8)**. Select (1) 10mm Bolt Plate. Insert the Bolt Plate into the hole in the rear location. Thread (1) 10mm Plastic Retainer onto the threaded end and down tight against the body panel, **(Figures 8 & 9)**. Select the Passenger/Right Rear Mounting Bracket. Attach the Bracket to the Bolt Plate with (1) 10mm Flat Washer, (1) 10mm Lock Washer and (1) 10mm Hex Nut, **(Figures 9 & 10)**. Do not tighten hardware.
8. Select the Passenger/Right Rear Support Bracket. Attach the Support Bracket to the Mounting Bracket with (1) 8mm x 30mm Hex Bolt, (2) 8mm flat Washers and (1) 8mm Nylon Lock Nut. Do not tighten hardware. Place the top of the Support Bracket onto the back of the pinch trim. Mark the location of the slot. **NOTE:** Do not mark too closely to the edge of the pinch trim or damage to the vehicle may result. Refer to **Step 10** for drilling a 3/8inch hole. Attach the Support Bracket to the pinch trim with (1) 8mm Hex Bolt, (2) 8mm Flat Washers and (1) 8mm Nylon Lock Nut, **(Figure 11)**. Do not tighten hardware.
9. Once all Brackets have been fully installed, select the Passenger/Right Sidebar. Attach the Sidebar to the Mounting Brackets with (6) 8mm Combo Bolts, **(Figure 14)**. Do not tighten hardware.
10. Properly level and adjust the Sidebar and fully tighten all hardware.  
**2009-12 models requiring drilling to attach Brackets to pinch weld:**
  - a. Level the Sidebar to the vehicle. Make sure all (3) Brackets are tight against the bottom of the body panel and tighten all mounting hardware.
  - b. Mark the location of the slots onto the pinch weld.
  - c. Temporarily remove the Sidebar and the (3) Mounting Brackets. Drill (2) 1/4" holes through the pinch weld for each Bracket. **IMPORTANT:** Do not drill too close to the bottom edge of the pinch weld. Drill the holes in the center of the marked slots.
  - d. Repeat **Step 4** to attach the Brackets to the drilled holes in the pinch weld. Check for level then fully tighten all hardware.
11. Repeat **Steps 2—10** to attach the Driver/Left Sidebar.
12. Do periodic inspections to the installation to make sure that all hardware is secure and tight.

**To protect your investment** Do not use any type of polish or wax that may contain abrasives that could damage the finish. Mild soap may be used to clean the Sidebar.

### Passenger/Right Side Installation Pictured

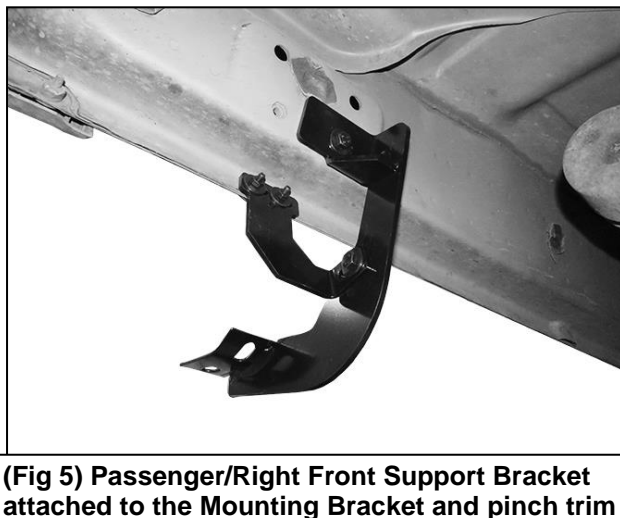
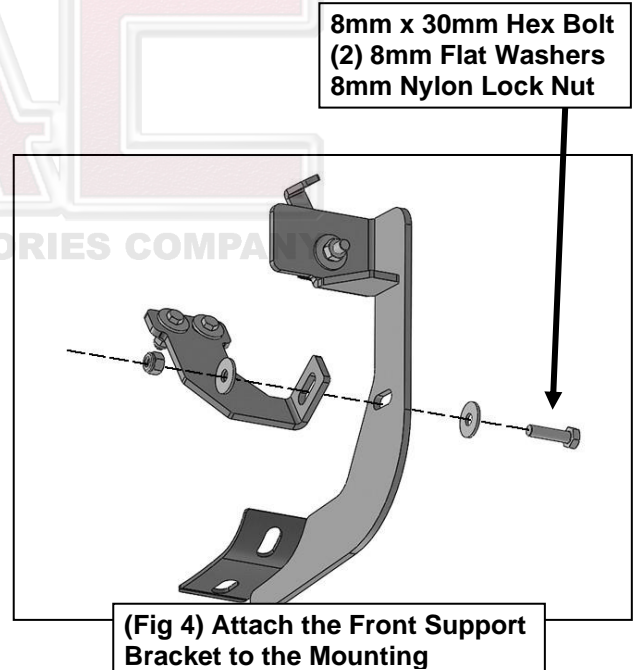
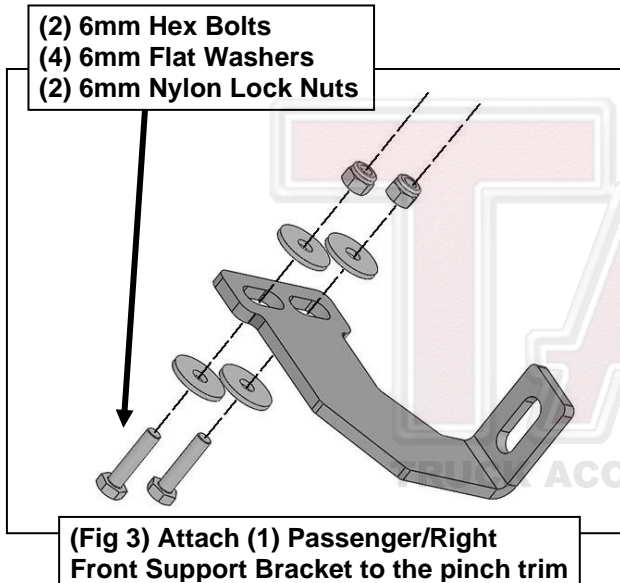
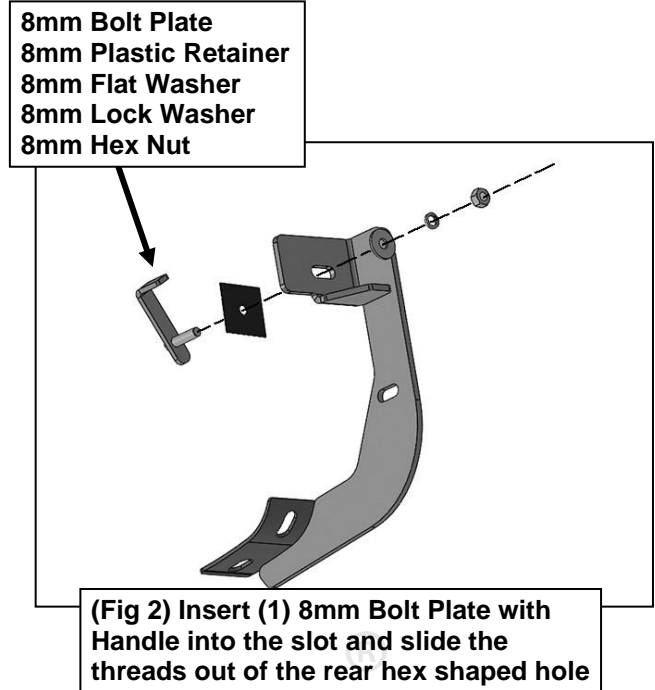
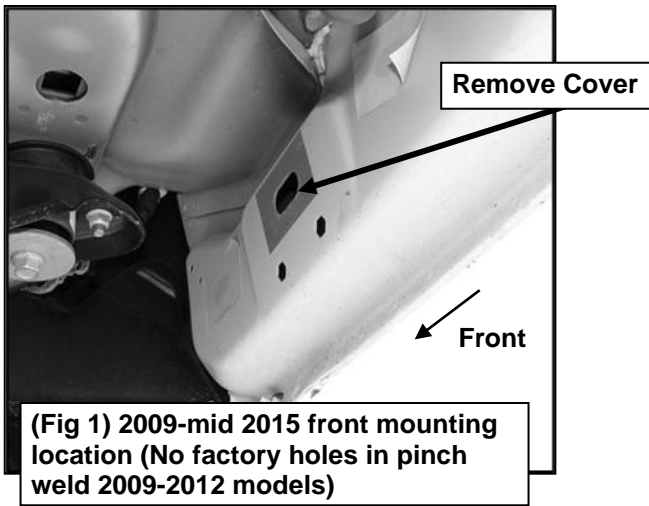

**Passenger/Right Side Installation Pictured**



**(Fig 6)** Insert (1) 10mm Bolt/Nut Plate into the upper slot and line the threaded nut up to the rear hex hole, Thread (1) 10mm Plastic Retainer over the threads to hold it in place

- 10mm Bolt/Nut Plate
- 10mm Plastic Retainer
- 10mm Flat Washer
- 10mm Lock Washer
- 10mm Hex Nut

- 8mm Hex Bolt
- 8mm Lock Washer
- 8mm Flat Washer

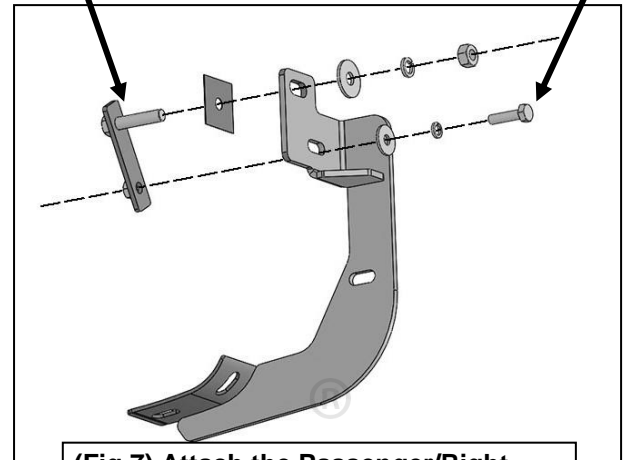

**(Fig 7)** Attach the Passenger/Right Mounting Bracket to the Bolt/Nut Plate

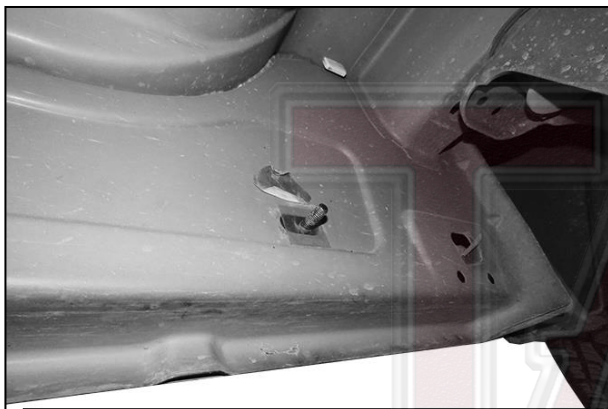

**(Fig 8)** Remove the cover over the large slot in the rear location, insert (1) 10mm Bolt Plate into the slot, Thread (1) 10mm Plastic Retainer to hold the Bolt Plate in place

- 10mm Bolt Plate
- 10mm Plastic Retainer
- 10mm Flat Washer
- 10mm Lock Washer
- 10mm Hex Nut

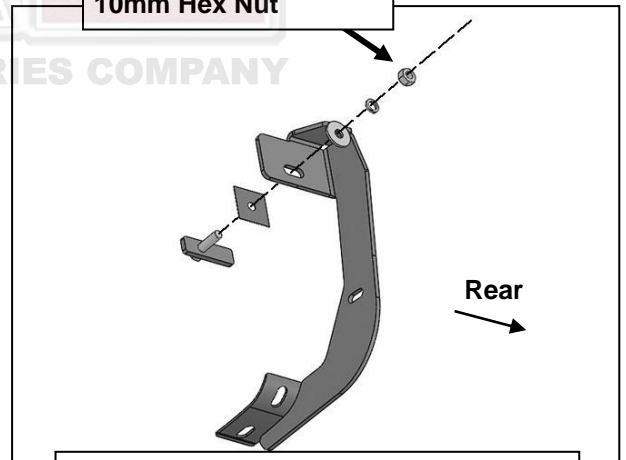

**(Fig 9)** Attach the Passenger/Right Rear Mounting Bracket to the Bolt Plate



**(Fig 10)** Attach the Passenger/Right Rear Support Bracket to the Rear Mounting Bracket. Mark the location of the upper slot in the Support Bracket on the pinch trim for drilling. Use a 1/4inch drill bit, (drill bit not included)

**NOTE:** Do not drill too closely to the edge of the pinch trim or damage to the vehicle may result

### Passenger/Right Side Installation Pictured

8mm x 25mm Hex Bolt  
(2) 8mm Flat Washer  
8mm Nylon Lock Nut

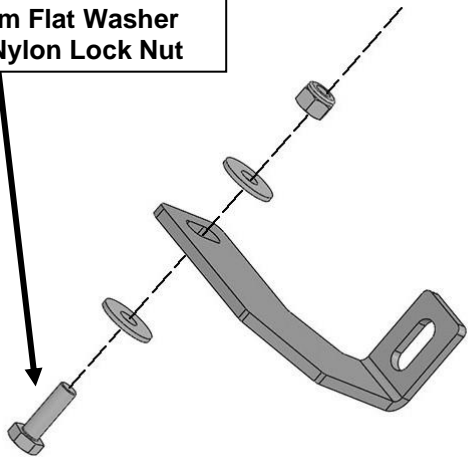

(Fig 11) Attach the Passenger Right Rear Support Bracket to the pinch trim

**IMPORTANT: 2009-2012 models without holes in pinch weld will require drilling 1/4" holes through pinch weld to attach the bracket. Do complete installation of Sidebars first, level Sidebar before drilling holes for bracket.**

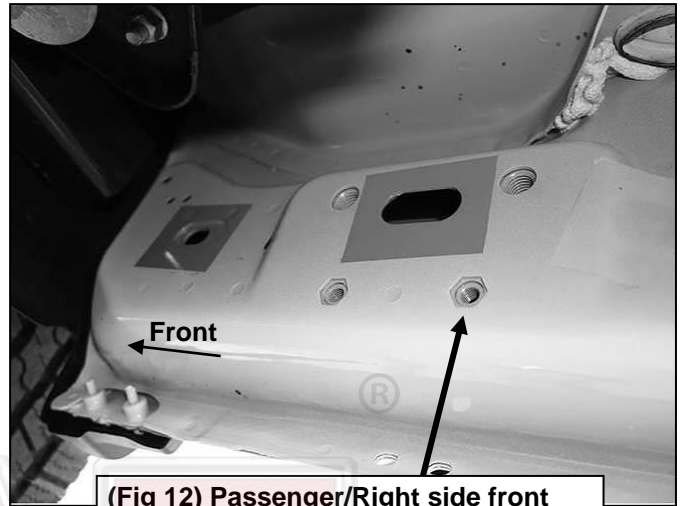

(Fig 12) Passenger/Right side front mid 2015-on (example of models with factory installed threaded inserts)

8mm Hex Bolt  
8mm Lock Washer  
8mm Flat Washer

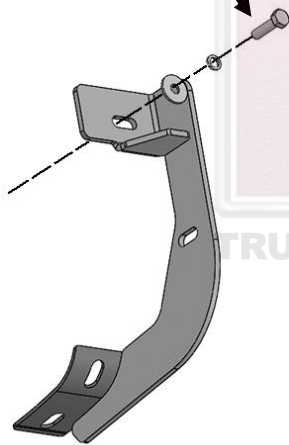

(Fig 13) Attach the Passenger/Right Front Mounting Bracket to the rear threaded hole in the front location

(2) 8mm Combo Bolts

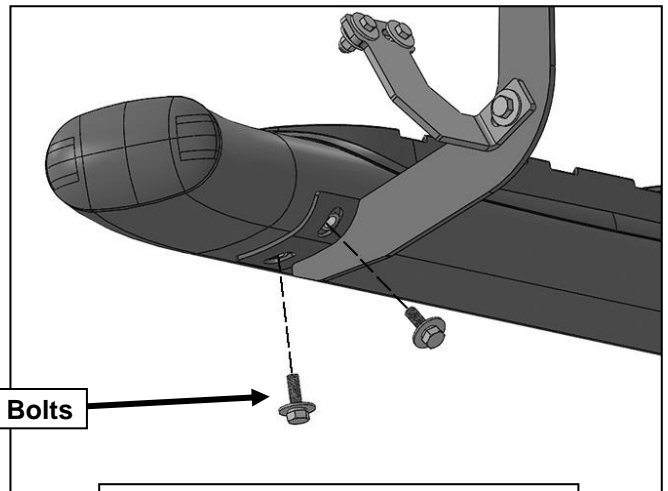

(Fig 14) Attach the Passenger/Right Sidebar to the Mounting Brackets