



INSTALLATION INSTRUCTIONS

4" OVAL STRAIGHT SIDEBARS

2009-2018 DODGE RAM 1500 (INCL. 19-23 RAM 1500 CLASSIC)

2010-2024 DODGE RAM 25-5500 REGULAR CAB

PART# 4S-D1092-1

TRUCK ACCESSORIES COMPANY

PARTS LIST:

1	Driver/Left Sidebar	8	8mm-1.25 x 25mm Combination Hex Bolts
1	Passenger/Right Sidebar	16	8mm x 24mm x 2mm Flat Washers
2	Driver/left Mounting Brackets	8	8mm Lock Washers
2	Passenger/passenger Mounting Brackets	4	8mm Hex Nuts
2	Driver/left Support Brackets	4	8mm Nylon Lock Nuts
2	Passenger/right Support Brackets	8	6mm x 25mm Hex Bolts
4	8mm Nut/Bolt Plates	16	6mm x 22mm x 2mm Flat Washers
4	8mm Plastic Retainers	8	6mm Nylon Lock Nuts
12	8mm-1.25 x 30 Hex Bolts		

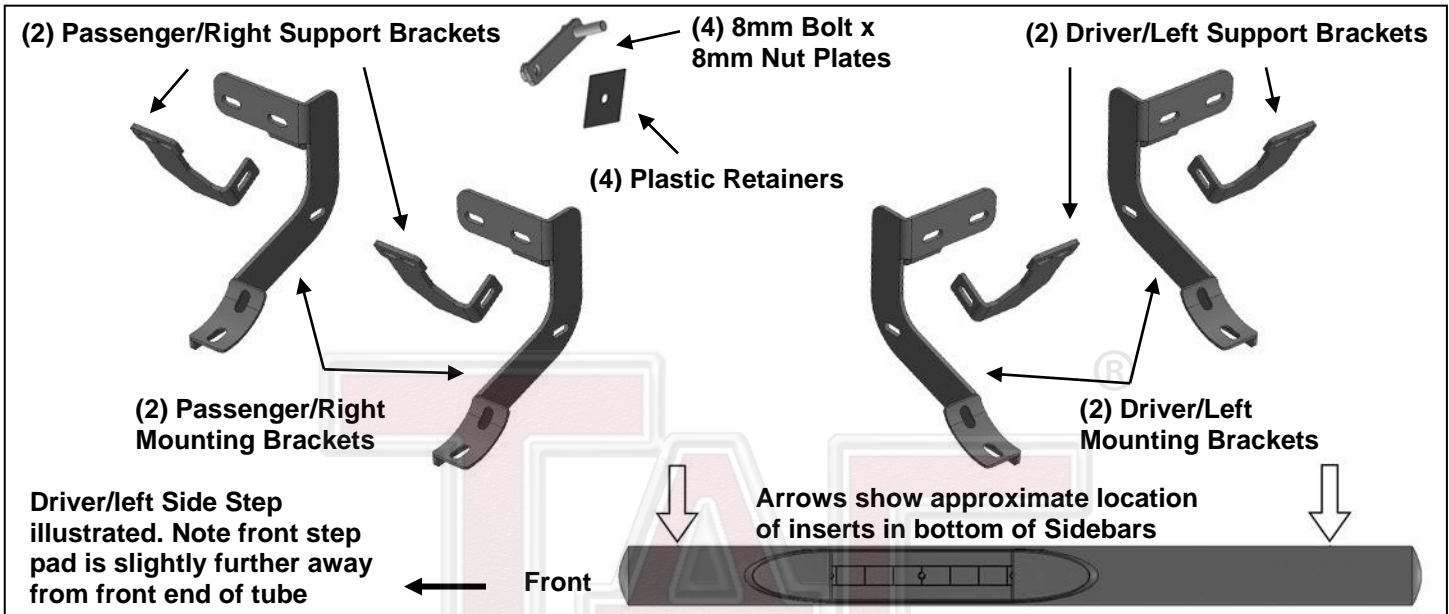

PROCEDURE:

1. REMOVE CONTENTS FROM BOX. VERIFY ALL PARTS ARE PRESENT. READ INSTRUCTIONS CAREFULLY BEFORE STARTING INSTALLATION. DRILLING MAY BE REQUIRED.
2. Starting at the driver side-front of the vehicle, remove the sealing tape covering the factory holes in the side of the inner panel, **(Figure 1)**.
3. Determine the correct procedure to attach the driver side front Bracket for your model/year:

Models without factory threaded inserts in body panel:

 - a. Partially thread an 8mm Hex Bolt into the threaded end of an 8mm Bolt and Nut Plate, **(Figure 2)**. Thread the Hex Bolt in until it is flush with the welded nut, **(Figure 3)**. Use the Hex Bolt as a handle and insert the Bolt and Nut Plate into the oval hole, **(Figure 4)**.
 - b. Feed the threaded bolt on the Bolt Plate through one of the hex shaped factory holes.
 - c. Thread (1) 8mm Plastic Retainer onto the threaded end and down tight against the body panel, **(Figure 5)**. **NOTE:** The Plastic Retainer is designed to keep the Bolt/Nut Plate from falling into the body panel and to aid in Bracket installation.
 - d. Select a driver side Mounting Bracket, **(Figure 6)**. Attach the Bracket to the threaded end of the Bolt Plate with (1) 8mm Flat Washer, (1) 8mm Lock Washer and (1) 8mm Hex Nut, **(Figure 7)**. Do not tighten at this time.
 - e. Remove the 8mm Hex Bolt from the nut on the Bolt Plate from **Step 3a**. Rotate the Bolt on the Bolt Plate until the threaded nut lines up with the remaining hole in the Mounting Bracket and body panel, **(Figures 7 & 8)**. Attach the Bracket to the Nut Plate with (1) 8mm x 30mm Hex Bolt, (1) 8mm Lock Washer and (1) 8mm Flat Washer, **(Figure 8)**. Do not fully tighten hardware at this time.

Models with factory threaded inserts:

 - a. Attach the driver side Front Bracket directly to the threaded inserts with (2) 8mm x 30mm Hex Bolts, (2) 8mm Lock Washers and (2) 8mm Flat Washer, **(Figures 9 & 10)**. Leave hardware loose.

4. Next, select a driver side Support Bracket. Attach the Bracket to the back of the front Bracket with (1) 8mm x 30mm Hex Bolt, (2) 8mm Flat Washers and (1) 8mm Nylon Lock Nut, **(Figure 11)**. Rotate the Support Bracket to the back of the pinch weld. Line up the slots in the top of the Support Bracket with the (2) factory holes in the pinch weld. Attach the Bracket to the back of the pinch weld with (2) 6mm x 25mm Hex Bolts, (4) 6mm Flat Washers and (2) 6mm Nylon Lock Nuts, **(Figure 12)**. Do not fully tighten hardware at this time. **IMPORTANT:** 2009-10 models are not equipped with factory holes and will require drilling through the pinch weld to attach the Support Bracket. Do not drill through pinch weld at this time, **(see Step 7)**.
5. Move along the side of the body panel to the rear location, **(Figure 13)**. Repeat **Steps 2—4** to install the rear Brackets, **(Figure 14)**. **NOTE:** The cradles on the front and rear Brackets must all face forward.
6. Select the driver/left Sidebar. Carefully position the Sidebar onto the (2) Mounting Brackets. **IMPORTANT:** Do not slide, (front to back or rotate), the Sidebar on the Brackets or damage to the finish on the Sidebar may result. Attach the Sidebar to the Brackets with (4) 8mm Combination Hex Bolts, **(Figures 15 & 16)**. Do not fully tighten at this time.
7. Properly level and adjust the Sidebar and fully tighten all hardware.
2009-10 models requiring drilling for driver side Support Brackets:
 - a. Make sure the Sidebar is level to the vehicle. Adjust and tighten all mounting hardware.
 - b. Line up the slots on the Support Brackets with the back of the pinch weld. Mark the location of the slots onto the pinch weld.
 - c. Drill (2) 1/4" holes through the pinch weld for each Support Bracket. **IMPORTANT:** Do not drill too close to the bottom edge of the pinch weld. Adjust the Brackets as necessary to move the slots up the body panel away from the edge. Drill the holes toward the outside of the marked slots.
 - d. Attach each Support Bracket to the pinch weld with (2) 6mm Hex Bolts, (4) 6mm Flat Washers and (2) 6mm Nylon Lock Nuts, **(Figures 14—16)**. Check the Sidebar for level and tighten all hardware.
8. Move to the passenger side of the vehicle. Remove tape covering front and rear locations. Repeat **Steps 2—7** for passenger side installation.
9. Do periodic inspections to the installation to make sure that all hardware is secure and tight.

To protect your investment, wax this product after installing. Regular waxing is recommended to add a protective layer over the finish. Do not use any type of polish or wax that may contain abrasives that could damage the finish.

For stainless steel: Aluminum polish may be used to polish small scratches and scuffs on the finish. Mild soap may be used also to clean the Sidebars.

For gloss black finishes: Mild soap may be used to clean the Sidebars.

Driver Side Installation Pictured

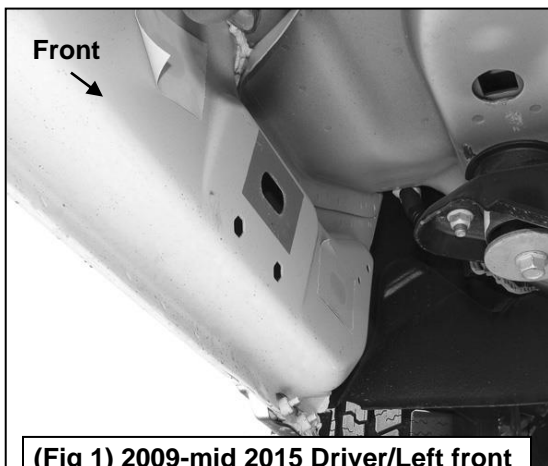

(Fig 1) 2009-mid 2015 Driver/Left front mounting location (No factory holes in pinch weld on 2009-2011 models)

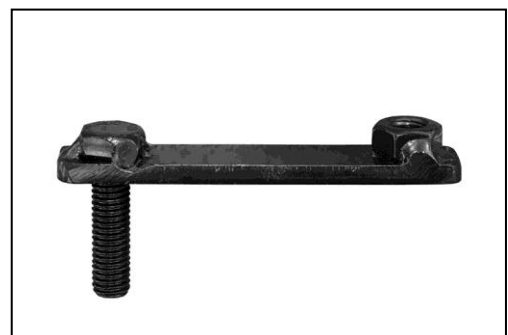

(Fig 2) 8mm Bolt-8mm Nut Plate, NOTE: 8mm Bolt-Nut Plate is not required on models with threaded inserts

Driver Side Installation Pictured

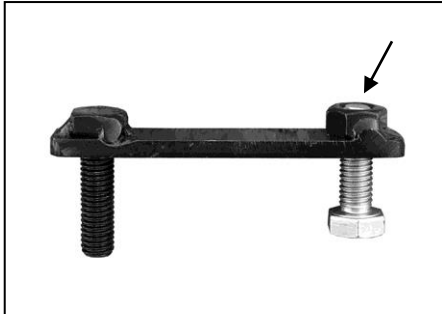

(Fig 3) Thread (1) 8mm Hex Bolt into the nut on the plate. Stop when bolt reaches end of nut as pictured

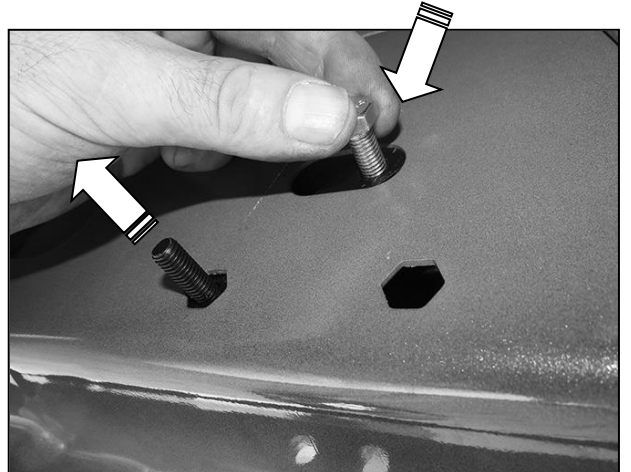

(Fig 4) Use the loose Hex Bolt as a handle. Insert the Bolt Plate into the oval hole and feed the threaded end out either factory hex shaped hole. **IMPORTANT:** Do not let go of the hex bolt until after Plastic Retainer has been threaded onto bolt (Fig 5)

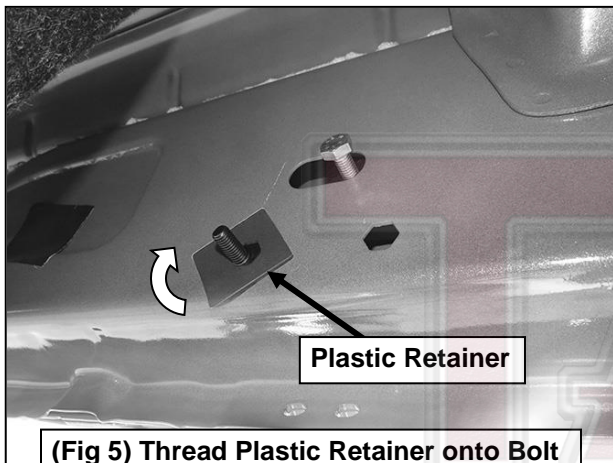

Plastic Retainer

(Fig 5) Thread Plastic Retainer onto Bolt Plate to hold Bolt Plate in position.

Remove Hex Bolt, rotate Bolt/Nut Plate to line up threaded nut with body panel and Mounting Bracket (see arrow)



(Fig 6) Driver side Brackets

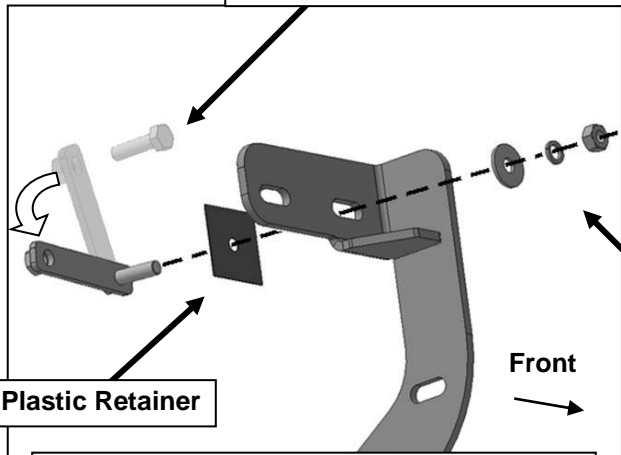

8mm Flat Washer
8mm Lock Washer
8mm Hex Nut

Plastic Retainer

Front

(Fig 7) Attach Bracket to Bolt on Bolt Plate

Driver Side Installation Pictured

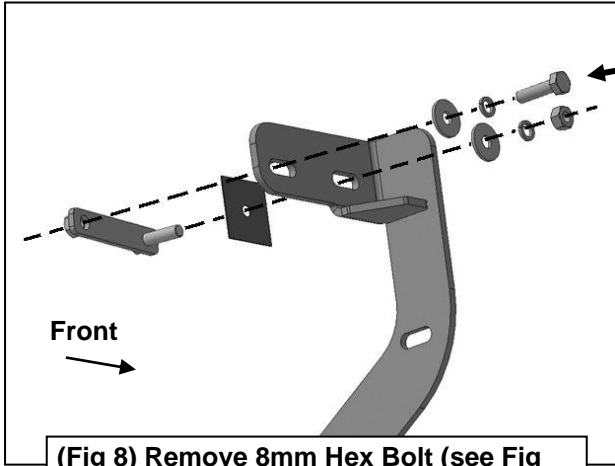

- 8mm Hex Bolt
- 8mm Lock Washer
- 8mm Flat Washer

(Fig 8) Remove 8mm Hex Bolt (see Fig 3). Rotate Bolt Plate to line up with remaining factory hex shaped hole.

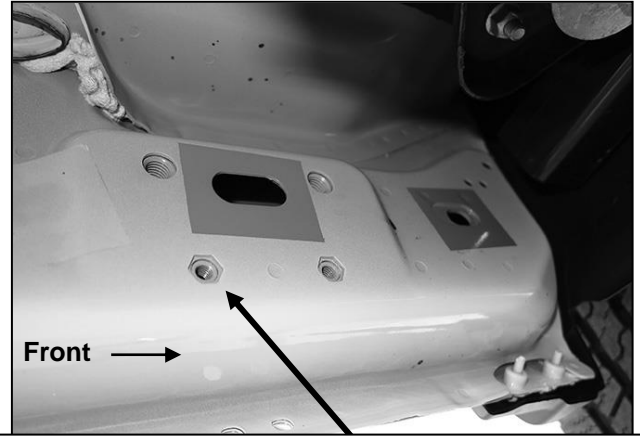

(Fig 9) Driver side front mid 2015-on, an example of models with factory installed threaded inserts

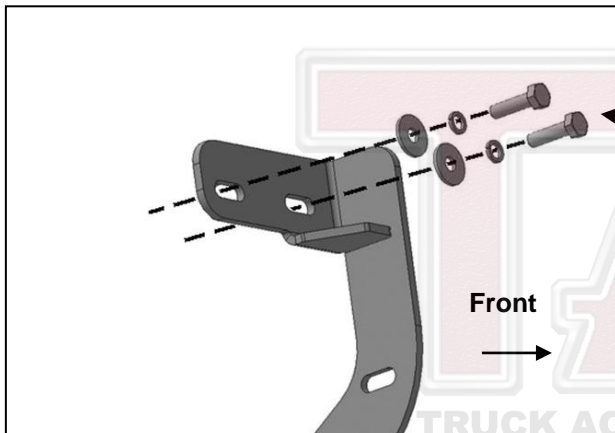

- (2) 8mm Hex Bolts
- (2) 8mm Lock Washers
- (2) 8mm Flat Washers

- 8mm Hex Bolt
- (2) 8mm Flat Washers
- 8mm Nylon Lock Nut

(Fig 10) Driver side front-models with factory installed threaded inserts. Bolt Plate not required

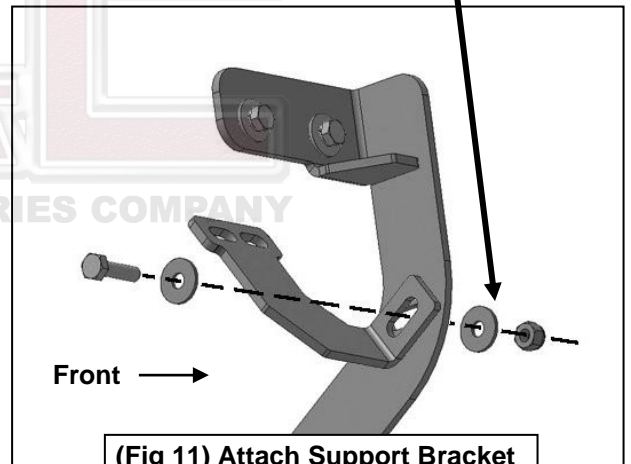

(Fig 11) Attach Support Bracket to back of Mounting Bracket

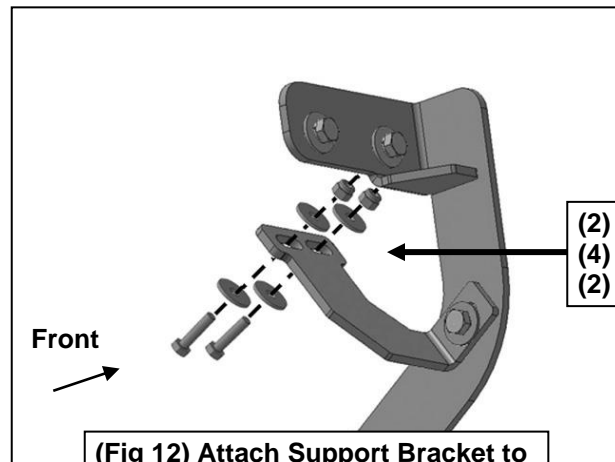

- (2) 6mm Hex Bolts
- (4) 6mm Flat Washers
- (2) 6mm Nylon Lock Nuts

(Fig 12) Attach Support Bracket to back of pinch weld (models with factory holes in pinch weld only)

IMPORTANT: 2009-2010 models without holes in pinch weld will require drilling 1/4" holes through pinch weld to attach driver side front support bracket. Do complete installation of sidebars first, level sidebar before drilling holes for support bracket.

Driver Side Installation Pictured

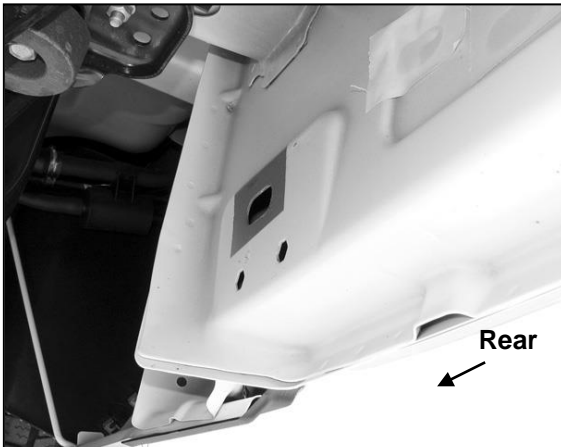

(Fig 13) Driver/Left rear mounting location

IMPORTANT: 2009-2010 models without holes in pinch weld will require drilling 1/4" holes through pinch weld to attach driver side front support bracket. Do complete installation of sidebars first, level sidebar before drilling holes for support bracket.



(Fig 14) Driver/Left rear Brackets installed

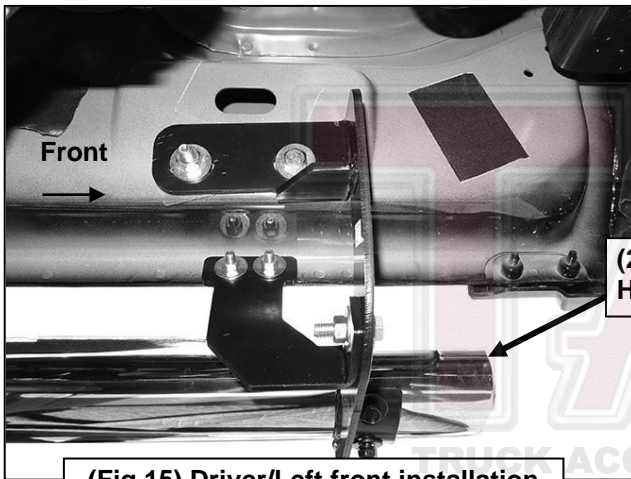

(Fig 15) Driver/Left front installation



(Fig 16) Driver/Left rear installation



Installation Complete