



# **INSTALLATION INSTRUCTIONS**

**SIDE BAR**

**09-20 DODGE JOURNEY**

**PART#221800**

**TRUCK ACCESSORIES COMPANY**

1	Driver/Left Sidebar	14	12mm ID x 24mm OD x 2.5mm Flat Washers
1	Passenger/Right Sidebar	10	12mm Lock Washers
1	Driver/Left Front Frame Mounting Bracket	8	12mm Hex Nuts
1	Passenger/Right Front Frame Mounting Bracket	4	10mm x 35mm Hex Bolts
1	Driver/Left Front Sidebar Mounting Bracket	8	10mm ID x20mm OD x 2mm Flat Washers
1	Passenger/Right Front Sidebar Mounting Bracket	4	10mm Lock Washers
1	Driver/Left Rear Sidebar Mounting Bracket	4	10mm Hex Nuts
1	Passenger/Right Rear Sidebar Mounting Bracket	8	8mm x 25mm Hex Bolts
2	Support Bracket Tabs ( <b>fits L-Front &amp; R-Rear</b> )	8	8mm x 24mm OD x2mm Flat Washers
2	Support Bracket Tabs ( <b>fits R-Front &amp; L-Rear</b> )	8	8mm Lock Washers
2	12mm Nut Plates	4	6mm x 35mm Hex Bolts
2	12mm x 35mm Short Bolt Plates	8	6mm ID x 18mm OD x 1.6mm Flat Washers
2	12mm x 95mm Long Bolt Plates	4	6mm Nylock Nuts
6	12mm x 35mm Hex Bolts		

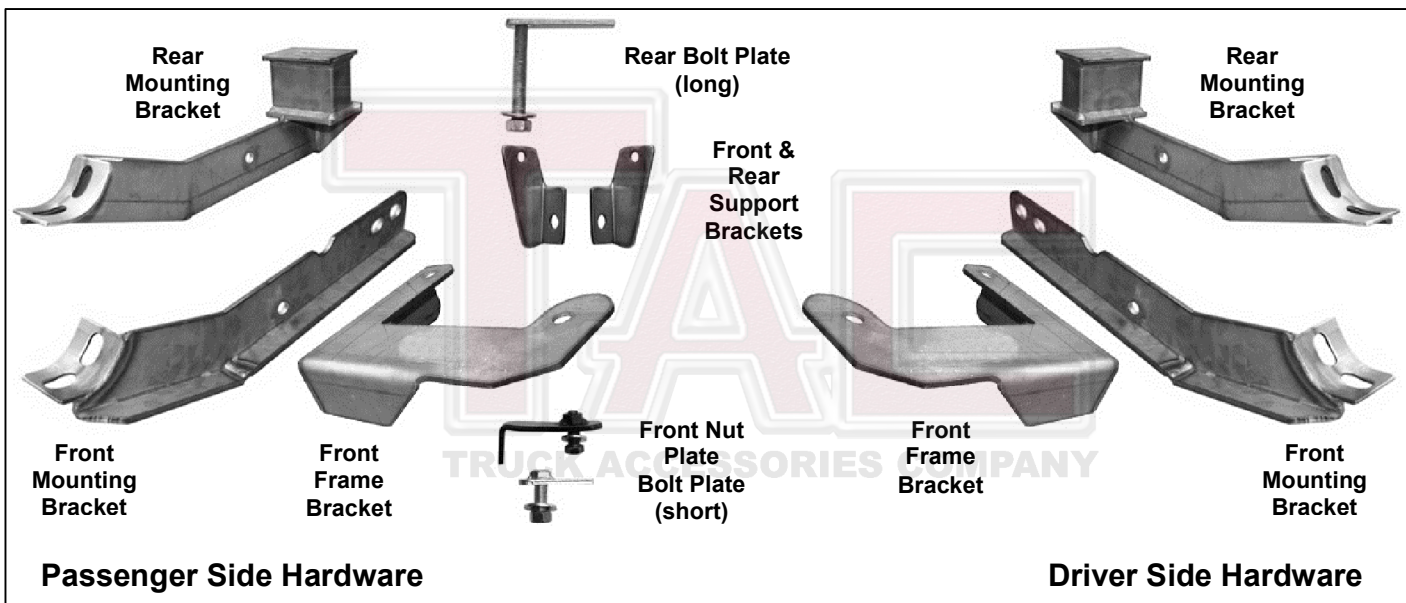

**PROCEDURE:**

- 1. REMOVE CONTENTS FROM BOX. VERIFY ALL PARTS ARE PRESENT. READ INSTRUCTIONS CAREFULLY BEFORE STARTING INSTALLATION. DO NOT ATTEMPT INSTALLATION ALONE; PERSONAL INJURY OR DAMAGE TO THE VEHICLE MAY RESULT. DRILLING IS REQUIRED**
- Starting at the driver side front, install the 12mm x 35mm Short Bolt Plate in the location pictured in **Figure 1A**. Next, insert the 12mm Nut Plate into the hole in the underside of the vehicle pictured in **Figure 1B**. Locate the driver side Front Frame Bracket and hang it from the previously installed Nut and Bolt Plates using (1) 12mm x 35mm Bolt, (2) 12mm Lock Washers, (2) 12mm Flat Washers and (1) 12mm Hex Nut, (**Figure 2**). Do not tighten hardware at this time.
- Locate the driver side Front Mounting Bracket and bolt it to the backside of the Frame Bracket using (2) 12mm x 35mm Hex Bolts, (4) 12mm Flat Washers, (2) 12mm Lock Washers and (2) 12mm Hex Nuts. Snug but do not tighten bolts at this time.

4. Moving to the driver side rear of the vehicle, determine the location and install the 12mm x 95mm Long Bolt Plate, **(Figure 4)**. Rotate Bolt Plate counter-clockwise 90 degrees or until it stops in frame channel.
  5. Hang the driver side Rear Mounting Bracket from the Bolt Plate using (1) 12mm Flat Washer, (1) 12mm Lock Washer and (1) 12mm Hex Nut. Snug but do not tighten at this time.
  6. Carefully unwrap the Sidebars and determine the Driver Sidebar from the picture on page 3, **(Figure 6)**. The step pad closest to the end of the tube goes toward the rear of the vehicle.
  7. Gently align and place the Sidebar onto the Mounting Brackets and hold it in place with the included (4) 8mm x 25mm Hex Bolts, (4) 8mm Lock Washers and (4) 8mm Flat Washers. Snug all hardware but do not tighten at this time.
  8. Adjust and level the Sidebar then tighten all Bracket-mounting hardware only. Next remove the Sidebar.
  9. Locate the driver side Front Support Bracket Tab and secure it to the Mounting Bracket using (1) 10mm x 35mm Hex Bolt, (2) 10mm Flat Washers, (1) 10mm Lock Washer and (1) 10mm Hex Nut. **Note:** This same tab also fits on The Passenger/Right Side Rear Bracket. Snug but do not tighten the bolt at this time. Rotate the Support Bracket next to the Pinch Weld on the vehicle and Drill a 1/4" hole through the pinch weld to secure the bracket.
- Tip A:** Clamp the bracket to the pinch weld and use the hole in the tab to guide the drill bit.  
**Tip B:** Mark this location for drilling, move tab then drill hole, **(Figure 5)**.
10. Attach the Support Tab using the included (1) 6mm x 35mm Hex Bolts, (2) 6mm Flat Washers and (1) 6mm Nylock Nut. Reinstall the Sidebar and tighten all hardware at this time.
  11. Repeat Steps 2 - 10 for passenger/right Sidebar

**To protect your investment**, wax this product after installing. Regular waxing is recommended to add a protective layer over the finish. Do not use any type of polish or wax that may contain abrasives that could damage the finish.

**For stainless steel:** Aluminum polish may be used to polish small scratches and scuffs on the finish. Mild soap may be used also to clean the Sidebar.

**For gloss black finishes:** Mild soap may be used to clean Sidebar.

### ***Driver Side Installation Shown***

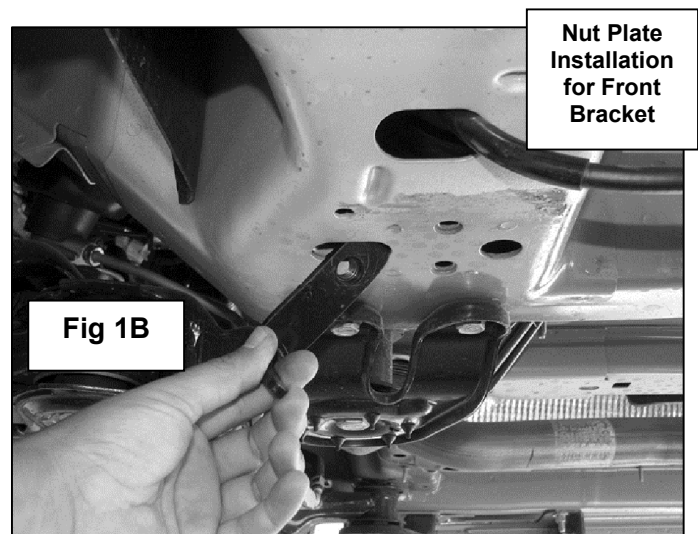
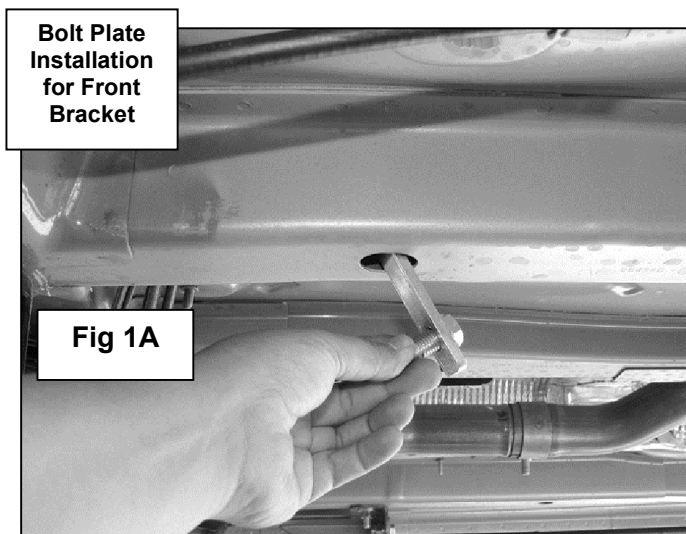



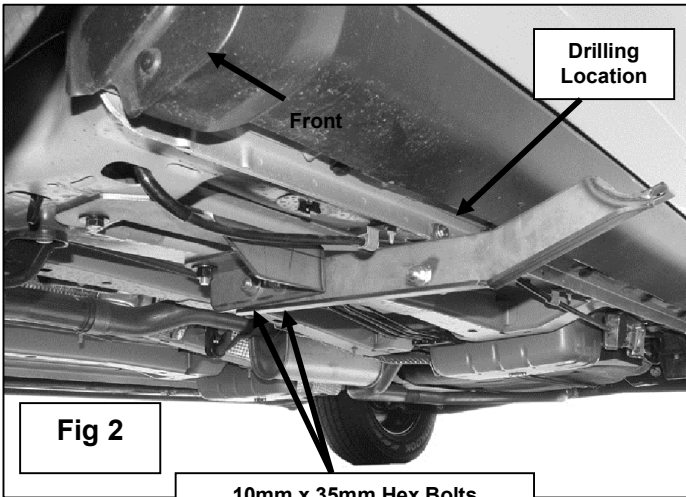

10mm x 35mm Hex Bolts  
10mm Lock Washers  
10mm Flat Washers

