

---

# SP300

4-AXIS DRONE

---

**14<sup>+</sup>**  
FOR AGES

## USER MANUAL

Please read this manual carefully before flying and keep it well for future reference.

## » DISCLAIMER AND SAFETY GUIDELINES

1. DO NOT look directly into the drone light.



2. CAUTION: Dispose of drone and batteries in accordance with local regulations.



3. DO NOT fly above or near obstacles, crowds, open water, public road, high voltage power lines or trees.



4. DO NOT use the drone in severe weather conditions. These include wind, snow, rain, smog, hail, lightning, tornadoes or hurricanes.



5. A safe distance must be maintained from the drone at all times while it is operational. Avoid trap hazards such as hair, ribbons, necklaces, ties, and so on.



6. This product is not a toy and is not recommended for users under age 14.



7. Please fly the drone within the control range and always keep an eye on the flying.



8. Be sure to observe all local regulations, obtain appropriate authorizations and understand risks. Please note it is solely your responsibility to comply with all flight regulations.



SNAPTAIN accepts no liability for damage, injury or any legal responsibility incurred directly or indirectly from the use of this product. The user shall observe safe and lawful practices including, but not limited to, those set forth in these Safety Guidelines. SNAPTAIN reserves the right to update this user manual.

## » MAINTENANCE AND CARE

1. Thoroughly check the drone after crash or violent impact.
2. Do not charge battery before it cools down.
3. Remove the batteries if the products will not be in use for a long time.
4. Unplug the USB cable once the battery is fully charged.
5. Store the drone and remote in a cool, dry place away from direct sunlight.
6. Do not charge the battery next to inflammable materials, such as bed, carpet, wood floors or countertops etc., or on surfaces that are electrically conductive.
7. Please use the original battery provided. Use an incorrect type of battery may lead to fire hazards.
8. Do not dispose of the battery in fire or a hot oven, cut or mechanically crush the battery, as this may cause explosions.
9. Do not leave the battery in an extremely high-temperature environment that can result in an explosion or the leakage of flammable liquid or gas.
10. Do not expose the battery to the extremely low air pressure, as this may result in an explosion or the leakage of flammable liquid or gas.
11. To extend the battery's lifespan, recharge it at least once every three months if not using it for long periods of time.

## » PRODUCT OVERVIEW

### SP300 Drone

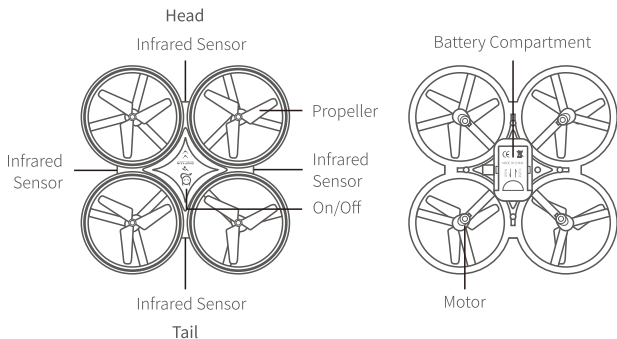

## G-sensor Watch Remote

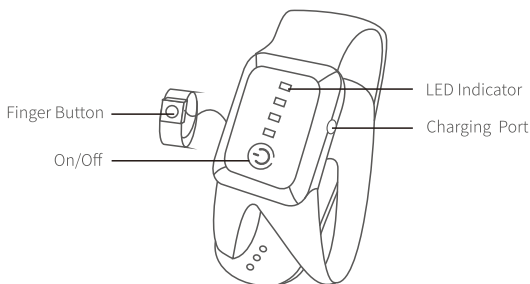

## Waterdrop-Shaped Remote



## Standard Mini Remote

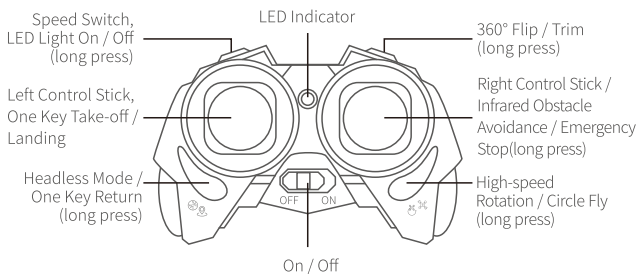

## » FLIGHT PREPARATION

1. Charge the G-sensor watch remote.

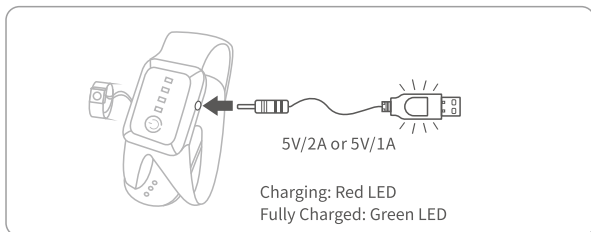

2. Wear the watch remote on your palm after it's fully charged.

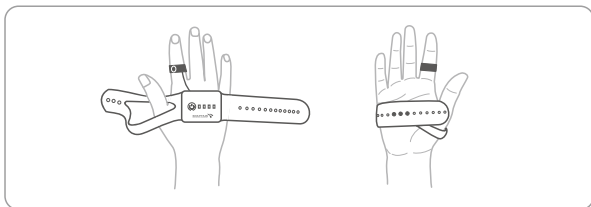

3. Install the remote batteries.

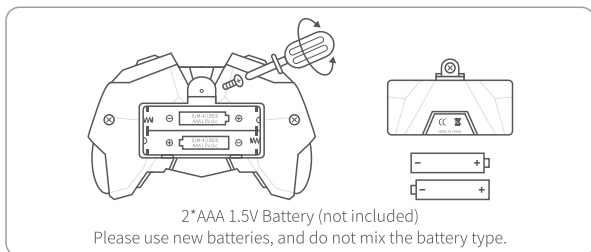

4. Charge the battery of the drone.

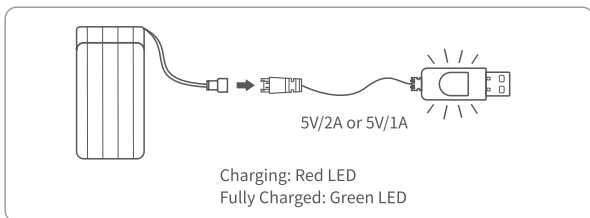

5. Install the drone battery after it's fully charged.

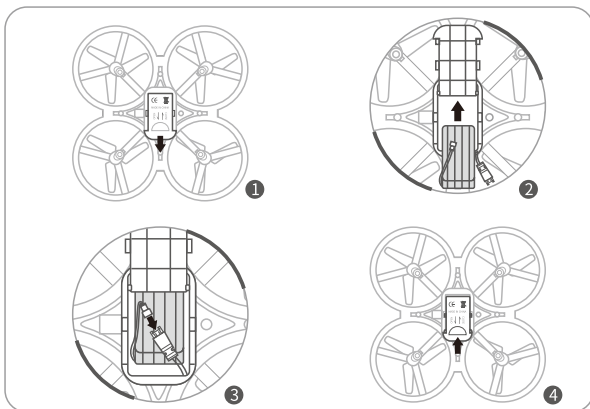

 Tips:

- ① For your safety, please use the original battery and USB cables provided.
- ② Flight time of the battery may be reduced when flying in cold weather.
- ③ Keep the Li-ion battery away from any sharp object that could puncture into it to avoid risks of explosion and fire.

## » FLIGHT OPERATION GUIDE

### **i** IMPORTANT

- \*Make sure you power on the drone first, then the remote in each flight.
- \*Do repeat the pairing procedure each time when the drone or remote is restarted.
- \*Calibration is a must to avoid losing your drone.
- \*For all flight functions and modes, the operator and tail of the drone must be aligned.
- \*We recommend flying in the open air and within the control range for beginners.

## Fly the drone with the G-sensor Watch Remote

### 1. Pair the watch remote with the drone

#### Step 1:

Press and hold the **On/Off** button for 2s to turn on the drone. The LEDs on it start flashing quickly, then flashing slowly. Place the drone on a flat surface with its head in the front.

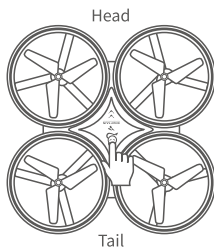

#### Step 2:

Shortly press the **On/Off** button to turn on the watch remote, and LEDs on the drone start flashing quickly again. Pairing is complete automatically when the LEDs on the drone turn to solid on.



## 2. Calibrate

Shortly press the **On/Off** button on the drone, then LEDs on the drone start flashing quickly. The calibration completes when the LEDs on the drone turn to solid on.



## 3. Flight Instructions

### Take-off

#### Step 1:

Clench your fist, then move it to make the watch remote to be horizontal with the earth's surface.

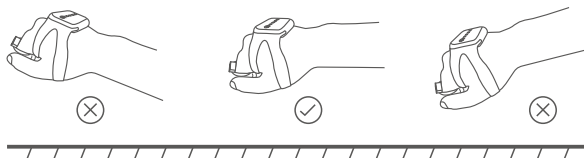

#### Step 2:

Shortly press the **Finger Button**, then release it. The drone will vertically take off to a height of 1.2M. Then follow the **Directions** below to fly it.

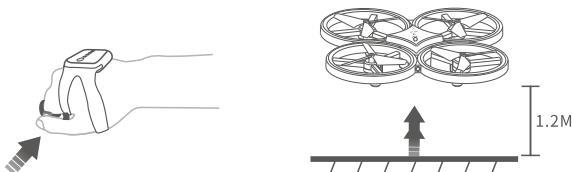

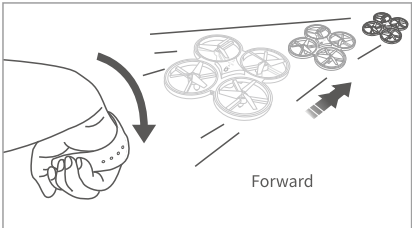
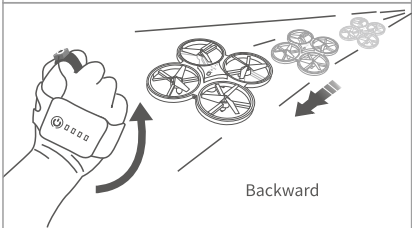
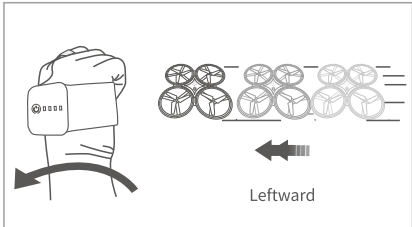
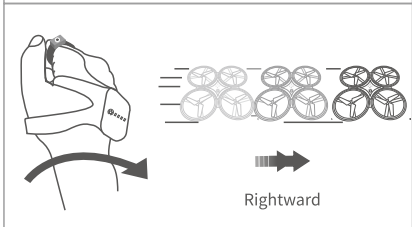

## Directions

|   |  |
|---|--|
|  <p>The diagram shows a hand holding a controller. A curved arrow indicates the hand tilting downwards. To the right, a drone is shown in three positions, moving from left to right. A straight arrow below the drone points to the right, labeled "Forward".</p>        | <p>Release the Finger Button during flight, then tilt your fist downward, and the drone will fly forward.</p>    |
|  <p>The diagram shows a hand holding a controller. A curved arrow indicates the hand tilting upwards. To the right, a drone is shown in three positions, moving from right to left. A straight arrow below the drone points to the left, labeled "Backward".</p>          | <p>Release the Finger Button during flight, then tilt your fist upward, and the drone will fly backward.</p>     |
|  <p>The diagram shows a hand holding a controller. A curved arrow indicates the hand leaning to the left. To the right, a drone is shown in three positions, moving from right to left. A straight arrow below the drone points to the left, labeled "Leftward".</p>     | <p>Release the Finger Button during flight, then lean your fist leftward, and the drone will fly leftward.</p>   |
|  <p>The diagram shows a hand holding a controller. A curved arrow indicates the hand leaning to the right. To the right, a drone is shown in three positions, moving from left to right. A straight arrow below the drone points to the right, labeled "Rightward".</p> | <p>Release the Finger Button during flight, then lean your fist rightward, and the drone will fly rightward.</p> |

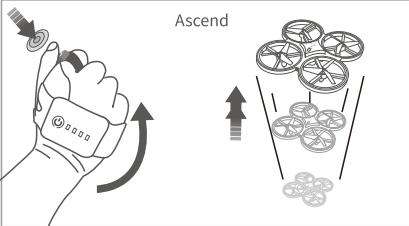
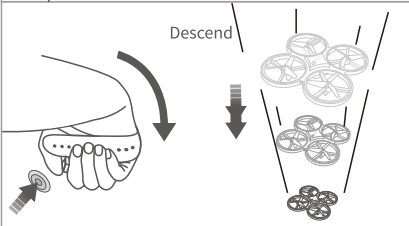
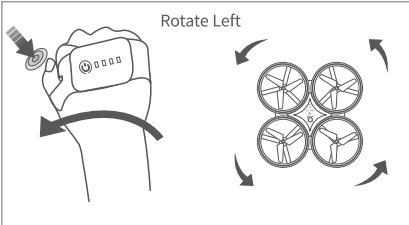
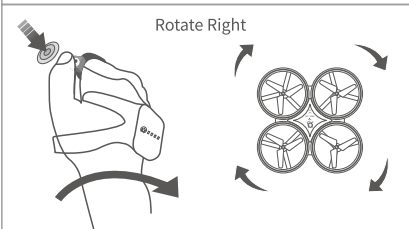
|  |   |
|--|---|
| <p style="text-align: center;">Ascend</p>           | <p>Press and hold the Finger Button during flight, then tilt your fist upward, and the drone will ascend.</p>                 |
| <p style="text-align: center;">Descend</p>         | <p>Press and hold the Finger Button during flight, then tilt your fist downward, and the drone will descend.</p>              |
| <p style="text-align: center;">Rotate Left</p>    | <p>Press and hold the Finger Button during flight, then lean your fist leftward, and the drone will rotate to the left.</p>   |
| <p style="text-align: center;">Rotate Right</p>  | <p>Press and hold the Finger Button during flight, then lean your fist rightward, and the drone will rotate to the right.</p> |

## 360° Flip

Move your fist to make the watch remote to be horizontal with the earth's surface during flight. Shortly press the **Finger Button**, then release it. The LEDs on the drone will start flashing quickly, then tilt/lean your fist forward/backward/leftward/rightward to flip the drone accordingly.

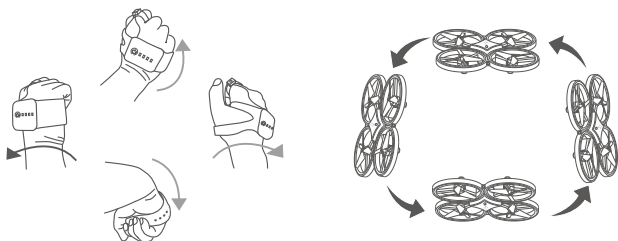

## Infrared Obstacle Avoidance

Continuously press the **Finger Button** for 3 times to activate **Infrared Obstacle Avoidance** mode during flight. The LEDs on the drone will flash for 3 times, then turn to solid on. The drone will fly to other directions when it detects an obstacle. Press the same button for 3 times again to cancel the mode.

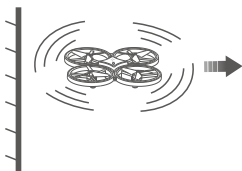
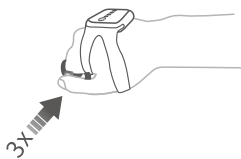

## Landing

Move your fist to make the watch remote to be horizontal with the earth's surface during flight, release the **Finger Button**, then simply press the **On/Off** button on the watch remote to land the drone.

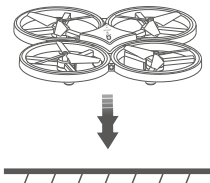

## Emergency Stop

Press and hold the **On/Off** button on the watch remote for 2s, the drone will stop flying and fall.



## Fly the drone with the waterdrop-shaped remote

### **i** IMPORTANT

\*Please turn off the G-sensor watch remote and the standard mini remote before using the waterdrop-shaped remote.

### 1. Power on the Drone

Press and hold the **On/Off** button for 2s to turn on the drone. The LEDs on it start flashing quickly, then flashing slowly. Place the drone on a flat surface with its head in the front.

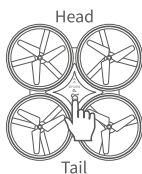

### 2. Calibrate

Shortly press the **On/off** button on the drone, then LEDs on the drone start flash quickly again. The calibration completes when the LEDs become flashing slowly.

### 3. Flight Instructions

#### Take-off

##### Option 1:

Shortly press the water-shaped remote to take off the drone.

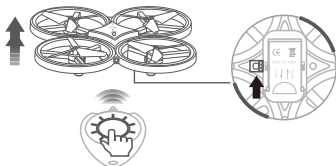

**Option 2:**

Place the drone in your palm with the head of drone in the front, then gently throw it into the air.

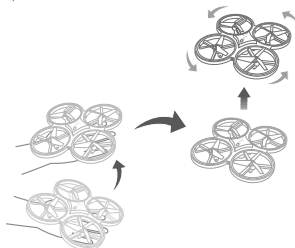

\*Please make sure there is enough space while throwing the drone up. We recommend this option only when the operator is skilled in basic operation.

After taking off, the drone will keep rotating slowly so that the infrared sensor can detect the surroundings.

**Directions**

|                 |  |
|-----------------|--|
| <p>Ascend</p>   | <p>Put your hand underneath the drone, it will ascend.</p>                                   |
| <p>Descend</p>  | <p>When the drone flies over a height of 1.2M, it will automatically and slowly descend.</p> |
| <p>Leftward</p> | <p>Put your hand on the right side of the drone, it will fly leftward.</p>                   |

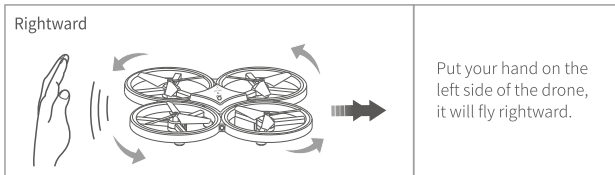

## Landing

Shortly press the water-shaped remote to land the drone during flight.

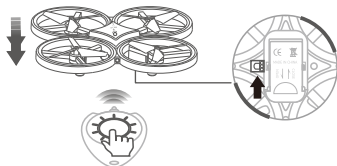

## Fly the drone with the standard mini remote

### 1. Pair the standard mini remote with the Drone

#### Step 1:

Press and hold the **On/Off** button for 2s to turn on the drone. The LEDs on it start flashing quickly, then flashing slowly. Place the drone on a flat surface with its head in the front.

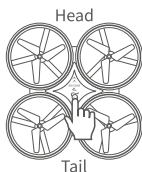

#### Step 2:

Turn on the remote. Push the **Left Control Stick** forward to the top, then pull it backward till the bottom. There is a beeping sound in each step. Pairing is successful when the LEDs on the drone are solid on.

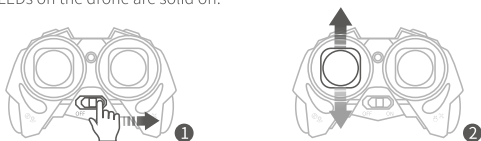

## 2. Flight Calibration

After successfully pairing the drone and remote, move both control sticks to lower right at 45° and hold for 2-3 secs to calibrate the drone. The calibration completes when the LEDs on the drone turn to solid on from quick flash.

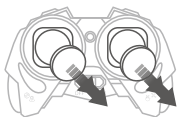

## 3. Flight Instructions

### Take-off

#### Option 1:

Press down the **Left Control Stick** to take off.

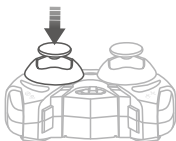

#### Option 2:

Move the **Left Control Stick** to lower left at 45° and the **Right Control Stick** to lower right at 45° at the same time until four propellers start rotating, then slowly push the **Left Control Stick** forward to take off.



## Directions

### Left Control Stick

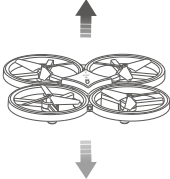
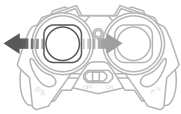
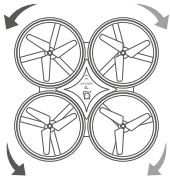
|  |   |  |
|--|---|--|
| <p>Ascend and descend</p>           |  | <p>Push the Left Control Stick forward and the drone will ascend; pull it backward and the drone will descend.</p>                           |
| <p>Rotate Left and Rotate Right</p>  |  | <p>Pull the Left Control Stick leftward and the drone will rotate to the left; pull it rightward and the drone will rotate to the right.</p> |

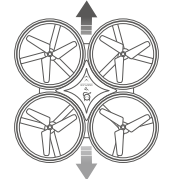
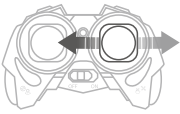
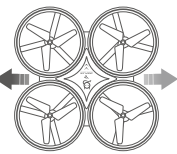

### Right Control Stick

|   |   |   |
|---|---|---|
| <p>Forward and Backward</p>     |   | <p>Push the Right Control Stick forward and the drone will fly forward; pull it backward and the drone will fly backward.</p>     |
| <p>Leftward and Rightward</p>  |  | <p>Pull the Right Control Stick leftward and the drone will fly leftward; pull it rightward and the drone will fly rightward.</p> |



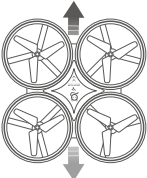

## Flight Trimming

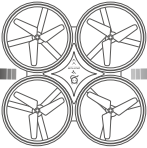
Proper trimming can help achieve a hovering flight.

|  |   |  |
|--|---|--|
|  |  | <p>If the drone drifts forward or backward when flying, press and hold on the 360° Flip button, then slightly move the Right Control Joystick backward or forward to adjust.</p>     |
|  |  | <p>If the drone drifts leftward or rightward when flying, press and hold on the 360° Flip button, then slightly move the Right Control Joystick rightward or leftward to adjust.</p> |

Release the   button to cancel the trimming mode.

## 360° Flip

After flying the drone to a height over 2 meters, shortly press the   button to activate 360° Flip function, then release it. Move the **Right Control Stick** forward/backward/leftward/rightward to flip the drone 360° accordingly.

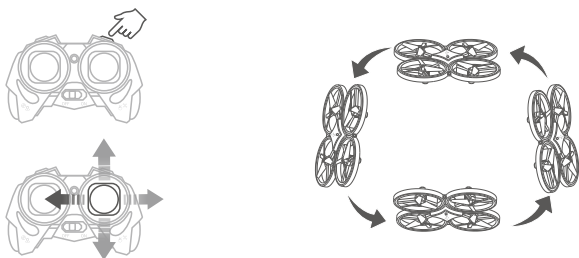

\*This function can not be activated when the battery of drone is low.

## LED Light On/Off

Press and hold the  button for 3s to turn on/off the light of the drone.

## Speed Switch

The drone is set to low speed by default. Press the  button once for medium speed and there are two beeps from the remote. Press it again for high speed and there are three beeps from the remote. A third press will get back to low speed and there is one beep from the remote.

## One Key Return

Long press the  button, the drone will fly toward its back following a path that parallels with its original take-off path. Long press the button again to cancel the mode.

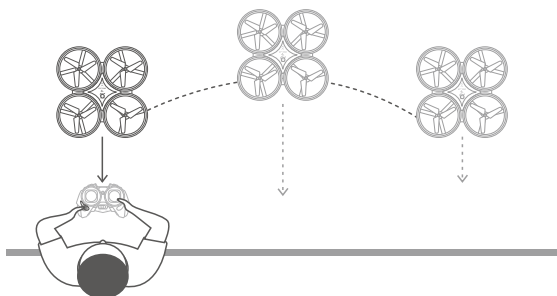

## Headless Mode

Shortly press the  button to activate the function. The LEDs on the drone will flash and there is beeping sound from the remote. In this mode, the drone will fly following the direction of the **Right Control Stick** regardless of the position of your drone's head or the tail. Press the same button again to exit this mode.

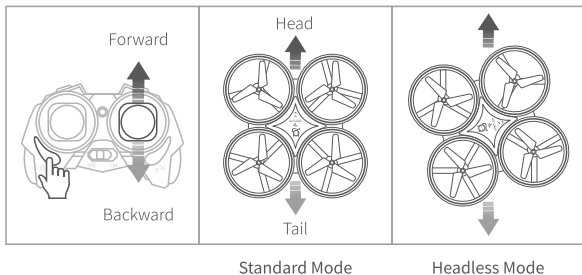

## High-Speed Rotation & Circle Fly

Shortly press the  button to rotate the drone with high speed. Press the button again or move the **Right Control Stick** to any direction to exit the High-speed Rotation mode.

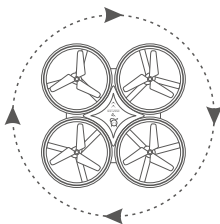

Long press the  button to fly the drone in circles; long press the button again or move the **Right Control Stick** to any direction to exit the Circle Fly mode.

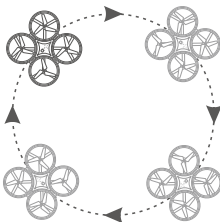

\*This function can not be activated when the battery of drone is low.

## Infrared Obstacle Avoidance

Press down the **Right Control Stick** to activate the **Infrared Obstacle Avoidance** mode. The drone will fly to other directions when it detects an obstacle. Press it down again to cancel the mode.

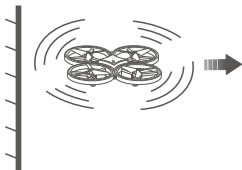
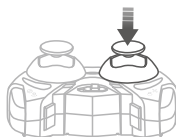

## Landing

### Option 1:

Press down the **Left Control Stick** to land.

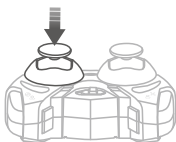

### Option 2:

During flight, pull the **Left Control Stick** backward to the bottom to land the drone, and hold it for 3s at least until all the rotor blades stop rotating.

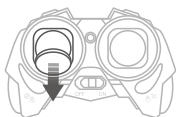

## Emergency Stop

Press down and hold the **Right Control Stick** for 3s, the drone will stop flying and fall.

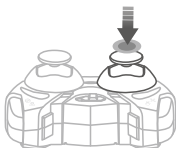

## Altitude Hold/Hover

This is one of the default settings in the drone. When you release the **Left Control Stick** after the ascending/descending action, the drone will hover at the current flight height. Proper trimming can help achieve a stable flight.

## » TROUBLESHOOTING GUIDE

### Q1. Drone LEDs do not light up.

- \*Press the On/Off button on the drone;
- \*Replace or charge the battery of drone.
- \*Make sure the connectors of the battery are plugged in firmly.

### Q2. Drone LEDs keep flashing, but the drone never responds to any command from the standard mini remote.

- \*Pair the drone and remote again.
- \*Replace or charge the battery of drone.
- \*Make sure the batteries in remote have enough power.
- \*Make sure to turn off the G-sensor watch remote.

### Q3. The flight is not stable.

- \*Return the drone and restart to do a calibration as instructed.
- \*Make the flight trimming accordingly.
- \*Fly the drone when the weather is good.

### Q4. The response from the drone to the control is not sensitive.

- \*Make sure the distance between the drone and remote is effective.

### Q5. The drone will fly beyond the control range.

- \*Activate the **Headless mode**, then move the **Right Control Stick** to fly the drone back.

### Q6. Replace the rotor blades.

- \*The propellers and motors are marked with A and B letter. Please pair them when replacing the rotor blades.

### Q7. The water-shaped remote doesn't work.

- \*Make sure you turn off the G-sensor watch remote and standard mini remote.

## » SPECIFICATIONS

| Drone                 |                             |
|-----------------------|-----------------------------|
| Operating Temperature | 32°F to 104°F (0°C to 40°C) |
| Frequency Range       | Model SP300: 2405~2438 MHz  |

|                       |                            |
|-----------------------|----------------------------|
| <b>Remote</b>         |                            |
| Frequency Range       | Model SP300: 2405~2438 MHz |
| Transmit Power (EIRP) | Model SP300: 2.4GHz<18dBm  |
| <b>USB Cable</b>      |                            |
| Input                 | 5V $\overline{=}$ 1~2A     |
| Output                | 4.2V $\overline{=}$ 500mA  |
| Rated Power           | 2.1W                       |

### FCC Caution:

Any Changes or modifications not expressly approved by the party responsible for compliance could void the user's authority to operate the equipment.

This device complies with part 15 of the FCC Rules. Operation is subject to the following two conditions: (1) This device may not cause harmful interference, and (2) this device must accept any interference received, including interference that may cause undesired operation.

Note: This equipment has been tested and found to comply with the limits for a Class B digital device, pursuant to part 15 of the FCC Rules. These limits are designed to provide reasonable protection against harmful interference in a residential installation. This equipment generates, uses and can radiate radio frequency energy and, if not installed and used in accordance with the instructions, may cause harmful interference to radio communications. However, there is no guarantee that interference will not occur in a particular installation. If this equipment does cause harmful interference to radio or television reception, which can be determined by turning the equipment off and on, the user is encouraged to try to correct the interference by one or more of the following measures:

- Reorient or relocate the receiving antenna.
- Increase the separation between the equipment and receiver.
- Connect the equipment into an outlet on a circuit different from that to which the receiver is connected.
- Consult the dealer or an experienced radio/TV technician for help.

For Remote:

This equipment complies with FCC radiation exposure limits set forth for an uncontrolled environment.

For R/C QUADCOPTER:

This equipment complies with FCC radiation exposure limits set forth for an uncontrolled environment. This equipment should be installed and operated with minimum distance 20cm between the radiator & your body.

This transmitter must not be co-located or operating in conjunction with any other antenna or transmitter.

## ISED Warning:

This device complies with Industry Canada licence-exempt RSS standard(s). Operation is subject to the following two conditions:

- (1) this device may not cause interference, and
- (2) this device must accept any interference, including interference that may cause undesired operation of the device.

Le présent appareil est conforme aux CNR d'Industrie Canada applicables aux appareils radio exempts de licence. L'exploitation est autorisée aux deux conditions suivantes :

- (1) l'appareil ne doit pas produire de brouillage, et
- (2) l'utilisateur de l'appareil doit accepter tout brouillage radioélectrique subi, même si le brouillage est susceptible d'en compromettre le fonctionnement.

For R/C QUADCOPTER:

The device is compliance with RF exposure guidelines, users can obtain Canadian information on RF exposure and compliance. The minimum distance from body to use the device is 20cm.

L'appareil est conforme aux directives d'exposition aux RF, les utilisateurs peuvent obtenir des informations canadiennes sur l'exposition aux RF et la conformité. La distance minimale du corps pour utiliser l'appareil est de 20 cm.

For Remote:

The device is compliance with RF exposure guidelines, users can obtain Canadian information on RF exposure and compliance.

Le présent appareil est conforme Après examen de ce matériel aux conformité ou aux limites d'intensité de champ RF, les utilisateurs peuvent sur l'exposition aux radiofréquences et la conformité and compliance d'acquérir les informations correspondantes.

This transmitter must not be co-located or operating in conjunction with any other antenna or transmitter.

Cet émetteur ne doit pas être colocalisé ou fonctionner en conjonction avec une autre antenne ou un autre émetteur.

## CAUTION

RISK OF EXPLOSION IF BATTERY IS REPLACED BY AN INCORRECT TYPE

DISPOSE OF USED BATTERIES ACCORDING TO THE INSTRUCTIONS



The symbol indicates DC voltage



RECYCLING

This product bears the selective sorting symbol for Waste electrical and electronic equipment (WEEE). This means that this product must be handled pursuant to European directive 2012/19/EU in order to be recycled or dismantled to minimize its impact on the environment. User has the choice to give his product to a competent recycling organization or to the retailer when he buys a new electrical or electronic equipment.

This product can be used across EU member states.

The device is low power device, it can meet the requirement of the RF exposure.

EU Compliance Statement: Shenzhen VanTop Technology & Innovation Co., Ltd. hereby declares that this device is in compliance with the essential requirements and other relevant provisions of the Directive 2014/53/EU.

A copy of the EU Declaration of Conformity is available online at <https://doc.vantop.com/>.



BATTERY MUST BE RECYCLED OR DISPOSED OF PROPERLY

## Manufacturer

Shenzhen VanTop Technology & Innovation Co., Ltd.

Manufacturer address:

502, 5th Flr. BLDG 4, MinQi Technology Park, No. 65 Lishan Road, Taoyuan Street,  
Nanshan District, Shenzhen, China

|    |     |
|----|-----|
| EC | REP |
|----|-----|

C&E Connection E-Commerce (DE) GmbH  
Zum Linnegraben 20, 65933, Frankfurt am Main, Germany  
[Info@ce-connection.de](mailto:Info@ce-connection.de)



## SNAPTAIN SUPPORT

US : support@snaptain.com

CA : support@snaptain.com

UK : support.uk@snaptain.com



[www.snaptain.com](http://www.snaptain.com)



[@snaptainofficial](https://www.facebook.com/snaptainofficial)



[@snaptain\\_official](https://www.instagram.com/snaptain_official)