

iQSFP-SR-300m

40Gb/s QSFP+ SR4 Transceiver

Product Features

- High Channel Capacity: 40Gbps per module
- Up to 11.1Gbps Data rate per channel
- Maximum link length of 300m links on OM4 multimode fiber
- Or 150m on OM4 multimode fiber
- High Reliability 850nm VCSEL technology`
- Electrically hot-pluggable
- Compliant with QSFP+ MSA
- Case operating temperature range:0°C to 70°C
- Power dissipation < 1.5 W



Applications

- 40G Ethernet
- Infiniband QDR
- Fiber channel

Standard

- Compliant to IEEE 802.3ba
- Compliant to SFF-8436
- RoHS Compliant.

General Description

Xmethod Network iQSFP-SR-300m QSFP+ SR4 transceiver modules are designed for use in 40 Gigabit per second links over multimode fiber. They are compliant with the QSFP+ MSA and IEEE 802.3ba 40GBASE-SR4. The optical transmitter portion of the transceiver incorporates a 4-channel VCSEL (Vertical Cavity Surface Emitting Laser) array, a 4-channel input buffer and laser driver, control and bias blocks. The optical receiver portion of the transceiver incorporates a 4-channel PIN photodiode array, a 4-channel TIA array, a 4 channel output buffer, control blocks.

Absolute Maximum Ratings

Parameter	Symbol	Min.	Typ.	Max.	Unit	Note
Storage Temperature	Ts	-40	-	85	°C	
Storage Ambient Humidity	HA	5	-	95	%	
Operating Relative Humidity	RH	-	-	85	%	
Power Supply Voltage	VCC	-0.3	-	4	V	
Signal Input Voltage		Vcc-0.3	-	Vcc+0.3	V	
Damage threshold		3.4			dBm	

Recommended Operating Conditions

Parameter	Symbol	Min.	Typ.	Max.	Unit	Note
Case Operating Temperature	Tcase	0	-	70	°C	Without air flow
Power Supply Voltage	VCC	3.14	3.3	3.47	V	
Power Supply Current	ICC	-		350	mA	
Data Rate	BR		10.3125		Gbps	Each channel
Transmission Distance	TD		-	150	m	OM3 MMF
				300	m	OM4 MMF

Optical Characteristics

Parameter	Symbol	Min	Typ	Max	Unit	NOTE
Transmitter						
Center Wavelength	λ_0	840		860	nm	
Average Launch Power each lane			-7.6	-1	dBm	
Spectral Width (RMS)	σ			0.65	nm	
Optical Extinction Ratio	ER	3			dB	
Average launch Power off each lane	Poff			-30	dBm	
Transmitter and Dispersion Penalty each lane	TDP			3.5	dB	
Optical Return Loss Tolerance	ORL			12	dB	
Output Eye Mask	Compliant with IEEE 802.3ba					
Receiver						
Receiver Wavelength	λ_{in}	840		860	nm	
Rx Sensitivity per lane	RSENS			-9.5	dBm	1
Input Saturation Power (Overload)	Psat	2.4			dBm	
Receiver Reflectance	Rr			-12	dB	
LOS De-Assert	LOSD			-12	dBm	
LOS Assert	LOSA	-30			dBm	
LOS Hysteresis		0.5			dBm	

Notes:

Measured with a PRBS 231-1 test pattern, @10.325Gb/s, BER<10⁻¹².

Electrical Characteristics

Parameter	Symbol	Min	Typ	Max	Unit	NOTE
Supply Voltage	Vcc	3.14	3.3	3.46	V	
Supply Current	Icc			350	mA	
Transmitter						
Input differential impedance	Rin		100		Ω	1
Differential data input swing	Vin,pp	180		1000	mV	
Single ended input voltage tolerance	VinT	-0.3		4.0	V	
Receiver						
Differential data output swing	Vout,pp	300		850	mV	2
Single-ended output voltage		-0.3		4.0	V	

Notes:

1. Connected directly to TX data input pins. AC coupled thereafter.
2. Into 100 ohms differential termination.

Pin Assignment

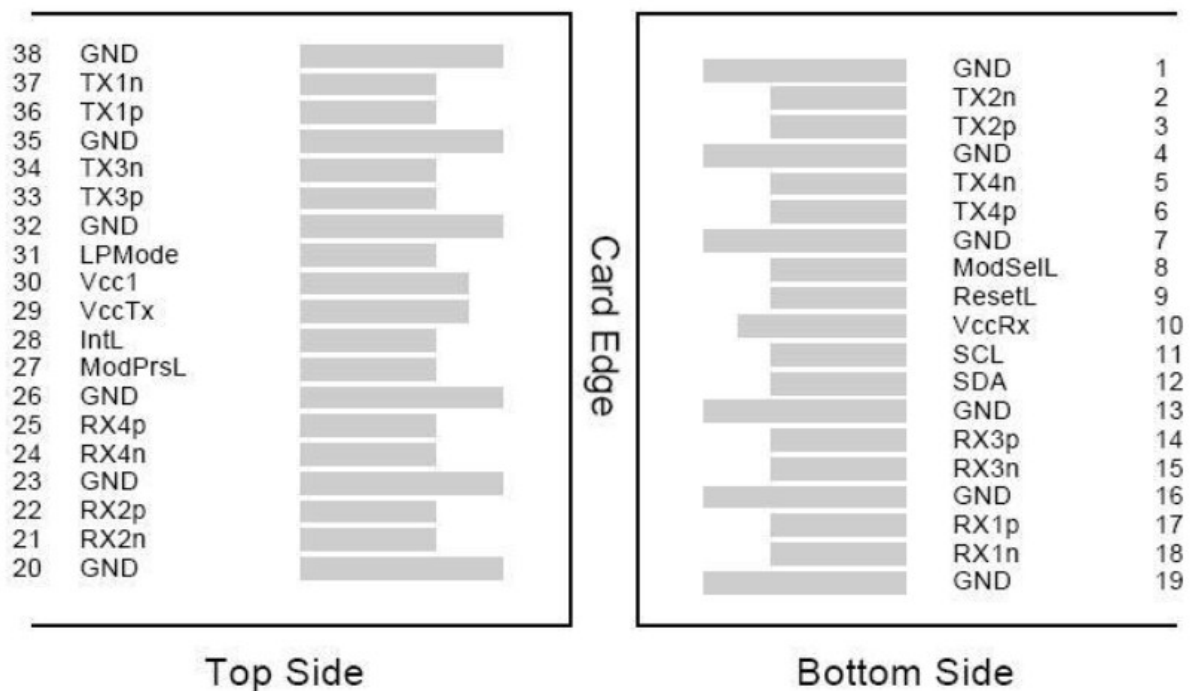

Figure 1---Pin out of Connector Block on Host Board

Pin	Symbol	Name/Description	NOTE
1	GND	Transmitter Ground (Common with Receiver Ground)	1
2	Tx2n	Transmitter Inverted Data Input	
3	Tx2p	Transmitter Non-Inverted Data output	
4	GND	Transmitter Ground (Common with Receiver Ground)	1
5	Tx4n	Transmitter Inverted Data Input	

6	Tx4p	Transmitter Non-Inverted Data output	
7	GND	Transmitter Ground (Common with Receiver Ground)	1
8	ModSelL	Module Select	
9	ResetL	Module Reset	
10	VccRx	3.3V Power Supply Receiver	2
11	SCL	2-Wire serial Interface Clock	
12	SDA	2-Wire serial Interface Data	
13	GND	Transmitter Ground (Common with Receiver Ground)	
14	Rx3p	Receiver Non-Inverted Data Output	
15	Rx3n	Receiver Inverted Data Output	
16	GND	Transmitter Ground (Common with Receiver Ground)	1
17	Rx1p	Receiver Non-Inverted Data Output	
18	Rx1n	Receiver Inverted Data Output	
19	GND	Transmitter Ground (Common with Receiver Ground)	1
20	GND	Transmitter Ground (Common with Receiver Ground)	1
21	Rx2n	Receiver Inverted Data Output	
22	Rx2p	Receiver Non-Inverted Data Output	
23	GND	Transmitter Ground (Common with Receiver Ground)	1
24	Rx4n	Receiver Inverted Data Output	1
25	Rx4p	Receiver Non-Inverted Data Output	
26	GND	Transmitter Ground (Common with Receiver Ground)	1
27	ModPrsl	Module Present	
28	IntL	Interrupt	
29	VccTx	3.3V power supply transmitter	2
30	Vcc1	3.3V power supply	2
31	LPMODE	Low Power Mode	
32	GND	Transmitter Ground (Common with Receiver Ground)	1
33	Tx3p	Transmitter Non-Inverted Data Input	
34	Tx3n	Transmitter Inverted Data Output	
35	GND	Transmitter Ground (Common with Receiver Ground)	1
36	Tx1p	Transmitter Non-Inverted Data Input	
37	Tx1n	Transmitter Inverted Data Output	
38	GND	Transmitter Ground (Common with Receiver Ground)	1

Notes:

1. GND is the symbol for signal and supply (power) common for QSFP+ modules. All are common within the QSFP+ module and all module voltages are referenced to this potential unless otherwise noted. Connect these directly to the host board signal common ground plane.
2. VccRx, Vcc1 and VccTx are the receiving and transmission power suppliers and shall be applied concurrently. Recommended host board power supply filtering is shown below. Vcc Rx, Vcc1 and Vcc Tx may be internally connected within the QSFP+ transceiver module in any combination. The connector pins are each rated for a maximum current of 500mA.

Host - Transceiver Interface Block Diagram

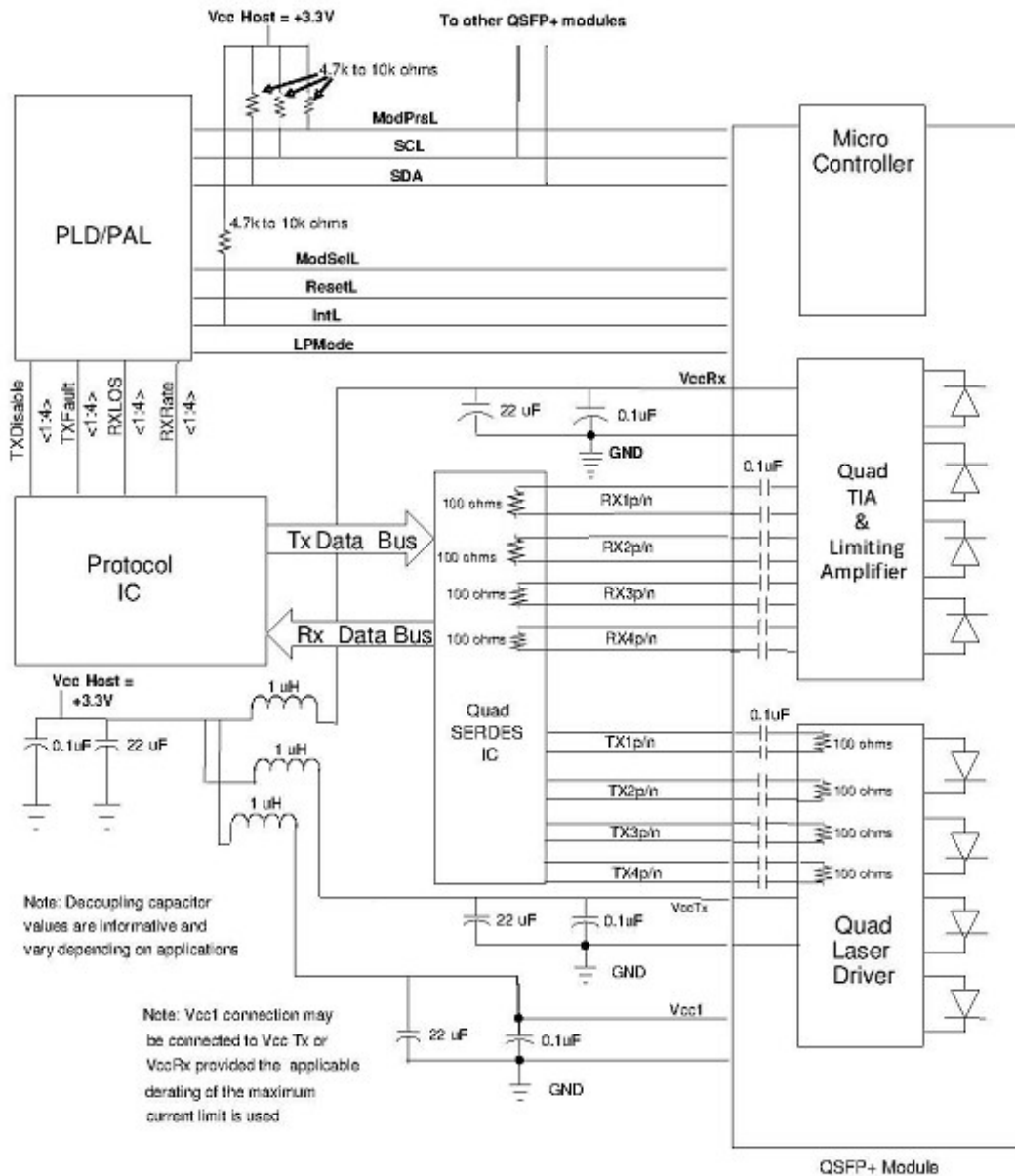

Outline Dimensions

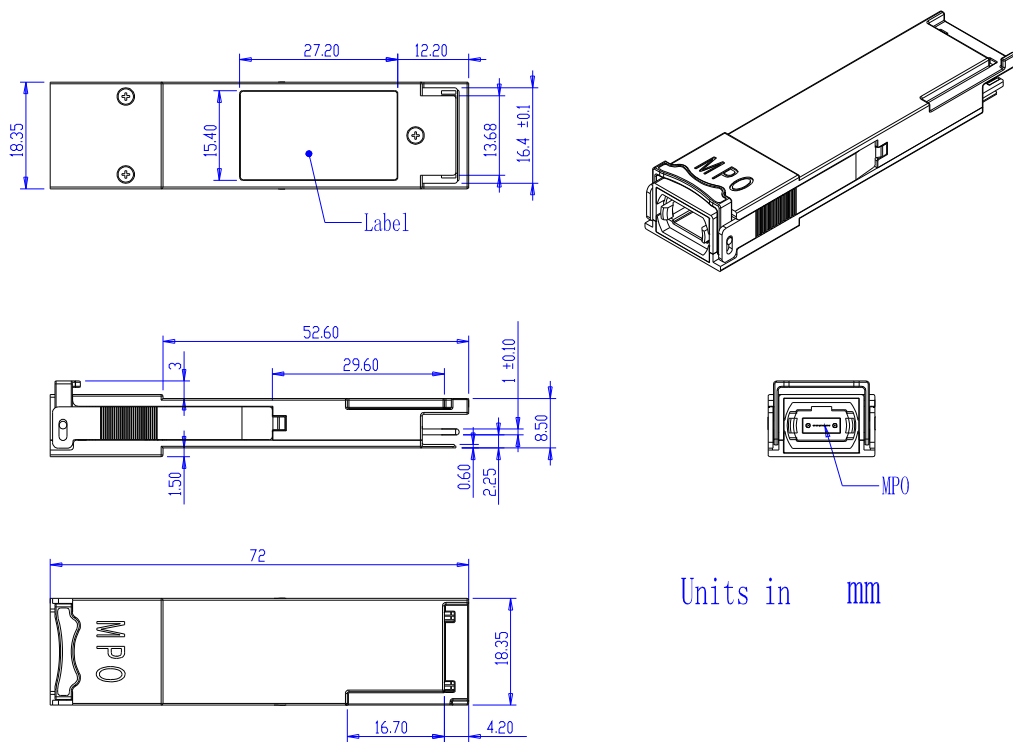

Ordering information

Part Number	Product Description
iQSFP-SR-300m	850nm VCSEL, 40Gbps, 150m, 0°C ~ +70°C, DDM

Revision History

Revision	Notes	Authors	Checked	Approval	Date
Rev A0	/New release	Dean Xue	Granger Leung	John Liu	2014.10.29