

**1** PAS

**2** Thottle

**3** Light Power Output

**4** Brake Lever \*2

**5** 25KM/H Limited

**6** Display

**7** Electronic lock

**8** Motor's Phase Cable 5.5mm

**9** XT60 Male 12AWG

**10** Motor's Hall sensor

# Controller Diagram

## Power Input



Black VB-  
Red VB+

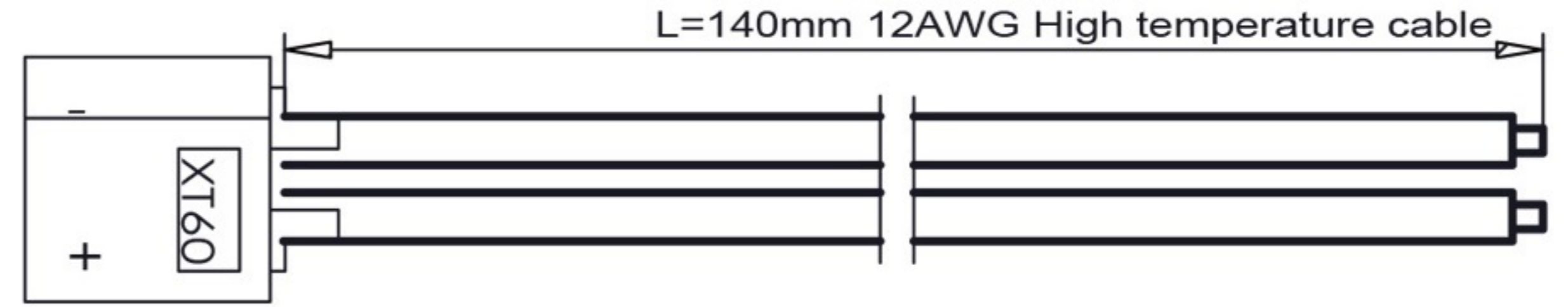

## 3-Phase



## Hall Sensor

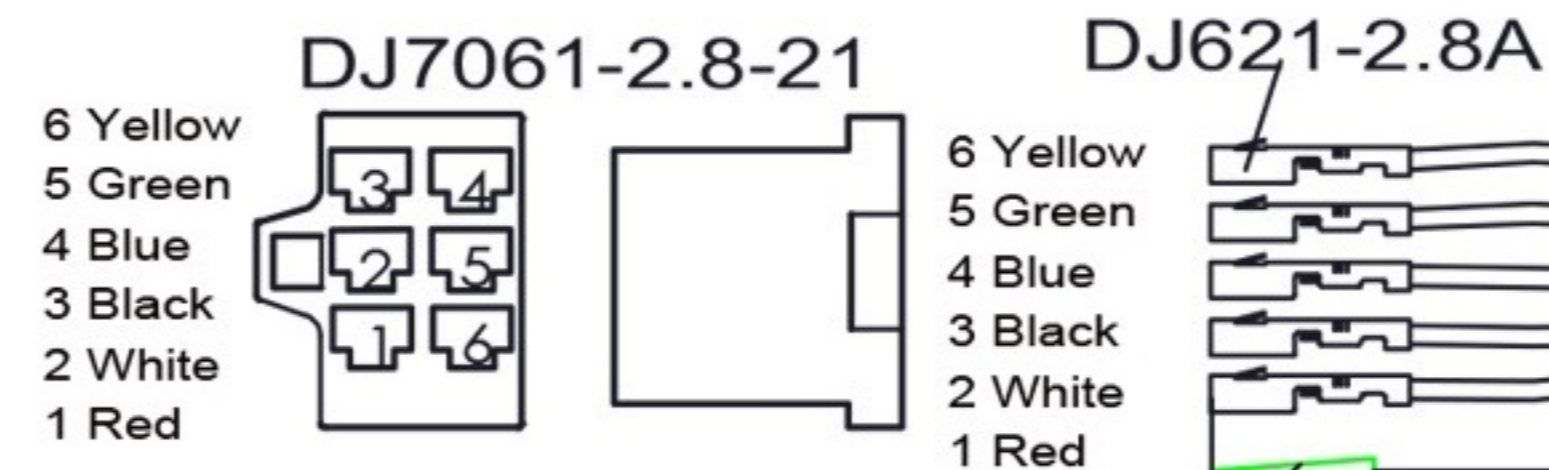
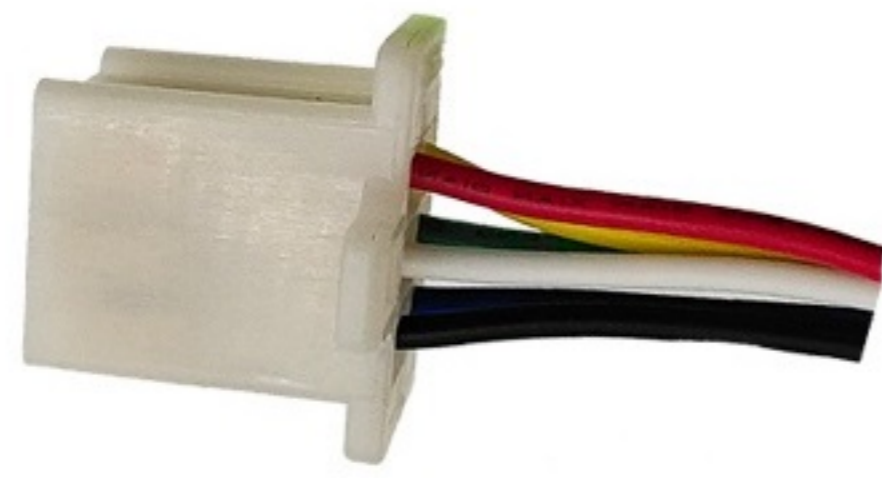

## Brake Lever

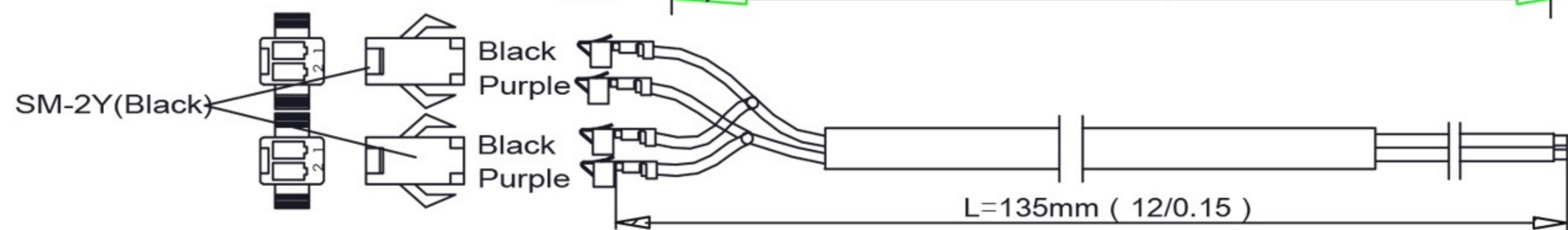

## Throttle

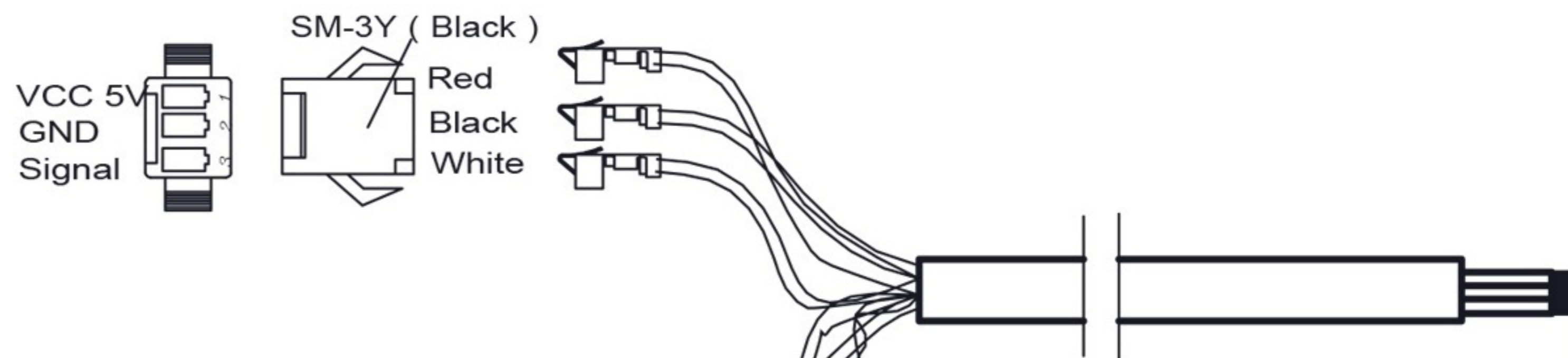

## PAS

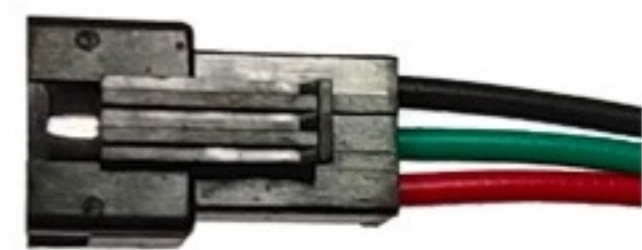

PAS

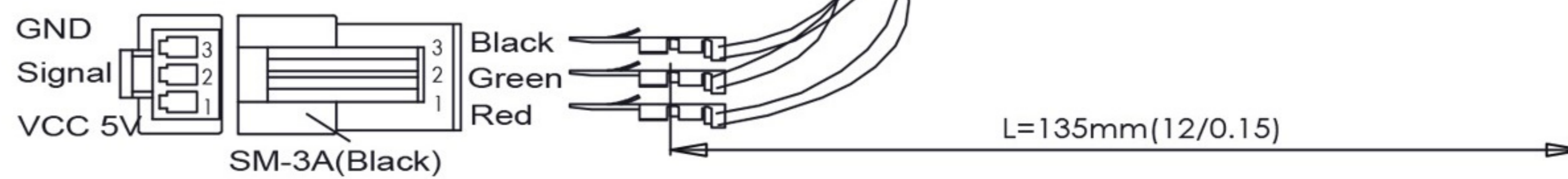

## Light



## Electric Lock

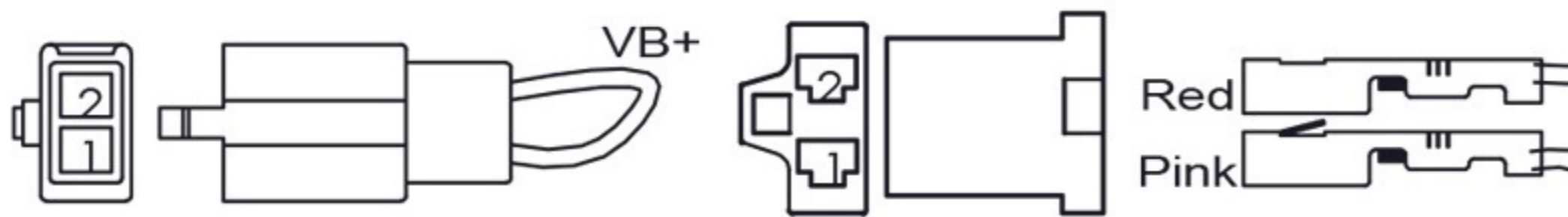

## Display

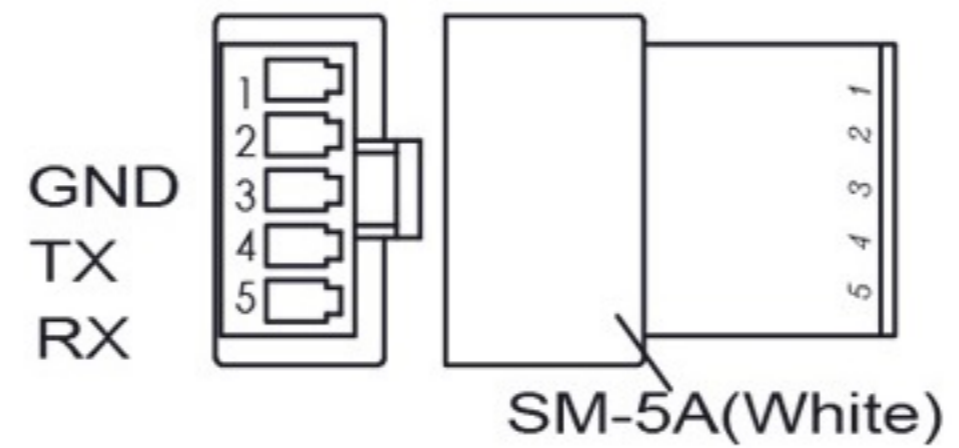

## Speed Limit

