

3A Regulated, Constant Current, Buck-Boost, Single Cell, Programmable eSwitch Flashlight Driver with Direct Drive FET

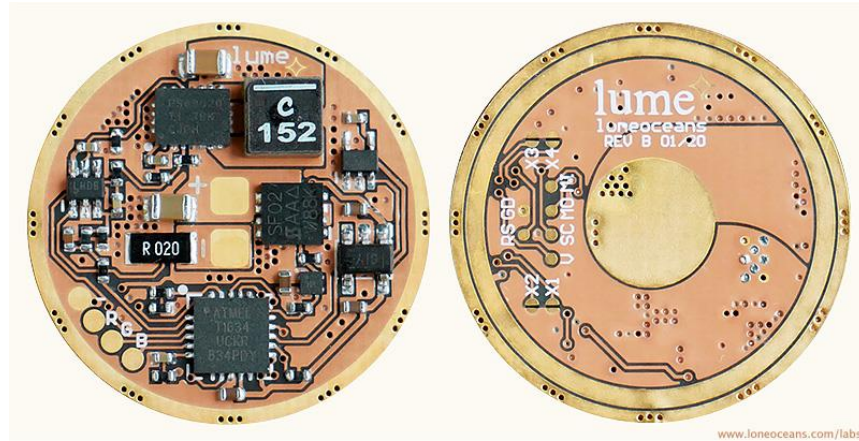

1 Features

- Designed specifically for FW3x eSwitch Flashlights
 - 21.7mm Driver Diameter
 - Very Low Z-Height for FW3x Compatibility
 - Drop-in Replacement over Stock Driver
- 3A Regulated True Constant-Current Output with 1024-Levels of Resolution
- High-Efficiency Synchronous Buck-Boost Operation up to 93.5% Overall Driver Efficiency
- Low R_{dsON} Direct-Drive N-FET Boost Drive with Reverse Current Blocking during Boost Mode
- MCU-external Temperature Sensor for $\pm 1^\circ\text{C}$ Increased Accuracy and Precision
- Auxiliary RGB LED Support
- Supports 1S Single Cell Lithium-Ion Batteries
- Very Low 30 μA Standby Current
- Completely Acoustically Silent Operation
- ATTINY1634 Programmable Microcontroller
- Open-Sourced Anduril UI Firmware
- Designed for use with 2:4 Pogo-Pin Programming
- Four Additional Solder Jumper Pads for Future Expansion Capabilities

2 Description

The LUME1-FW3X driver belongs to the LUME1 family of high-performance constant-current buck-boost single-channel drivers with on-board direct-drive FET for Turbo.

The LUME1-FW3X is designed specifically as a drop-in driver replacement for the FW3X family of tail e-switch flashlights. The LUME1 driver improves on the stock FW3X driver with significantly higher efficiency (and thus run-time) across the entire range of input voltages from a

single lithium cell. The LUME1 driver also adds additional features such as auxiliary RGB LED support and improved temperature sensing.

The LUME1 driver employs a current-mode synchronous 4-switch buck-boost architecture with automatic transition between buck and boost modes, as cell voltage varies. Constant-current regulation is achieved by constantly monitoring output current and modulating buck-boost output to the desired power level. Unlike conventional linear flashlight drivers which regulate current through linear pass-elements and modulate brightness via PWM, the LUME1 driver achieves significantly higher efficiency with its switching topology, eliminates PWM flickering, and maintains a true regulated output across the entire battery voltage range even during low V_{BAT} in low ambient temperatures.

For additional output power, the LUME1 driver implements 'Direct-Drive' TURBO mode via low R_{dsON} NFETs with reverse current protection. Thermal regulation and protection are achieved with a discrete temperature sensor with a $\pm 1^\circ\text{C}$ accuracy, significantly improving on the stock FW3X driver. As an e-switch driver that is always on, the LUME1 driver is also designed with a low 30 μA standby quiescent current for excellent standby duration.

To enable and encourage hobbyists and engineers, the LUME1 driver is designed to support open-source firmware for e-switch type flashlights, such as Anduril. Programming of the on-board ATTINY1634 MCU is conveniently done via community friendly 2:4 pogo-pin pads. Finally, the LUME1 driver incorporates four additional solder jumper pads for future user customization and configurability.

3 Driver Configuration and Pads

The LUME1-FW3X driver is a monolithic, assembled PCBA, ready for integration within a flashlight host. Solder pads are labeled as follows and are on both top and bottom of the PCB.

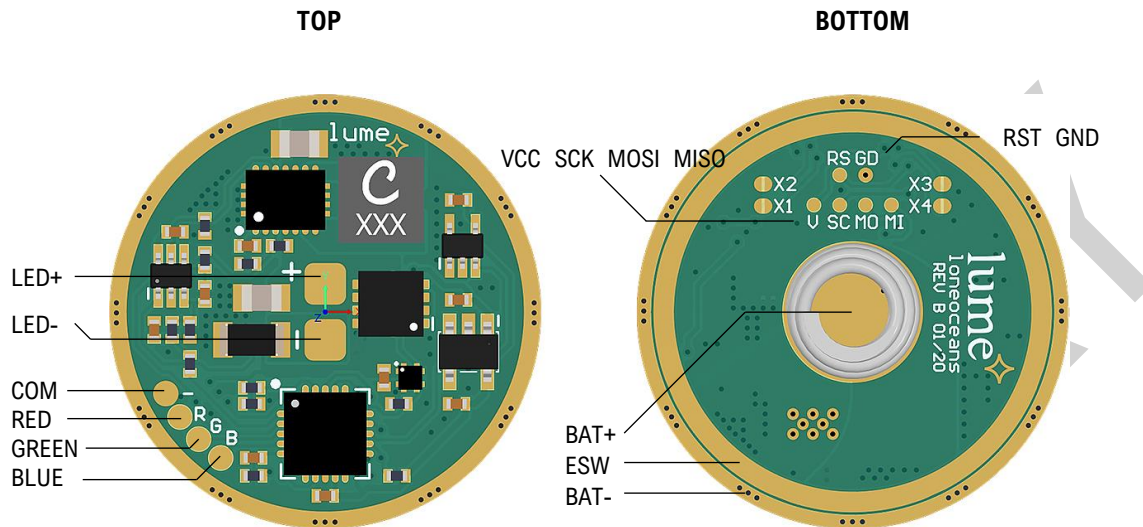

3.1 Pad Functions

PAD NAME	I/O	DESCRIPTION
LED+	O	Output of LUME1 driver, must be connected to main LED anode.
LED-	-	Must be connected to main LED cathode. Return path of LED+.
RED	O	Connect to Red LED anode on Auxiliary LED board, can be left floating.
GREEN	O	Connect to Green LED anode on Auxiliary LED board, can be left floating.
BLUE	O	Connect to Blue LED anode on Auxiliary LED board, can be left floating.
COM	-	Common Cathode of RGB LEDs on Auxiliary LED board, electrically connected to BAT- / GND.
ESW	I	Electronic Switch control pin. Pull this pin momentarily low to register as a switch press.
BAT+	I	Must be connected to positive terminal of battery, typically via the battery spring.
BAT-	-	Must be connected to negative terminal of battery. Acts as system GND.
MISO	I/O	Used during MCU flashing, connect to MISO pin of In-System Programmer (ISP).
MOSI	I/O	Used during MCU flashing, connect to MOSI pin of ISP programmer.
SCK	I	Used during MCU flashing, connect to SCK pin of ISP programmer. Programming clock line generated by ISP programmer.
VCC	I/O	Used during MCU flashing, connected to output of on-board 2.5V Voltage Regulator when powered. Supply with 2.7V - 3.3V when programming internal MCU. On-board Voltage Regulator has reverse current protection.
GND	-	Used during MCU flashing, connect to GND of ISP programmer, electrically connected to system GND.
RST	I	Used during MCU flashing, internally pulled high to VCC via 10k, connect to /RST pin of ISP programmer.
X1, X2, X3, X4	I	Solder-pad jumpers 1 to 4, pulled high internally to VCC. Short solder pads to use. Implementation requires firmware support, not currently in use.

4 Specifications

4.1 Absolute Maximum Ratings

	PADS	MIN	MAX	UNIT
Voltage	BAT+	-0.3	5.5	V
	LED+, VCC	-0.3	5.5	V
	RED, GREEN, BLUE, ESW	-0.3	VCC + 0.5	V
	MISO, MOSI, SCK, RST, X1, X2, X3, X4	-0.3	5.5	V
Output Current	RED, GREEN, BLUE	-	40.0	mA
Temperature	Operating Onboard IC Junction Temperature	-55	125	°C
	Storage Temperature	-65	150	°C

Stresses to the product beyond those listed in Absolute Maximum Ratings may cause permanent damage. The values rated here are stress ratings and not recommended for normal operation. Operating the product at absolute-maximum-rating conditions for extended periods of time may affect overall reliability. Functionality of product is not guaranteed when operating the product outside Recommend Operating Conditions but within Absolute Maximum Ratings. Note that voltages listed are with respect to system GND terminal (BAT-).

4.2 Recommended Operating Conditions

	PADS	MIN	NOMINAL	MAX	UNIT
Voltages	BAT+ (single Lithium-Ion cell)	2.75	4.0	4.35	V
	LED+	-	3.0	5.5	V
	VCC_in During MCU Flashing	-	3.3	-	V
	MISO, MOSI, SCK, RST, X1, X2, X3, X4	-	3.3	-	V
Output Current	RED, GREEN, BLUE	-	-	5	mA
Temperature	Operating Onboard IC Junction Temperature	-40	-	125	°C
	Operating Ambient Temperature	-40	-	85	°C

* Maximum output current should not cause pass-FET junction temperature to exceed 150°C and sense resistor temperature to exceed 155°C. Maximum sustained output drive requires appropriate driver heat sinking.

4.3 Electrical Characteristics

Characteristics when BAT+ supplied with nominal 4.0V.

	PARAMETER	MIN	NOMINAL	MAX	UNIT
Voltage	BAT+	2.75	4.0	4.35	V
	LED+*	<1.2	3.3	5.5	V
	LED+ Overvoltage Protection	5.5	-	7.0	V
	VCC	-2%	2.5	+2%	V
	RED, GREEN, BLUE Output	2.0	2.5	VCC	V
	BAT+ Low Voltage Protection Threshold	-	2.8	-	V

Output Current	LED+ Minimum Regulated Current	-	3.0	3.3	mA
	LED+ Maximum Regulated Current**†	-	3000	-	mA
	LED+ Unregulated FET Drive Current [^]	-	-	> 20000	mA
	LED+ Output Current Resolution*	-	1024	-	levels
Standby Current	Standby Quiescent Current [†]	-	30	33	µA
Resistance	Turbo NFET Power-Path Resistance including PCB Parasitics, Excluding Current Sense	-	0.0046	-	Ω
	Current Sense Resistor	-1%	0.020	+1%	Ω
	RED, GREEN, BLUE low-output Series Resistance	20	-	50	kΩ
Efficiency	Maximum Overall Driver Efficiency	-	93.5	-	%
Frequency	Buck-Boost Switching Frequency	2200	2400	2600	kHz
	ATTINY1634 Clock Frequency	-10%	8000	+10%	kHz
	Control Frequency*	-10%	3.906	+10%	kHz
	Default Party-Strobe Mode Frequency*	-	21.7	-	Hz
	Default Tactical-Strobe Mode Frequency*	-	9.4	-	Hz
Timing	Turbo NFET Rise Time	-	1.0	1.25	ms
	Default Party-Strobe Mode On-Time*	-	8.5	-	ms
	Default Tactical-Strobe Mode On-Time*	-	34	-	ms
Temperature	On-board Temp Sensor Range	-40	-	125	°C
	On-board Temp Sensor Accuracy 0°C to 70°C	-	±1	±2	°C
	On-board Temp Sensor Accuracy -40°C to 125°C	-	±1	±4	°C
	Hardware Over-Temperature Shutdown	-	140	-	°C

* These values can be configured or changed in firmware options or during operation.

[^] Maximum output current limited by internal maximum pass-FET junction temperature and external power-path resistance.

[†] When external auxiliary RGB LEDs disabled. Standby current will vary depending on firmware used.

^{**} Value listed is for Buck mode operation; during Boost mode operation, maximum regulated current depends on input voltage, internally limited such that Boost switch FET current is maintained <4A.

4.4 Typical Characteristic Curves & Comparisons

The following efficiency curves compare total driver efficiency of the LUME1 driver with the stock linear FW3X driver (which uses 7 linear AMC7135 constant current regulators), across their operation range of regulated current capabilities.

Total driver efficiency was measured with input power supplied an Agilent E3633A bench power supply. Current measurements taken using a calibrated Tektronix TCP0030A Current Probe with a Tektronix MSO4104. The load LED was a single Cree XLamp XM-L2 LED connected to the output of the driver. The LED was connected to a large heat-sink. All tests were carried out at an ambient temperature of 22°C. Measured voltages used 4-wire sensing for accuracy.

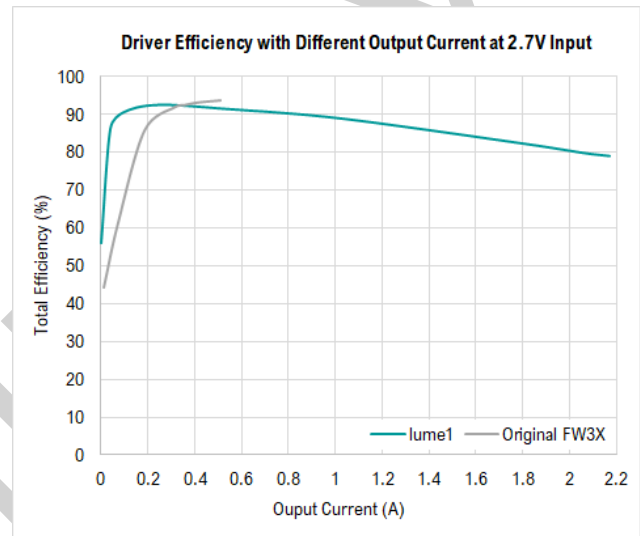
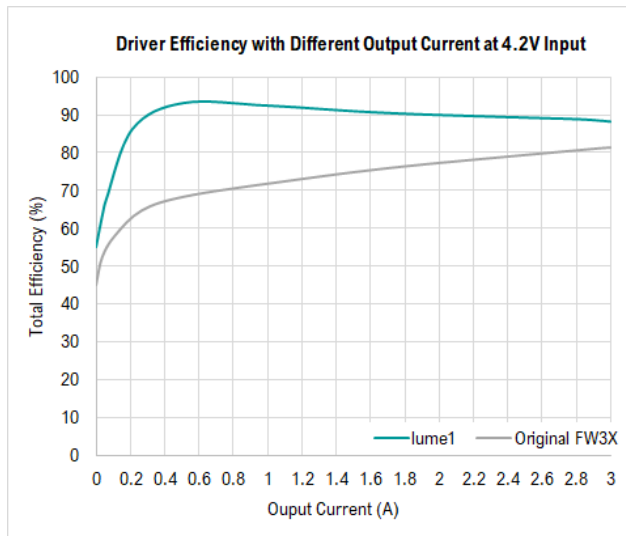

These efficiency curves demonstrate the benefits of a switching topology, where the LUME1 driver exhibits significantly higher overall efficiency especially at high input voltages. This efficiency difference will be even more significant when using low V_{FWD} LEDs, higher voltage batteries (such as newer cells charged to 4.35V), or when LEDs are used in parallel, such as in the FW3X flashlights.

As battery voltage drops, the maximum output current of the stock driver is limited. This is caused by the fact that as cell voltage drops, it begins to approach the forward voltage of the LED. The result is that maximum output current is significantly diminished.

Conversely, the LUME1 driver has Boost capability, and continues with a high regulated output current even when cell voltages drop below the forward voltage of the LED. In these scenarios, note that maximum regulated current may drop below 3A, due to internal over-current protection to limit Boost Switch current to 4A. This capability of the LUME1 driver enables a high regulated LED drive current at low cell voltages, which can be useful during situations such as low ambient temperatures when lithium battery voltages tend to drop.

5 Detailed Description

5.1 Overview

The LUME1-FW3X driver belongs to the LUME1 family of high-performance, regulated, constant-current, buck-boost drivers, with on-board direct-drive FET for Turbo. The LUME1 driver is fully integrated with an on-board current-regulated switching converter, a bypass NFET switch for maximum brightness mode, and improved thermal regulation over stock drivers.

With the use of a switching regulator, the LUME1 driver significantly improves flashlight driver efficiency. This is especially important in modern flashlights, where typical LEDs chosen have a very low forward voltage (close to 3.0V or even lower), and where new-chemistry lithium cells tend to operate at higher voltages (up to 4.35V). This is further exacerbated by multi-parallel LED flashlights such as the FW3X, where V_{FWD} is low even at high current drive. In worst-case scenarios, traditional linear-type drivers such as popular 7135-based drivers achieve <70% efficiency. In contrast, the LUME1 driver operates at over 90% efficiency over most of the output range, and markedly improves overall runtime over linear-type drivers.

Control of the subsystems in the LUME1 driver is handled via an ATMEL ATTINY1634 MCU operating at 8MHz. With 16KB of flash, 256B of EEPROM and 1KB of SRAM, the MCU can run popular open-sourced firmware such as Anduril. Control signals to the output blocks are nominally 10-bit PWM at 3.9kHz. This implementation allows 1024 levels of regulated output brightness, allowing for a very smooth LED brightness modulation. Since the LED output is current-regulated and not PWM modulated (which is different from the PWM control signals within the driver), LED flickering is eliminated.

5.2 Functional Block Diagram

Functional Block Diagram of the LUME1-FW3X.

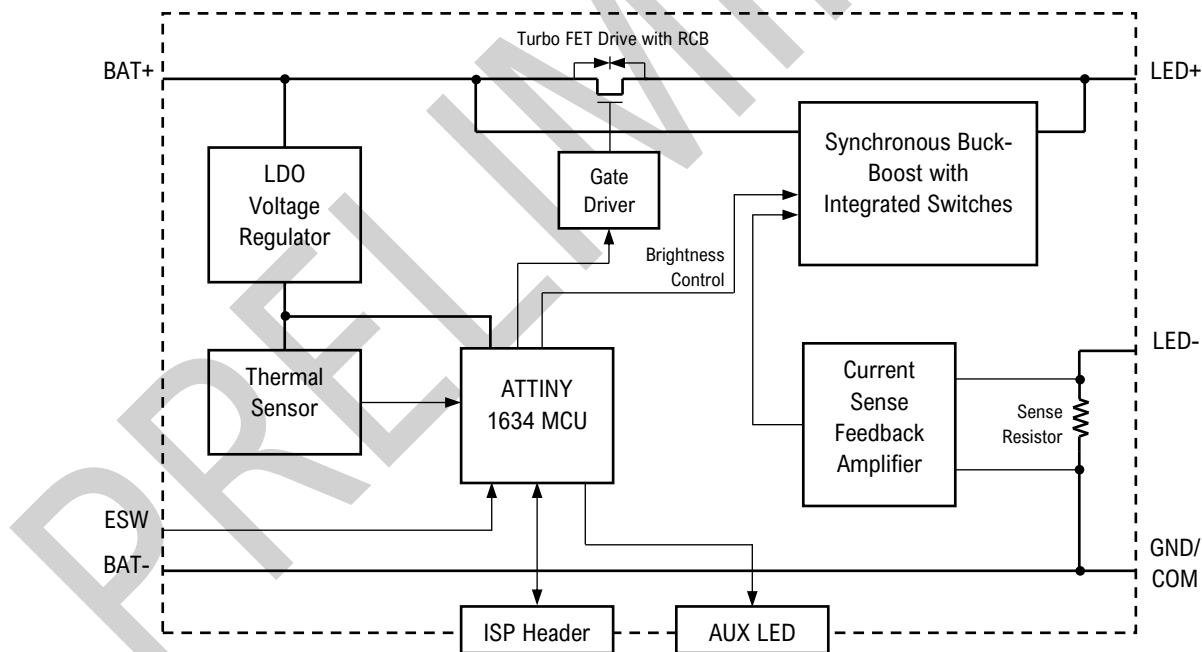

5.3 Feature Description

5.3.1. Constant Current Buck-Boost Mode

The switching regulator is implemented with a single-inductor 4-switch monolithic regulator with current-sense amplifier feedback via an on-board current-sense resistor. The on-board MCU determines a set current level and the buck-boost

regulator with current-sense amplifier regulates the output to achieve the desired output current limit. While the regulator will be operating in Buck mode for majority of expected use cases, the regulator transitions seamlessly to Boost mode when the input voltage falls below the forward voltage of the load LED. This feature enables a truly consistent regulated output regardless of battery voltage or during low ambient temperatures where lithium cells exhibit lower cell voltages.

The switching regulator operates at a nominal switching frequency of 2.4MHz, allowing external components to be kept small. During low output current levels where the average inductor current drops below 100mA, the switching regulator reduces switching frequency and lowers quiescent current to maintain high operating efficiency across the entire output range.

5.3.2. Direct Drive FET Mode

A popular feature of many flashlight drivers is a 'direct-drive' Boost mode, whereby the LED is directly connected to the cell with as low a resistance as possible. In practice, with proper thermal management, this allows extremely high LED output for short durations. The LUME1-FW3X implements this feature with two very low R_{dsON} N-Channel MOSFETs back-to-back, bypassing the switching regulator while in operation. To reduce R_{dsON} , the FET gates are driven with a dedicated FET driver block with integrated voltage multiplier to fully saturate the FETs. This implementation also protects against reverse current flow during Boost-mode operation.

5.3.3. Thermal Management

To protect the driver from overheating, an on-board thermal sensor is implemented. Thermal regulation is performed by an algorithm dictated by the MCU firmware and can be modified to suit the users' requirements. Thermal regulation adjusts the output current to attempt to keep the driver temperature at a user-configured temperature limit.

To further improve thermal management, the driver should be thermally well-coupled to the flashlight body and the main LED MCPCB (metal-core PCB). This is achieved by ensuring that the driver is correctly located within the driver cavity of the flashlight host, and the retaining ring tightened down with the appropriate torque. Additional thermal paste is not required. Instead, shelf contact area between the driver edge and the flashlight driver shelf should be cleaned carefully and deburred if required.

5.3.4. Low Voltage Protection

The LUME1 driver has built-in low voltage protection (LVP). The exact behavior is governed by the MCU firmware. Generally, LVP causes the driver to reduce output current to a lower current when the battery is low. When the output current reaches the lowest set current, the driver shuts itself off to prevent over-discharging the battery. This happens at 2.8V.

6 Application and Implementation

6.1 Typical Application & Installation

The LUME1 is designed to fit in the FW3X series of flashlights produced by Lumintop, including the FW3A, FW3C, FW3S and FW3T. It is intended to be a drop-in replacement. The LUME1-FW3X is not guaranteed to fit in any other flashlight, any future versions of the FW3-series flashlights, and the user is encouraged to ensure compatibility with the target flashlight.

6.1.1. Disassembly of FW3X Flashlight

The LUME1 flashlight is a drop-in replacement for the stock driver. To begin, disassemble the flashlight by removing the top assembly. No changes are required to the body tube or the tail assembly. Next, unscrew the front bezel of the flashlight. This will allow removal of the Carclo tri-emitter TIR optic. Take care to also avoid dropping the glass front lens. Next, desolder the main emitter LED wires. These two wires are connected to the L+ and L- pads on the MCPCB. Due to the high thermal conductivity of the MCPCB, it is recommended to use a small amount of solder flux and a high quality soldering iron to desolder the wires.

Then, the driver can be removed. Flip the front assembly over, and unscrew the brass retaining ring. This is mostly easily done with the appropriate snap-ring pliers, or needle nose electronics pliers. The driver is then easily removed. The LUME1 driver may or may not come with a spring attached. If it does not, simply desolder the spring on the stock driver, and transfer it to the BAT+ centre pad of the LUME1 driver. Likewise, the main LED wires can also be reused. Otherwise, the recommended wires to use for LED+ and LED- are AWG20 or AWG22 silicone coated multi-stranded flexible wire. The nominal length should be 10mm with tinned ends.

6.1.2. Preparation of Driver Cavity

One of the main features of the FW3X is its compact size. This is achieved by optimizing the mechanical design to be as compact as possible. However, a drawback is the very limited Z-height for the driver components. The tallest item on the LUME1 driver board is the inductor, measuring at 2.1mm tall, which just fits the driver cavity.

After the removal of the stock driver, examine the driver cavity to ensure it is free of debris. Typically, a small phillips-head screw is screwed directly into the LED shelf from the front of the flashlight. This hole for the screw can lead to some metal burrs around the tapped hole. It is recommended to remove this burr to prevent shorting out components on the LUME1 driver.

Flip the assembly to the LED-side. You should see a small screw at the edge of the MCPCB. This screw is not used to hold the MCPCB down, but rather, serves as an alignment pin to prevent MCPCB rotation when the bezel and optic are screwed on.

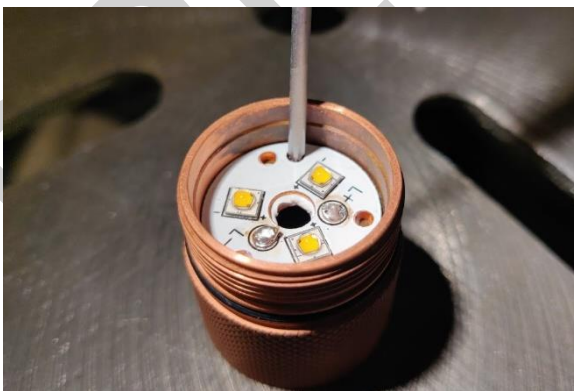

This screw is easily removed with a small screwdriver – there is no need to remove the LED MCPCB. Thereafter, flip the assembly back around, and the hole can be easily deburred with a sharp drill-bit of a larger diameter than the actual hole, as

shown above. Be very careful not to drill through the LED shelf – the goal is to create a very small bevel, to remove any burrs. When complete, clean the driver cavity as well as possible with isopropyl alcohol.

6.1.3. Installation of the LUME1 Driver

The installation of the driver is simply the reverse of the removal of the stock driver. The only key aspect to take note is with centering of the driver. Due to the design of the FW3X flashlight, the e-switch signal is conducted via a thin metal tube around the battery. This tube needs to make good contact with the ring-shaped ESW pad on the LUME1 driver. Ensure the driver is seated as centrally as possible before tightening the retaining ring down. If the tail-switch fails to work, check that the driver is seated correctly, otherwise the tube may not be in contact with the ESW pad, or may be shorting out ESW to GND.

6.2 Interfacing with External AUX LED boards

6.2.1. Choosing the Appropriate AUX LED Board

The LUME1 driver supports Auxiliary (AUX) LEDs. These LEDs can be configured in the user interface to do different things when the main emitters are off. For the FW3X, the LUME1 pairs well with a front-bezel AUX LED board. There are two different AUX LED boards designed to be compatible with the LUME1 driver – the RGB LED AUX board, and the Tri-LED AUX Board. These AUX LED boards are designed to be compatible with Carclo 10mm triple emitter TIR optics, specifically the 105xx-series (<http://www.carclo-optics.com/optics-for-leds/10mm/>), or equivalent Yajamei-brand Optics.

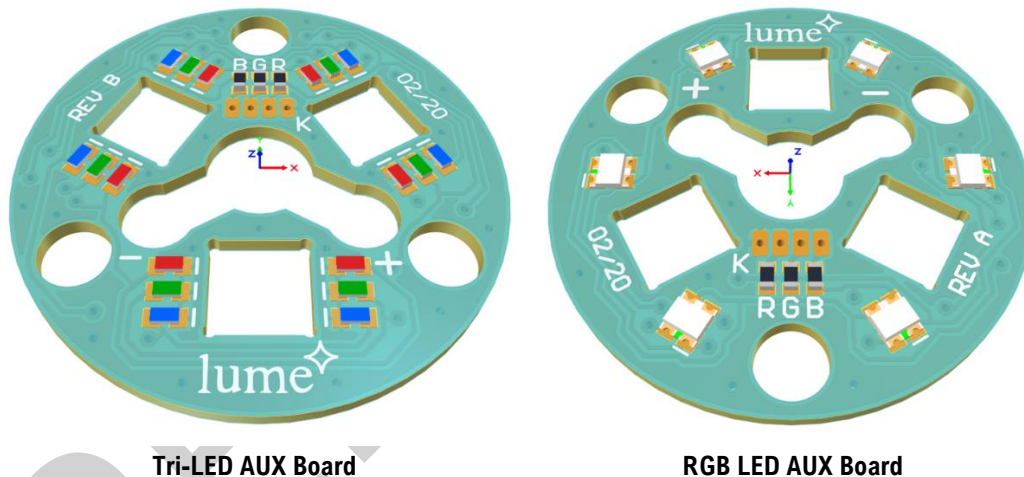

Note that the AUX LED board is purely optional and the LUME1 driver can operate without requiring any AUX LED board. There are two kinds of AUX LED boards – a Tri-LED board, or an RGB LED board. The Tri-LED features three arrays of six 0402 LEDs, allowing the user to customize the LEDs to any colour of their choice. The RGB LEDs allow the use of small RGB LEDs which have individual LED emitters placed very close together, allowing for colour mixing to achieve yellow, magenta, cyan and white colours.

The AUX LED boards should have a nominal PCB thickness of 0.8mm. 1.6mm boards may fit, but may require light sanding at the edges or drill holes to allow proper seating of the support legs of the Optic.

The Tri-LED AUX board is designed to hold three banks of six 0402 LEDs. Each bank of LEDs is configured in parallel with one 0402 series resistor per bank. All LEDs have their Cathode connected together, and are terminated on pad K. 0603 LEDs can also fit on the pads. The silkscreen line marks the cathode-side of each LED.

The RGB LED AUX board is designed to hold six individual 1615 RGB LEDs in Common Cathode configuration. Like the Tri-LED AUX board, these LEDs are connected in parallel with each bank of LEDs having a single 0402 series resistor.

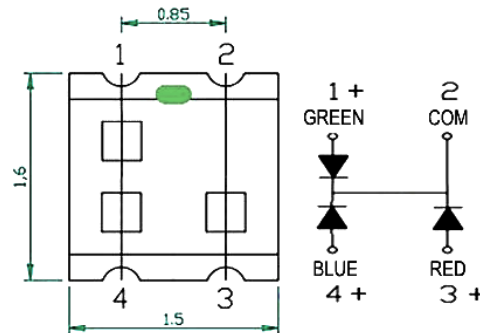

The LEDs designed to be used can be found [here](#). The LEDs used must have the pinout as shown above. Another alternative is the Kingbright APTF1616SEJ3ZGGVBDC. It can also be used but with the caveat that the GREEN and BLUE pins are swapped, and should be taken into account during assembly.

See Section 7.3.5 for information about customizing the brightness of the AUX LEDs by choosing the appropriate series resistor. See section 8.1.3 for information about LED AUX board files.

6.2.2. Installing the AUX LED Board

To enable support of the AUX LED Board, additional wires need to be soldered onto the RED, GREEN, BLUE and COM pads on the LUME1 driver. The recommend wire to use is 20mm of AWG30 Teflon-coated multi-stranded wire.

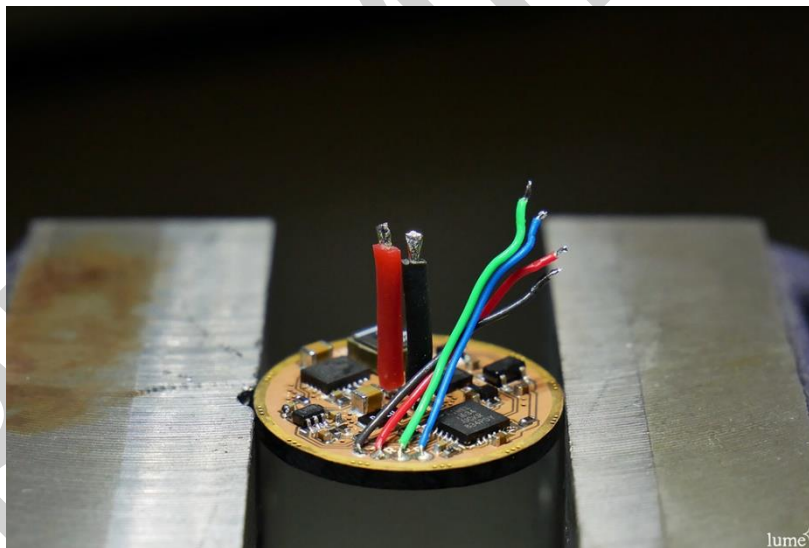

Wires can be soldered on like shown above. Take care to prevent shorts.

The additional 4 AUX LED wires are threaded through the centre hole of the LED shelf. After soldering on the main wires connecting the driver to the main emitter MCPCB, the AUX LED board is then lowered onto the MCPCB. Note that the main LED wires need to be soldered on carefully to fit within the Y cut-out of the AUX LED board.

In addition, ensure that the AUX LED board allows the Carclo TIR optic to sit well, and that the front bezel can be screwed closed after the AUX LED board is installed. It may be necessary to carefully sand the edges, or slightly bevel the three drill holes to allow the Carclo TIR optic legs to seat correctly.



Finally, the four wires are soldered onto the pads. The above photo shows an example of an assembled tri-LED AUX board in a FW3C. The wire connected to COM should be soldered into the pad labeled K on the AUX LED board; this pin is the common cathode of the 3 LED banks. RED, GREEN and BLUE is connected to R, G, and B respectively.

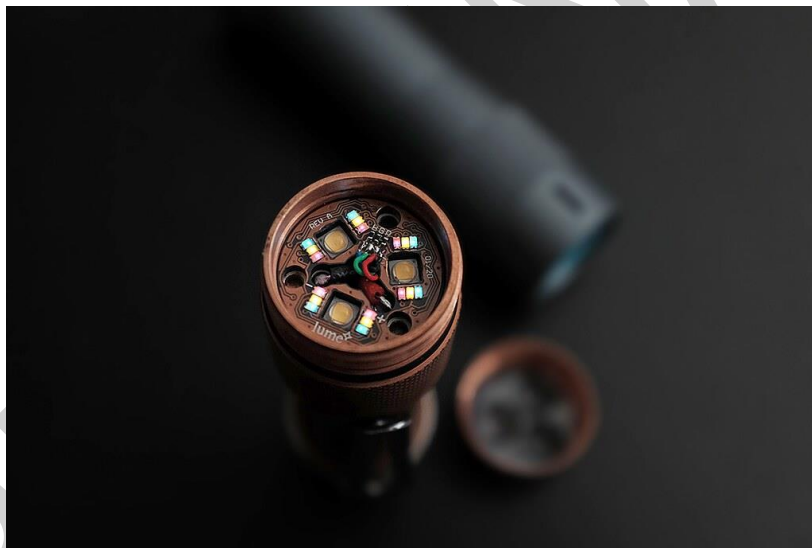

After installation, the AUX LEDs should illuminate by default when a battery is inserted. If the AUX LEDs do not come on, check that they are not disabled in the firmware – if they are, they can be easily re-enabled. See section 7.1 for instructions. Otherwise, ensure that the LEDs are installed correctly, and that the wires are soldered correctly.

7 Firmware and Driver Behavior

7.1 Anduril UI

The LUME1-FW3X driver was designed to be used with Anduril, an open-sourced, fully featured e-Switch User Interface. The firmware is developed and maintained by ToyKeeper together with the open-sourced hobbyist flashlight community.

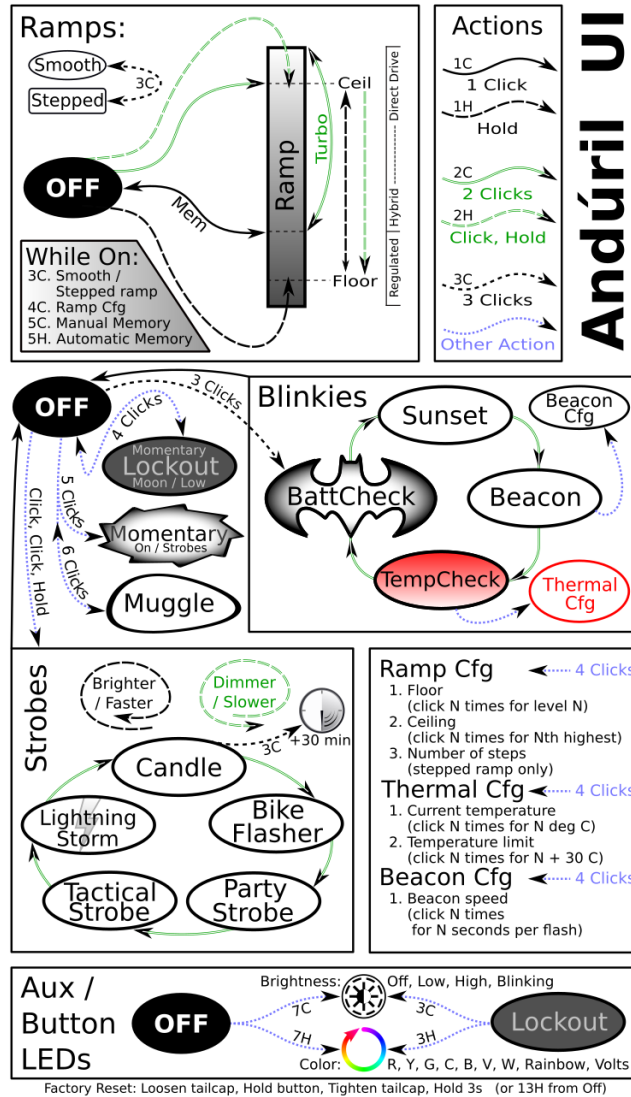

The above flowchart provided by ToyKeeper demonstrates the capabilities of the Anduril User Interface.

Anduril supports a huge range of features which are constantly evolving. Some of the highlight features are a smooth brightness-ramping functionality with mode memory, a wide range of strobe modes including candle-light, thunderstorm, and bicycle flash, as well as several utility functions including temperature and voltage read-out, and lock-out modes.

The LUME1 driver takes advantage of the wealth of features provided by Anduril. The full Anduril manual can be retrieved at <http://tiny.cc/TKAnduril>.

7.2 Firmware Flashing

Flashing of the firmware is done via Atmel's ISP interface with 6 pins, specifically, RST, GND, VCC, SCK, MOSI and MISO. The LUME1 driver implements the community-friendly 4:2 pogo-pin interface on the bottom (spring-side) of the PCB, allowing re-flashing of the driver even after installation into a flashlight. The recommended VCC voltage during programming is 3.3VDC.

The pogo-pin programmer can be built DIY using instructions from <http://budgetlightforum.com/node/63230>.

Alternatively, a programmer can also be purchased from Intl-Outdoors at <https://intl-outdoor.com/components-6/reflashing-kits.html>.

Latest firmware including required fuses to set for the ATTINY1634 can be found in Section 8.2.

7.3 LUME1-Specific Behaviour

The LUME1 driver implements a completely different topology to conventional linear drivers. As a result, there are some specific characteristics.

7.3.1. MOON Mode

The lowest output level is known as MOON mode and is designed to be used in very dark situations to avoid blinding the user. In the LUME1 driver, the lowest MOON mode may be slightly higher than some 7135-based systems, which achieve their lowest mode by a high frequency PWM of a single 7135 linear regulator. The LUME1 driver maintains constant current regulations all the way down to its lowest level of 1/1024 brightness. It is possible to reduce this even further, but the switching regulator goes into a pulse frequency modulated mode for improved efficiency, leading to a visible ~100Hz flicker. In fact, at lowest MOON modes, a slight 'PWM' of around 1kHz is present due to the switching regulator, to improve converter efficiency. This was deemed to be a suitable trade-off since this high frequency flicker is almost imperceptible, generally unobtrusive, and quickly vanishes at any higher brightness levels.

7.3.2. TURBO Mode

TURBO mode is implemented like many conventional LED flashlight drivers, via a direct-drive FET. However, in the LUME1 driver, the current path goes through a current sense resistor, adding 20mR to the current path. This slightly reduces the absolute possible maximum brightness, but was deemed a reasonable trade-off since this marginally benefits some very low V_{FWD} LEDs which may be used with this driver, and can actually burn with more common FET drivers. The rest of the LUME1 driver power-path is current-optimized.

7.3.3. Low Battery TURBO Scenario

When the battery used to power the LUME1 driver is low (e.g. 2.9V), it is possible for the LED forward voltage to be higher than the cell voltage at certain output currents. In such scenarios, it is possible for the maximum regulated LED current to be higher than direct-drive TURBO, because the LUME1 driver can operate in Boost mode. This can result in 'Turbo' brightness being lower than maximum ramping brightness.

7.3.4. FET PWM

The LUME1 uses a 10-bit 3.9kHz PWM control signal for both Constant Current level control and FET control. Due to the design of the driver, the FET driver has a rise time of approximately 1.25ms. As a result, PWM of the FET is not recommended. By default, the LUME1 driver implements FET drive only in TURBO mode (i.e. only fully ON or fully OFF and with no PWM).

7.3.5. AUX RGB LED Output

The LUME1 driver is capable of interfacing with an external auxiliary RGB or tri-LED board, typically used to illuminate a switch or the front bezel of the flashlight. However, the LED driving voltage in the LUME1 driver is 2.5V. This is a little lower than usual, and typically a little experimentation is required to decide the correct resistor value for the LEDs used on the AUX LED

board. For example, blue LEDs with higher V_{FWD} than red LEDs will require a much smaller value resistor. The user is encouraged to try different values to suit their needs.

7.3.6. Soft Factory Reset

As of writing, soft factory reset is not yet possible due to the eSwitch being disconnected when the flashlight is unscrewed, unlike other eSwitch flashlights. This may be supported with future firmware upgrades. Otherwise, the driver can be reflashed via pogo-pins.

PRELIMINARY

8 Support Resources

8.1 Product Support

For more information about the LUME1-FW3X and LUME1 family of flashlight drivers, please visit www.loneoceans.com/labs/.

8.1.1. Driver Revision

As of April 2020, the latest LUME1-FW3X driver version number is REV B.

8.1.2. Firmware Version

Please refer to the driver firmware repository in section 8.2 for the latest firmware version and revisions.

8.1.3. AUX LED Boards

Latest LED AUX board files can be downloaded at <https://oshpark.com/profiles/loneoceanslabs>.

8.2 Firmware Support

The LUME1 driver is designed to support open-sourced community firmware. The recommended firmware for the LUME1-FW3X is Anduril by ToyKeeper. Latest firmware for the driver can be pulled from the following repositories:

- For Windows Environment (Atmel Studio 7) <https://github.com/loneoceans/lume1-fw3x-anduril/>
- For UNIX Environments <http://tiny.cc/TKAnduril>

Firmware support is maintained by the open-source flashlight community. Changing the firmware may affect performance of the LUME1 driver and its electrical characteristics.

8.2.1. ATMEL ATTINY1634 Fuses

The recommended fuses for the internal ATTINY1634 MCU are as follows:

LOW	0xE2 for 64ms startup delay and 8MHz internal oscillator
HIGH	0xDE for 1.8V Brown-out-Detection
EXTENDED	No change from Defaults

These are subject to change; please refer to the latest firmware revision for most updated values.

8.3 Community Support

The LUME1 driver was developed with the suggestions and feedback of the BudgetLightForum flashlight hobbyist community. Information about this driver development can be found at <http://budgetlightforum.com/node/71616>. Many thanks to the community members for the invaluable feedback, suggestions and comments.

8.4 Electrostatic Discharge Caution

The LUME1 driver is intended to be installed in a compatible FW3 driver host and has limited built-in ESD protection. Before installation, the device should always be placed in conductive foam or an ESD-bag during storage or handling to prevent electrostatic damage to sensitive ICs and silicon devices on the driver.



IMPORTANT NOTICE AND DISCLAIMER

This datasheet is provided as a useful resource intended for skilled developers using the product outlined in this datasheet. This design resource, along with reference designs and other referenced resources are provided 'as is'. You are solely responsible for ensuring safety and compatibility of using this product and ensuring that its application meets applicable standards for safety, performance, and other requirements. These resources are subject to change without notice, and you will be fully responsible for any damages, losses, liabilities and costs associated with the use of these resources and the implementation of the product described in this resource.

PRELIMINARY