

MORTISE EDITION



LOCKLY **SECURE LUX**

INSTALLATION MANUAL

INSTALLATION OVERVIEW

Door

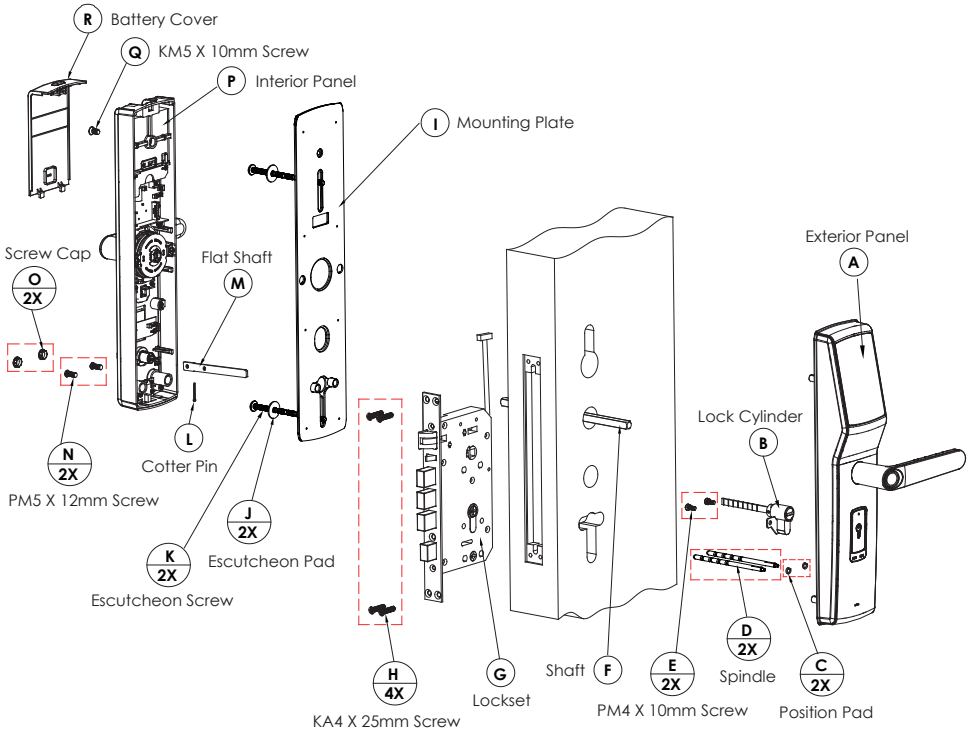

Door Frame

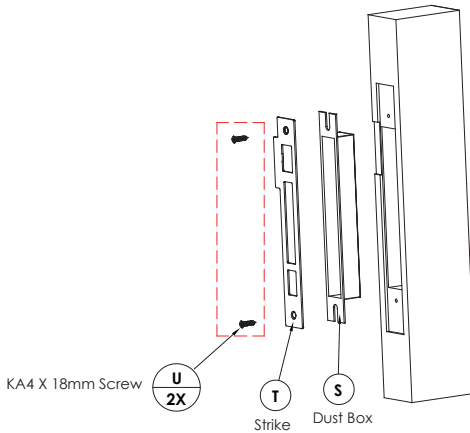

PARTS LIST

40~120mm Standard Door Thickness



T

Strike(X1)



S

Dust Box(X1)



M

Flat Shaft(X1)

Cotter Pin through here when door thickness is larger than 70mm
Cotter Pin through here when door thickness is less than 70mm



F

Shaft(X1)

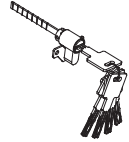

B

Lock Cylinder(X1)



C

Position Pad(X2)



H

KA4 X 25mm Screw(X4)



U

KA4 X 18mm Screw (X2)



O

Screw Cap(X2)



J

EscutcheonPad(X2)



E

PM4 X 10mm Screw(X2)



Q

KM5 X 10mm Screw(X1)



N

PM5 X 12mm Screw (X2)



V

Positioning Sleeve(X1)



L

Cotter Pin(X1)



Cut at this point when door thickness is bigger than 40mm and less than 53mm.
Cut at this point when door thickness is bigger than 53mm and less than 66mm.
Cut at this point when door thickness is bigger than 66mm and less than 79mm.
Cut at this point when door thickness is bigger than 79mm and less than 92mm.
Cut at this point when door thickness is bigger than 92mm and less than 105mm.

K

Escutcheon Screw(X2)



Cut at this point when door thickness is bigger than 40mm and less than 55mm.
Cut at this point when door thickness is bigger than 55mm and less than 70mm.
Cut at this point when door thickness is bigger than 70mm and less than 85mm.
Cut at this point when door thickness is bigger than 85mm and less than 100mm.

D

Spindle(X2)



W

Wrench(X1)

KNOW YOUR DOOR

There are 4 common door-opening directions, the lockset configuration as shown on each diagram below corresponds to the respective door-opening direction.

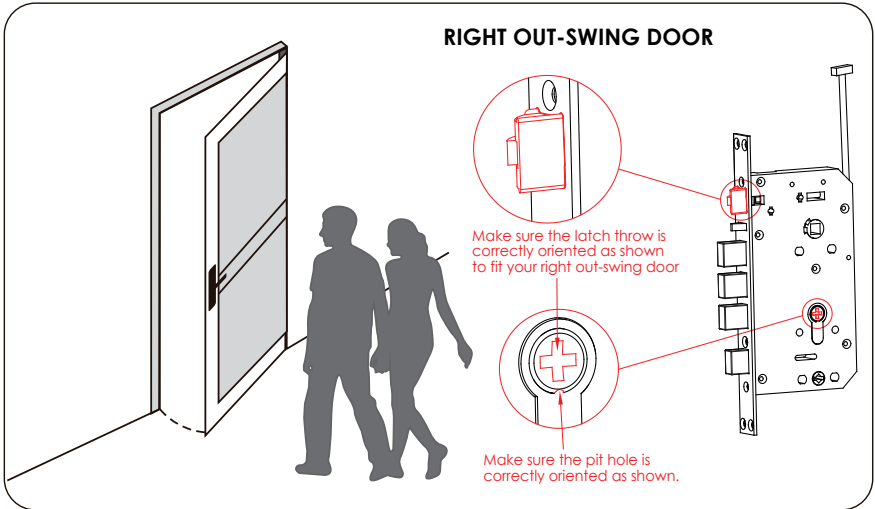
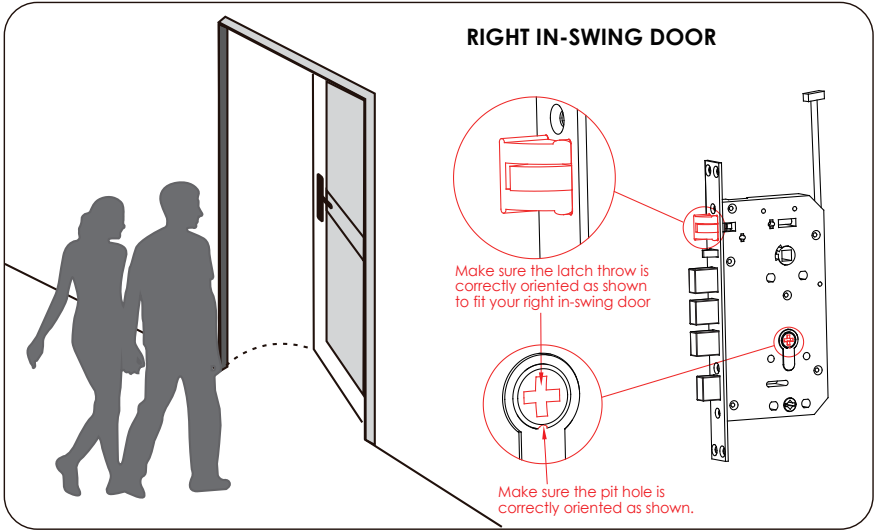

KNOW YOUR DOOR

LEFT IN-SWING DOOR

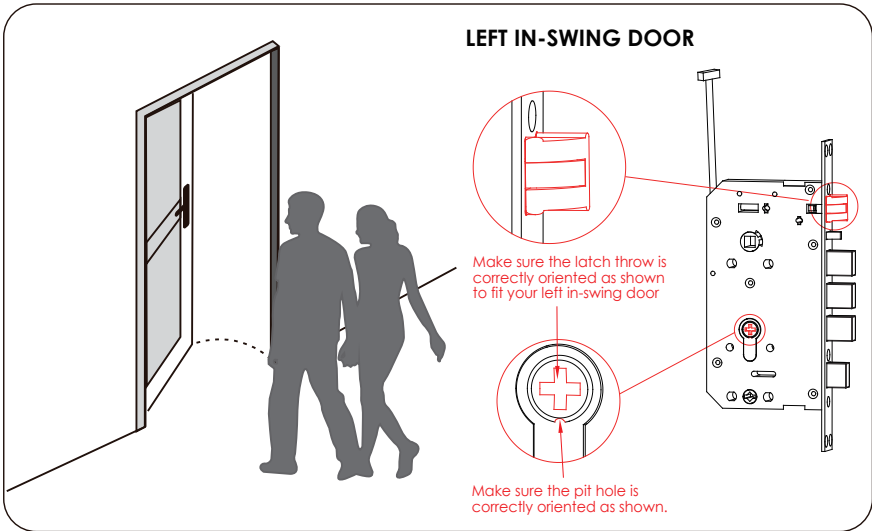

The diagram shows a left in-swing door with a person and a woman walking towards it. A callout shows the latch throw on the door edge, which is oriented to the left. Another callout shows the pit hole on the lock cylinder, which has a cross symbol and is oriented to the left. A third callout shows the lock body with the latch throw and pit hole components highlighted.

Make sure the latch throw is correctly oriented as shown to fit your left in-swing door

Make sure the pit hole is correctly oriented as shown.

LEFT OUT-SWING DOOR

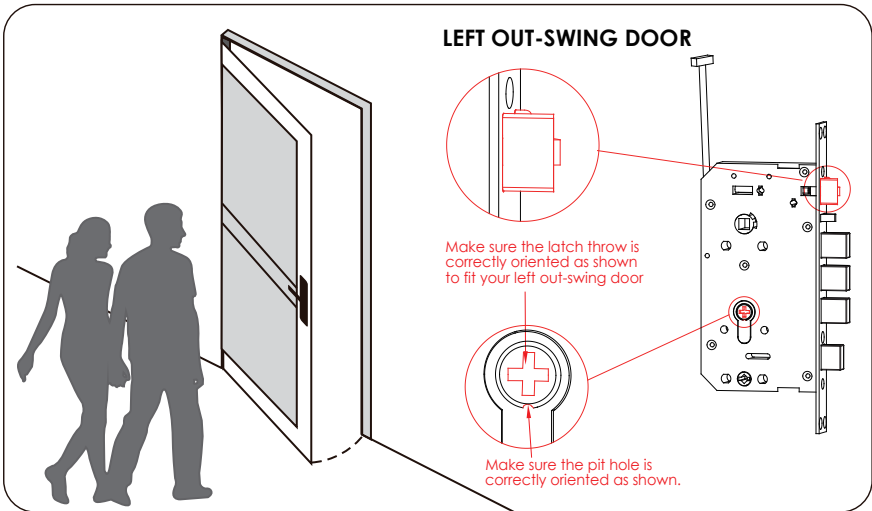

The diagram shows a left out-swing door with a person and a woman walking away from it. A callout shows the latch throw on the door edge, which is oriented to the right. Another callout shows the pit hole on the lock cylinder, which has a cross symbol and is oriented to the right. A third callout shows the lock body with the latch throw and pit hole components highlighted.

Make sure the latch throw is correctly oriented as shown to fit your left out-swing door

Make sure the pit hole is correctly oriented as shown.



IMPORTANT

Before installation, determine the door opening direction and adjust the lock body (latch throw and cylinder), the interior and exterior panels door handles accordingly. Instructions on how to adjust these parts are provided on the next pages.

HOW TO ADJUST THE LATCH THROW

Here is how to change the latch throw direction. The factory setting of the throw is for right in-swing door. You do not need to change direction if you have a right in-swing door.

1. You need a Phillips screwdriver.

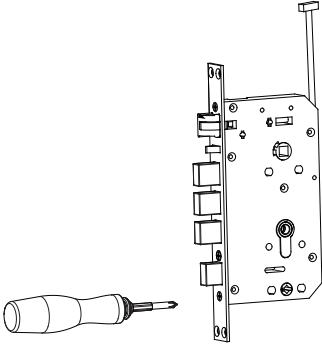

2. Unscrew the strike plate then turn the latch throw by 180 degree.

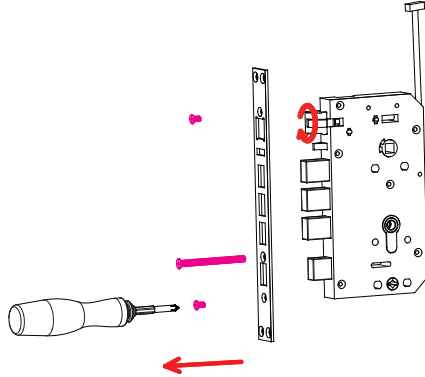

3. Turn the latch throw by 180 degree.

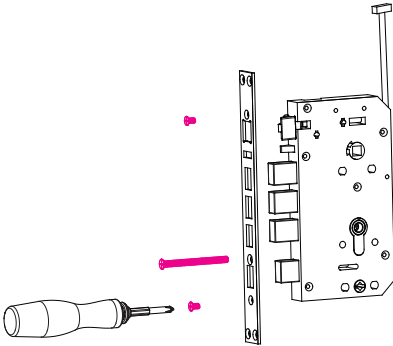

4. Fix the strike plate with mounting screws.

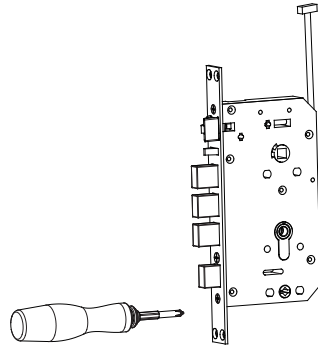

HOW TO ADJUST THE CYLINDER

Here is how to change the cylinder direction. The factory setting of the cylinder is for right in-swing door. You do not need to change direction if you have a right in-swing door.

1. You need a Phillips screwdriver.

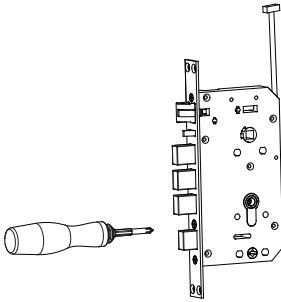

2. Unscrew the strike plate and take out the spin as shown then turn it to the reverse side of the lockset.

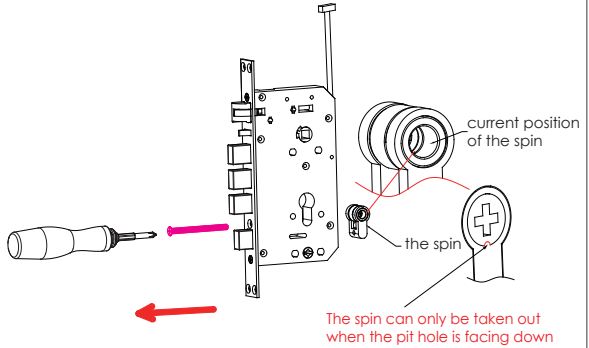

3. You must have the cross slot of the spin facing this side.

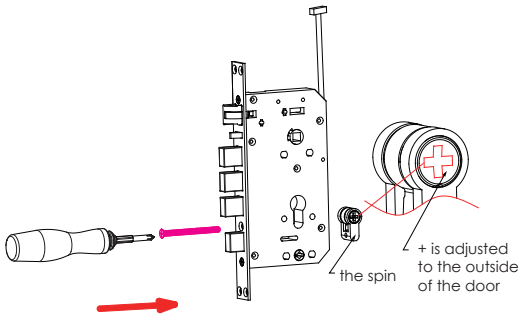

4. Fix the strike plate with mounting screws.

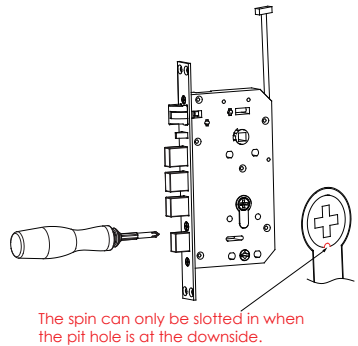

HOW TO ADJUST THE DOOR HANDLE

*The diagram below shows how to shift the door handle from right to left direction. The factory setting of the handle is for right handed door. You do not need to change direction if you have a right handed door.

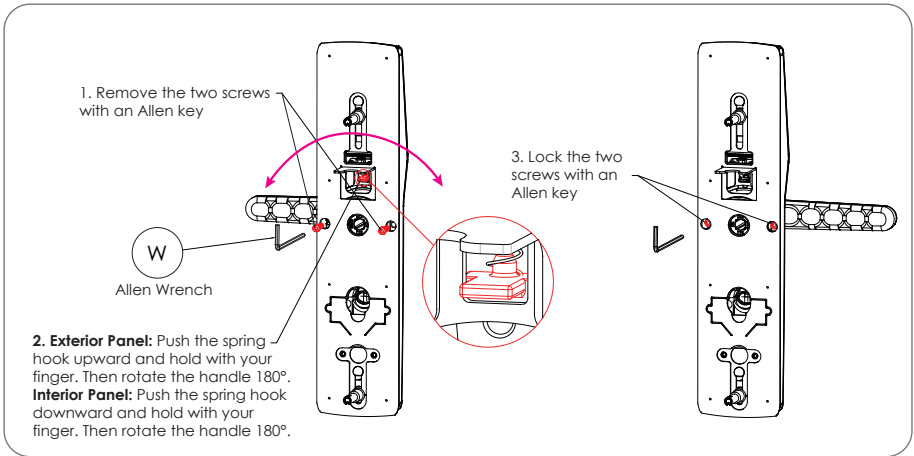

STEP 1: PREPARING YOUR DOOR

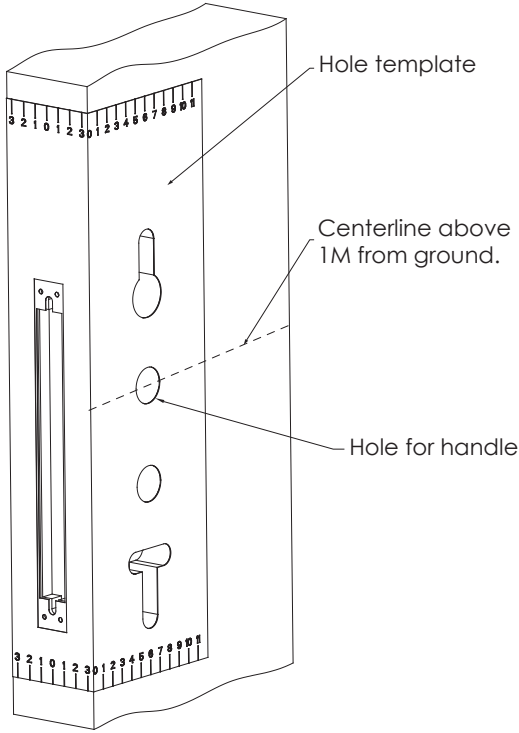

Make sure your door is prepared for installation. You may need to drill a new hole. Please use the supplied template for drilling holes required before installation. You will need some tools or a hole-saw.

STEP 3. INSTALLING THE LOCK CYLINDER AND THE SPINDLE

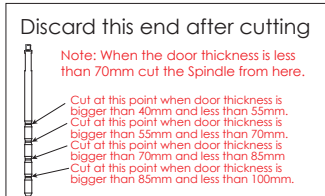
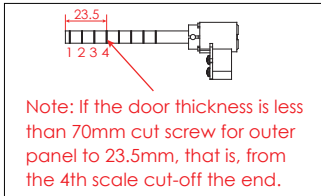
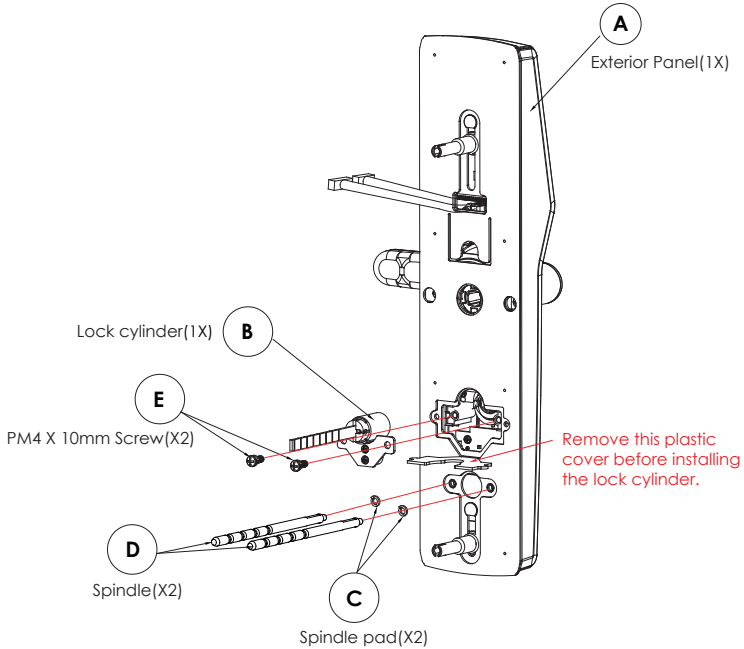

Make sure the lock cylinder is aligned with the door holes then fix it with 2 screws to the exterior panel. Consequently fix the two spindles and the spindle pads as shown with pliers.

STEP 4. INSTALLING THE EXTERIOR PANEL

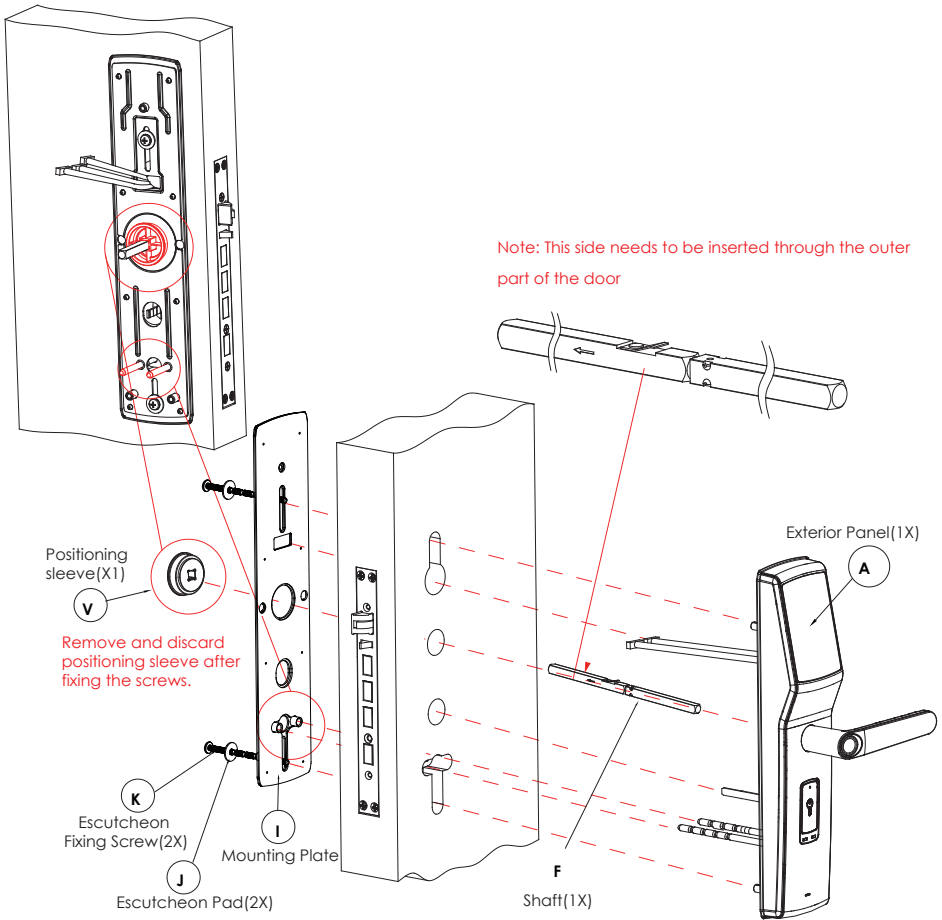

How to cut the shaft

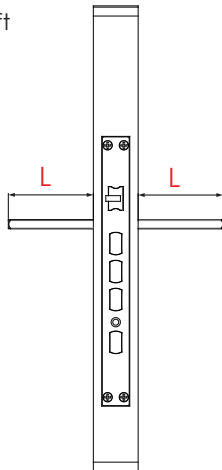

Note: Insert the shaft through the door. The "L" sections as shown in the diagram should be kept within 33-35mm. Cut and discard the excessive portion, if applicable.

Shaft Installation

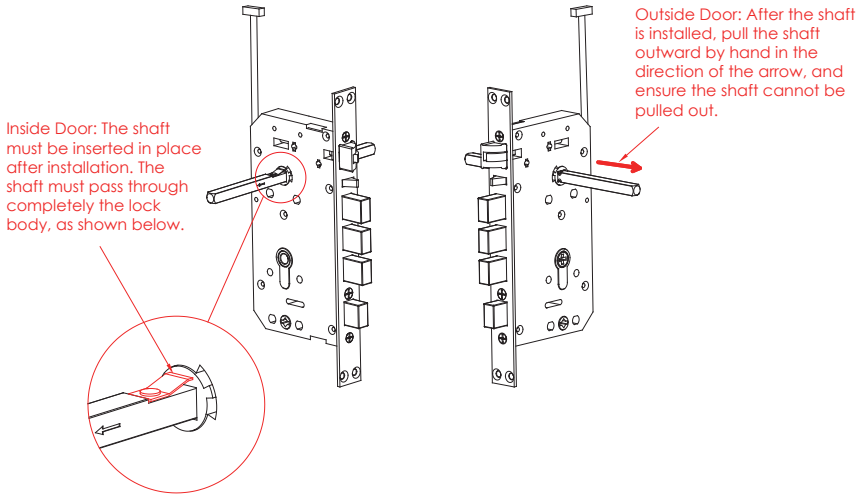

- 4.1** Insert the square shaft through the exterior panel. Cut the shaft according to the door thickness. Then install the exterior panel, shaft, EVA and the escutcheon in place.
- 4.2** Route both the lockset and exterior panel cables through the corresponding holes then insert the positioning sleeve into the inner side of the square shaft. Make sure they are all aligned and correctly oriented.
- 4.3** Check both inner and outer handles if they are in smooth operation. Then check if the locking and unlocking operations are smooth. If not, adjust the mounting screws until the the operation is running smooth. See illustration as shown below:

STEP 5 . INSTALLING THE INTERIOR PANEL

Remove and discard the positioning sleeve then insert both lock cables to the corresponding socket of the interior panel. Insert the cotter pin to the flat shaft. See notes as illustrated in the diagram. Then insert the flat shaft to the corresponding holes and tighten with screws provided.

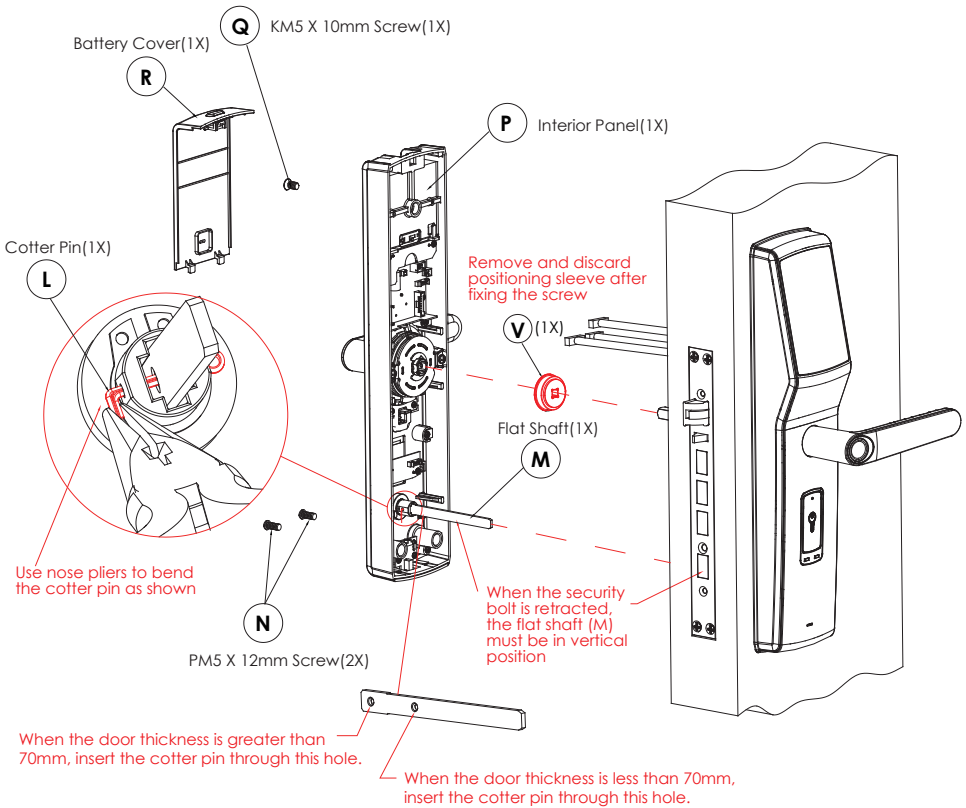

STEP 6. FINAL CHECK

After installation is completed, lift both the interior and exterior handles up and down making sure they are running smoothly. Then check if the deadbolt and strike plate is thrown smoothly with the physical keys.

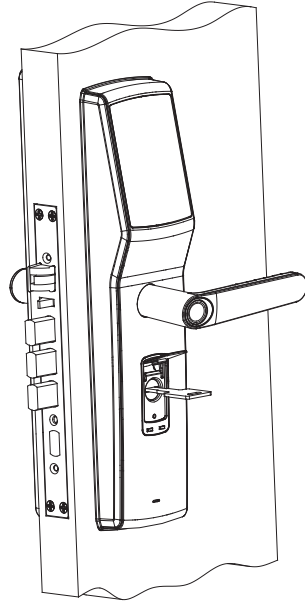

STEP 7. INSTALLING BATTERIES

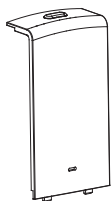
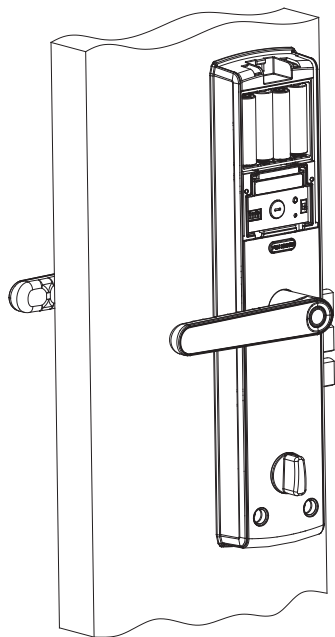

Check the functions of the lock per user manual after installing the batteries. Make sure the batteries are correctly positioned. Then close the battery cover.

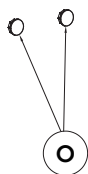

Screw Caps(2X)

STEP 8. PREPARING THE DOOR FRAME AND MOUNTING PLATE

Install the dust box as shown below. Open the door frame, install dust box, then the strike plate and fix it with screws.

When installing to a wooden door, cut the dust box as shown. No need to cut when you have a metal door.

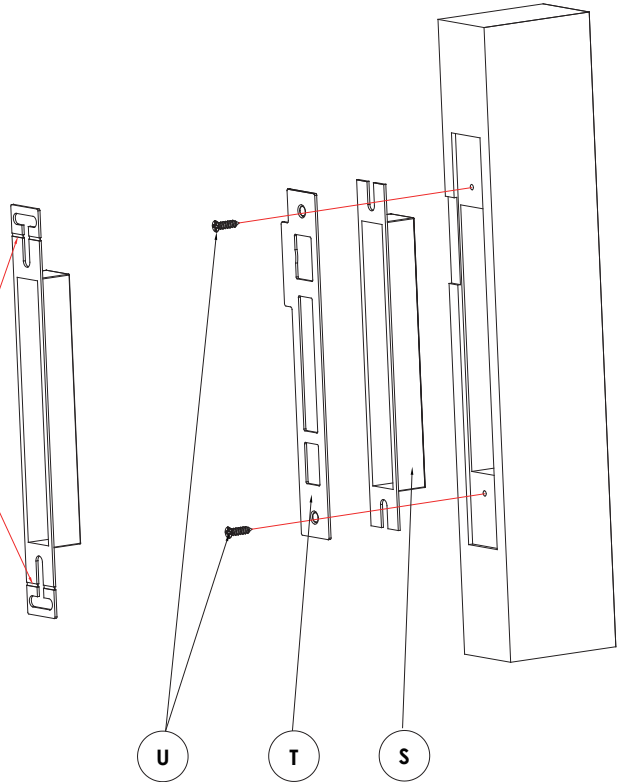

KA4 X 18mm Screw(2X)

Strike(1X)

Dust Box(1X)



For an online version of this installation guide and videos, visit:

<http://lockly.com/help>

