



USER MANUAL

ANY PROBLEMS, please contact us by Email.

Here is the address:

US Customers: q1support-us@peztio.com

EU Customers: q1support-eu@peztio.com



Scan to get the E-Instruction

DASH CAM

WIFI Connected

Full HD 1080P Wide Angle

INTRODUCTION

Welcome to use PEZTIO DASH CAM. This is Model, which equipped with WIFI function. Automatic start to record, just plug and play, video files will be saved on the memory card. Connect it to your cell phone though WIFI and check the videos on your phone album.

POWER SOURCE

Use car charger (5V 1A) to get power from cigarette lighter. Need to keep the power on to ensure the normal use.

WARNING:

Please keep the DASH CAM plugged into the power, plug and play it. This is a small capacity battery. It will automatically shut down after 10 seconds when the disconnect power.

MAIN FUNCTION

1. Build-in WIFI

Transfer your dash cam recordings to your smartphone or tablet over Wi-Fi using an app interface. This makes it easier than ever to share footage from your trips.

2. Loop Record

The Loop recording video can auto delete the old file on the SD card and save the new video. We recommend you the turn on the loop recording function, in case the SD card getting full soon and unable to save the new video.

3. Emergency Record

Parking Mode: When the Parking Mode is on, it will detect whether there is the moving object, and the recording will auto on for 10-20 seconds if it finds a moving object.

4. SOS mode

Press the **SOS button** to Lock the video currently being recorded. (If you set the loop recording time as 3 mins, when you press the SOS button, the dash cam will lock the video currently being recorded. The length of this locked video file is 3mins. The next loop recording period begins, and next video will not be locked)

PRODUCT STRUCTURE

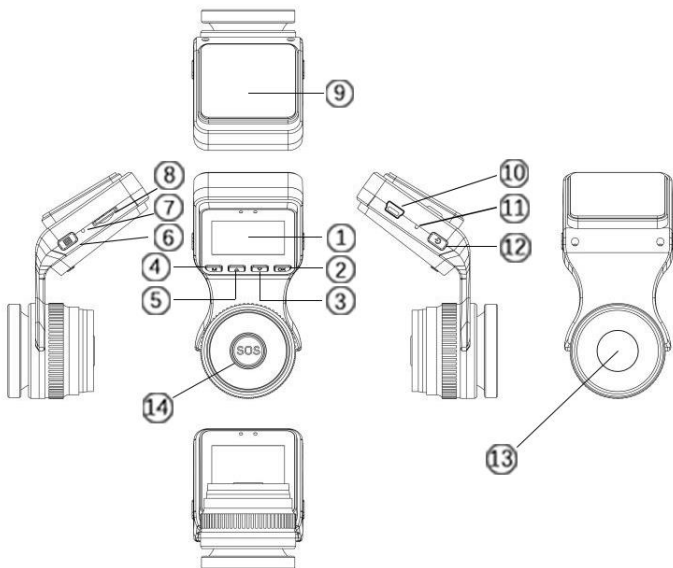

No.	Name	Description
1	LCD Screen	1.5" TFT Color LCD Display.
2	OK Button	Confirms the action; Stop/Start the video recording.
3	Down Button	Move selector up; rewind
4	Mode Button	Convert the modes.
5	Up Button	Move selector down; fast forward
6	Menu Button	Enter/exit setup menu
7	Microphone	Records clear audio with the video footage.
8	Micro SD Card Slot	Provides expandable storage (up to 32GB, Class 10)
9	Sticker	Fix it on the front windshield
10	Mini USB Slot	USB port for charging or transferring data.
11	Reset slot	Press to force reset the device.
12	Power Button /WIFI Key	Power ON/OFF WIFI ON/OFF
13	Front Camera Lens	Front Facing Camera for video recording road events.
14	SOS button	Lock current videos.

SCREEN OVERVIEW

Video Mode

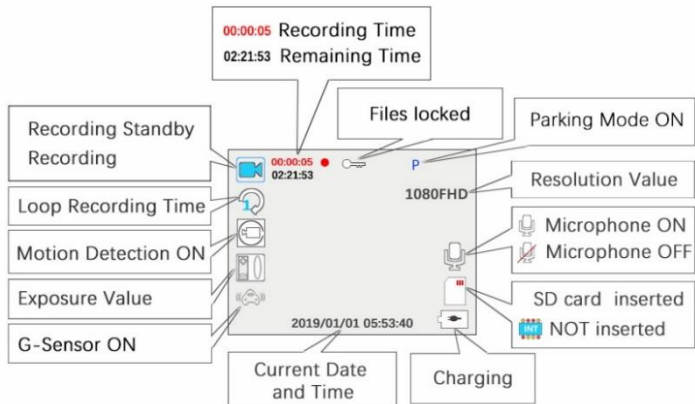
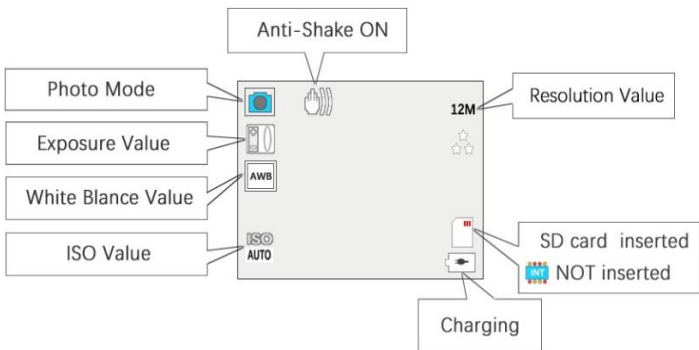
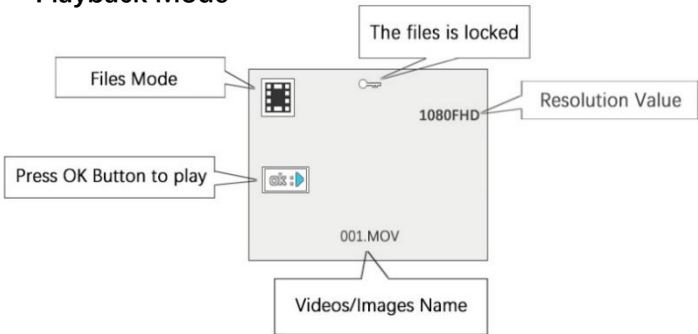

Photo Mode



Playback Mode



START TO USE

1. Install the memory card.

Note: Please choose a good quality branded SD card between 8GB and 32GB (Class 10 or UHS type 1) and format the card within the setup menu before use. Please insert the card in the right direction.



2. Ensure the Mini USB Cable and Car Charger are well connected.

3. Attach the dash cam to the front windshield

-Clean the front windscreen.

-Remove the protect sticker and attach it to the front windshield.

-Connect the charging cable to the cigarette lighter.

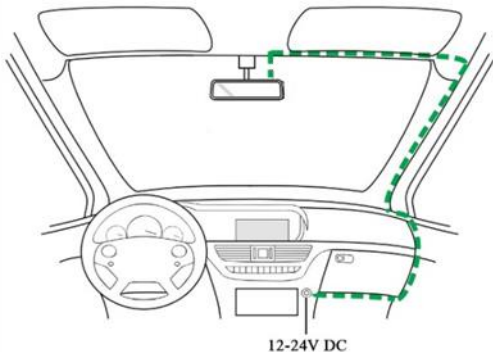

WIFI MODE

Start to use wifi mode

1. Download the GoPlus Cam app in smartphone.

IOS : search "**goplus cam**" in App Store.

(Support iPhone and iPad for iOS 8.0 or higher)

Android: search "**goplus cam**" in Play Store.

(Support for Android 4.0.3 or higher)

2. After booting up, in the case of no recording, press the power button, the screen displays WiFi is on, **WIFI name (SSID)**, **WIFI password (PWA2)**



Scan the code watch the WiFi operation video.



3. Open the smart phone WIFI and search for the device in the WIFI network.
4. Enter the **password (12345678)** for the first connection.
5. Wait for the phone to connect properly.
6. Once the connection is complete, run the APP: Goplus

GoPlus Cam app usage

Connect to WIFI, enter the Goplus APP.

1. Click to take photos/videos,
2. Download photos and videos files. You can check the photos/videos in your phone Album.



System Setting

Audio ON/OFF

Videos/Photos Files

Disconnect WIFI

Press to Record/Capture

Change Record/Capture

WIFI TROUBLE SHOOTING

PROBLEM	SOLUTION
My phone has searched the WiFi of the dash cam but unable to connect?	<ol style="list-style-type: none">1. Make sure no other device or phone is connected to the dash cam WiFi. The dash cam does not support connection with multiple devices at the same time.2. Disconnect the Wifi and reconnect again.3. Please restart your phone and try again.4. Reset the dash cam if the above step does not work.
It takes a long time to download a video.	The dash cam produce MPEG format video, which is a larger size format and have better quality video, so it takes minutes to download.
Must I download the videos to my phone? Can I check them directly?	Users of the IOS system can play back the video directly. The Android system user cannot directly play back the video, and the video needs to be downloaded to the mobile phone.
I can't connect the internet when I connect this WiFi?	This WiFi is only used for data transfer of dash cam and mobile phone, it can't access the Internet.
The connection is jumpy.	The distance between the phone and the dashcam is too far. It is the best to connect within 3m/9.8ft.

Why the videos are not clear when I check them from phone screen?	<p>Due to the limitation of WiFi transmission rate, the videos you watch is only 480P if you don't download the album.</p> <p>So, we suggest you download the videos to your phone and watch them in Album. The downloaded video resolution can be up to 1920*1080.</p>
How to reset Wifi password?	You can change the wifi ssid and wifi password in setting.

SETTING

System Setting

Content	Option
Parking Mode	ON/Off
Date/Time	Value
Auto Power Off	Off/1Minute/3Minutes/5Minutes
Screen Saver	Off/1Minute/3Minutes/5Minutes
Beep Sound Off	Off/On
Language	English, Chinese, Japanese , etc.
Frequency	50Hz/60Hz
WIFI SSID	GPLUSPRO
WIFI PASSWORD	12345678
LICENSE PLATE STAMP	Value
LICENSE PLATE STAMP	Off/On

SWITCH	
FORMAT Cancel	Cancel/OK
DEFAULT Cancel	Cancel/OK
VERSION	Value

Record Mode Setting

Content	Option
Resolution	1080P FHD 1920*1080/ 720P 1280*720
Loop Recording	Off/1Minute/3Minutes/5Minutes
WDR	On/OFF
Exposure	Value
Motion Detection	On/Off
Record Audio	On/Off
Date Stamp	On/Off
G-sensor	Off/ High /Medium/Low

Photo Mode Setting

Content	Option
Resolution	12M/10m/8M/5M/3M/2MHD/1.3M/VGA
Sequence	On/Off
Quality	Fine/Normal/Economy
Sharpness	Strong/Normal/Soft
White Balance	Auto/Daylight/Cloudy/Tungsten/Fluorescent

ISO	Auto/100/200/300/400
Exposure	Value
Anti-Shaking	On/Off
Date Stamp	On/Off

Playback Mode Setting

Content	Option
Delete	Delete Current/ Delete All
Protect	Lock Current/Unlock Current/Lock All/ Unlock All

TROUBLE SHOOTING

PROBLEM	SOLUTION
Can't record for 24 hours.	To achieve 24 hours record, please purchase a hardwire kit individually which is not included in the package.
The camera keeps reboot/ stop recording after few days	When there is not enough space in the SD card, the camera will stays rebooting, please format the SD card via the dash cam or your computer. Meanwhile, please check it the power cable is firmly connected to the dash cam and the cigarette lighter port.
The date & time can't be saved.	Please charge the dash cam for 15 minutes, then adjust the date & time again, the camera may has no enough battery to save the settings.

<p>I can only record a few minutes of videos on my memory card.</p>	<p>Format the SD card because your SD card is full of videos which is locked by the G-sensor and loop recording can't overwrite them. To format the SD card > Double press the menu button > Select the "format" then process</p>
<p>The screen's size is too small can't see everything clear.</p>	<p>To achieve the discreet design, the screen has limited size, please connect the dash cam with your cellphone to watch the full-size video</p>
<p>The screen goes blank and buttons don't work?</p>	<p>Please keep the dash cam connecting the power and use a needle to push the reset key of the dash cam, when the dash cam successfully reboots, it will work again. Note: Don't press any key during the dash cam is powering on, it will cause this issue again.</p>
<p>Video Image is blurred.</p>	<p>Remove the protective lens cover, clean the lens, clean the windscreen!</p>
<p>The screen blanks after a few minutes.</p>	<p>The screen saver is set to ON. Change settings to OFF if required. Default setting is off.</p>
<p>I can't delete files on my SD card.</p>	<p>Check to see if these files are 'protected', if so, please follow instructions to 'un-protect'.</p>
<p>Unresolved issues.</p>	<p>Reset the DASH CAM to the default settings within the Setup Menu and try again. Should the problem persist contact us by support e-mail.</p>

The screen blanks after a few minutes.	The screen saver is set to ON. Change settings to OFF if required. Default setting is off.
The SD card cannot be read.	Use a good quality branded SD card between 8GB and 32GB (Class 10 or UHS type 1) and format the card within the Setup menu.
The battery only last 10 seconds.	This battery can only reserve limited power. Plug and play it. Based on the design of power-off protection, the battery needs to reserve a part of power to support emergency recording function.
Not buttons available	When the camera is recording, the other buttons are unavailable to protect the dash cam file, please stop recording before you want to use the button to operate the camera. (Press OK to stop).

**We provide 12-month warranty for you,
ANY PROBLEMS, please contact us by Email.**

Here is the address:

US Customers: q1support-us@peztio.com

EU Customers: q1support-eu@peztio.com