

INSTRUCTION MANUAL

ICE CREAM MAKER

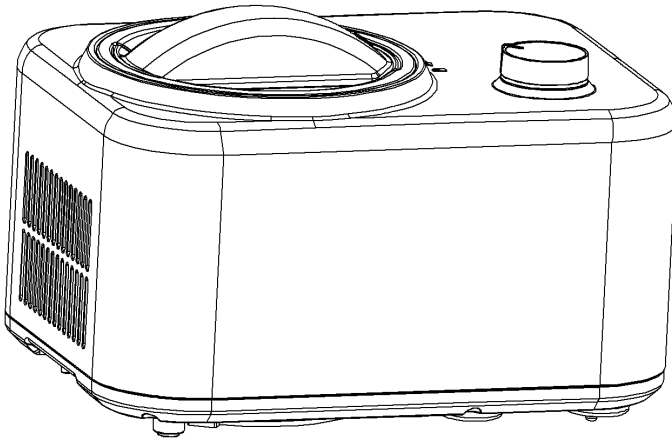

Item No: IC3908

Model No: ICE0830

Thank you for purchasing this product! If you have any questions about the product, such as missing parts, damaged products, product assembling, or operation, please contact us via Amazon Message or customer service number:

213-4467172 or 661-4358826.

IMPORTANT NOTICES

When using an electrical appliance, basic safety precautions should always be followed to reduce the risk of fire, electric shock, and/or injury, including the following:

1. Read all instructions before using.
2. Ensure the voltage is compliant with the voltage range stated on the rating label, and ensure the earthing of the socket is in good condition.
3. If the supply cord is damaged, it must be replaced by the manufacturer or its service agent or a similarly qualified person in order to avoid a hazard.
4. This appliance is not intended for use by persons (including children) with reduced physical, sensory or mental capabilities, or lack of experience and knowledge, unless they have been given supervision or instruction concerning use of the appliance by a person responsible for their safety. Children should be supervised to ensure that they do not play with the appliance. This appliance can be used by children over the age of 8 and persons with reduced physical, sensory or mental capabilities or lack of experience and knowledge if they have been given supervision or instruction concerning use of the appliance in a safe way and understand the hazards involved. Children shall not play with the appliance. Cleaning and user maintenance shall not be made by children without supervision.
5. This appliance is intended to be used in households and similar applications such as
 - staff kitchen areas in shops, offices and other working environments;
 - farm houses and by clients in hotels, motels and other residential type environments;
 - bed and breakfast type environments;
 - catering and similar non-retail applications.
6. –Warning: Do not use electrical appliances inside the food

storage compartments of the appliance, unless they are of the type recommended by the manufacturer.

–WARNING: When positioning the appliance, ensure the supply cord is not trapped or damaged.

–WARNING: Do not locate multiple portable socket-outlets or portable power supplies at the rear of the appliance.

7. The plug must be removed before cleaning, maintaining or filling the appliance.
8. Do not upend this product or incline it over a 45° angle.
9. To protect against risk of electric shock, do not pour water on cord, plug and ventilation, immerse the appliance in water or any other liquid.
10. Unplug the appliance after using or before cleaning.
11. Keep the appliance 8cm from other objects to ensure the good heat releasing.
12. Do not use the accessories which are not recommended by Manufacturer.
13. Do not use the appliance close to flames, hot plates or stoves.
14. Do not switch on the power button frequently (ensure 5min. interval at least) to avoid the damage of compressor.
15. Metal sheets or other electric objects are not allowed to be inserted into the appliance to avoid fire and short circuit.
16. When taking out the ice cream, do not knock the barrel or edge of barrel to protect the barrel from damage.
17. Do not switch on the power before install well the barrel or blender blade.
18. The initial temperature of the ingredients is $20\pm 3^{\circ}\text{C}$. Do not put the ingredients into freezer for pre-freeze, as it will easily make the blender blade blocked before the ice cream is in good condition.
19. Do not remove the blender blade when the appliance is on working.
20. When you turn the ice cream maker on without adding ice cream ingredients, you will slightly hear the mixing paddle scratching

the loading bowl, which is a normal phenomenon.

21. There are two round copper sheets at the motor assembly of the transparent cover installed on the upper cover. When using, please wipe the water stains on the transparent cover and on the copper plates. If the machine is in use, the two copper plates will be connected by water, which will lead to power failure of the motor. Pull out the power line, wipe the water stains, and restart it.
22. Do not use outdoors.
23. Never clean with scouring powders or hard implements.
24. Please keep the instruction manual.

SPECIFICATIONS

Item no: IC3908

Model no:ICE0830

Capacity: 0.8L

Voltage: 110-120VAC/60Hz

Anti-shock protection class: I

Climate type: N/SN

Power consumption: 100W

Max overall dimensions: 315 (W) X 235 (D) X 211 (H) mm

Max Packing Dimensions: 395 (L) X 313 (W&D) X 258 (H) mm

N.W: 6.3kg

G.W: 6.8kg

PRODUCT FEATURE

1. Knob-operated control, simple and reliable operation and won't cost you much trouble.
2. Plastic housing, elegant, fashionable and lighter.
3. Upper mixing and low noise.
4. With a variety of quick freezing ice cream production methods.
- 5 .The parts are detachable, easy to clean, sanitary and safe.

PRODUCT INSTRUCTION

1) Structure

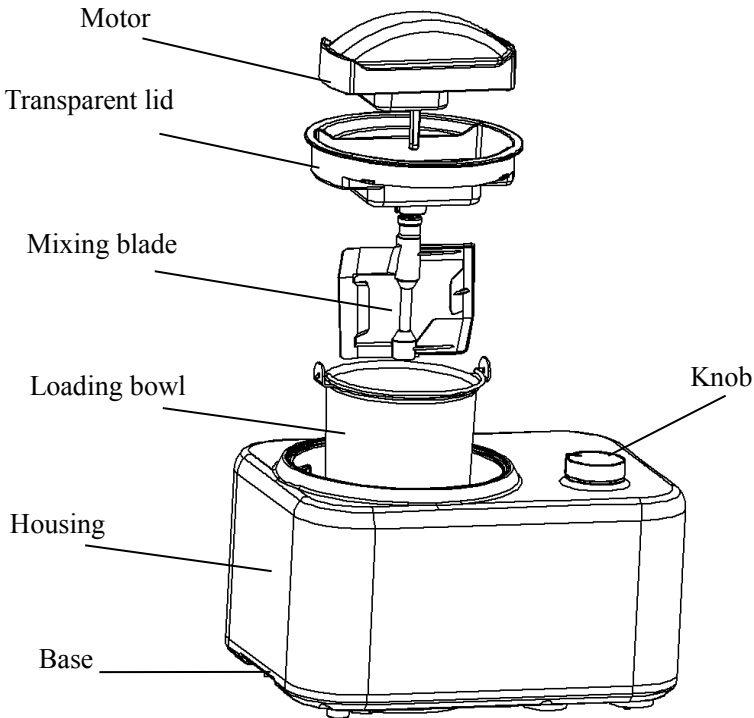

2) Control panel

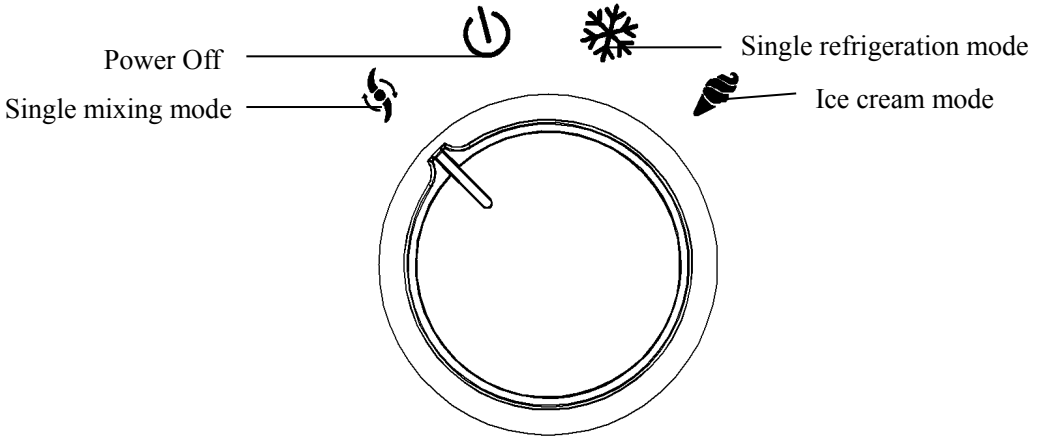

The product is subject to the actual object, and the picture is for reference only.

HOW TO MAKE ICE CREAM

NOTE: Please thoroughly clean all parts that will contact with ice cream before use, including: cooling bowl, loading bowl, mixing blade, transparent lid, etc.

Before cleaning, you must ensure that the power cord plug is disconnected from the outlet. When making ice cream, keep the machine flat on a level surface to ensure that the compressor of the machine is working properly.

Here are the steps to make an ice cream:

Step 1.

Pour the well prepared recipe ingredients in proportion into the

removable bowl, then mix it uniformly.

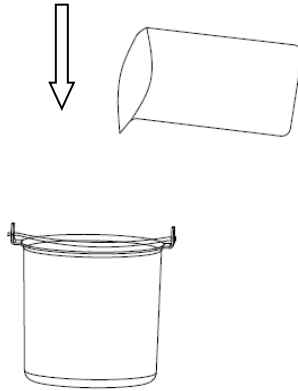

Step 2.

Then put the loading bowl into the ice cream machine, both ends of the loading bowl handle shall be aligned with the groove of the upper cover.

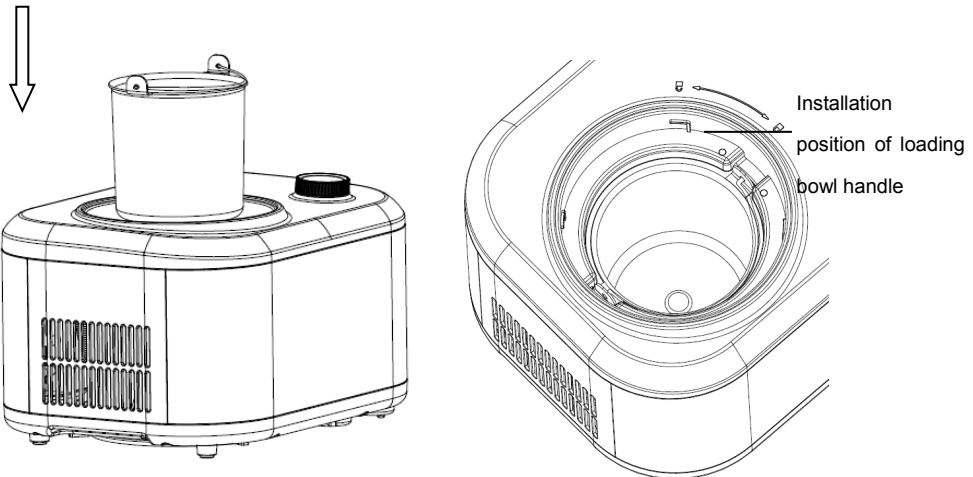

Step 3.

Install the transparent lid and motor assembly.

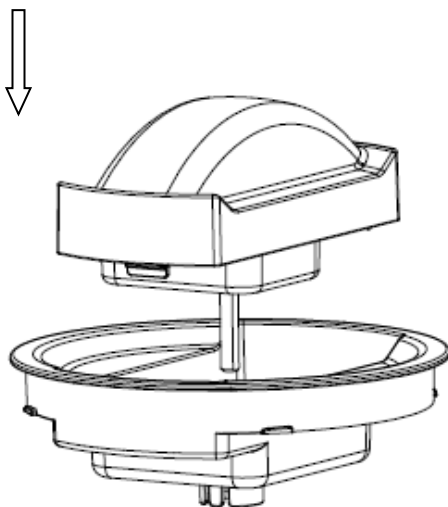

Step 4.

Install the mixing blade, transparent lid and motor assembly

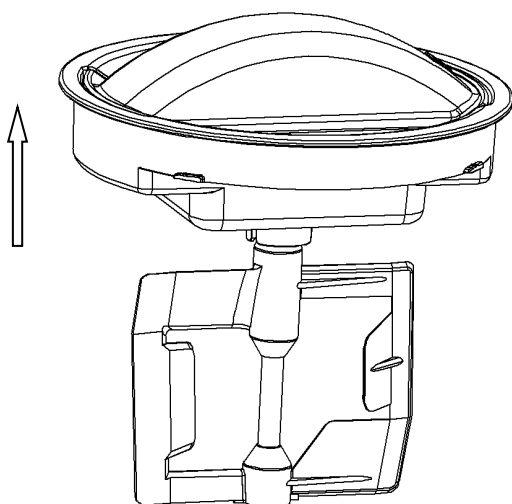

Step 5.

Put the components installed in step 4 into the ice cream machine, make sure that the center of the convex hull of the loading bowl and the motor components of the mixing fan blade are in the same straight line, lock the components clockwise, and make sure that the triangle mark on the components rotates to the "LOCK" mark

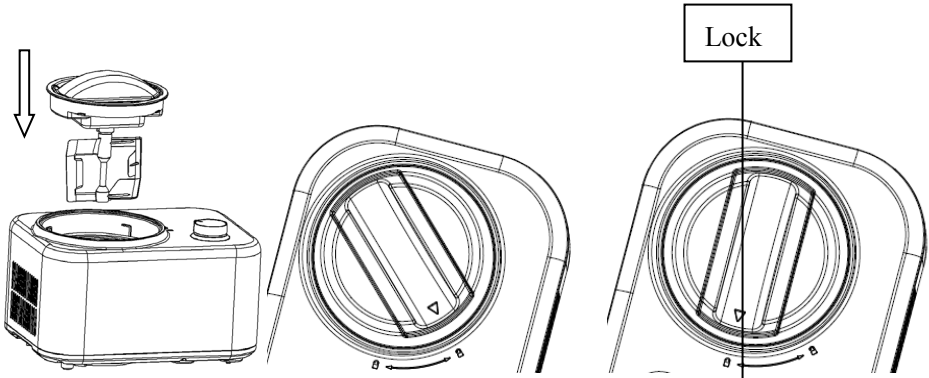

Step 6.

Plug in the power and turn the knob to select the ice cream mode

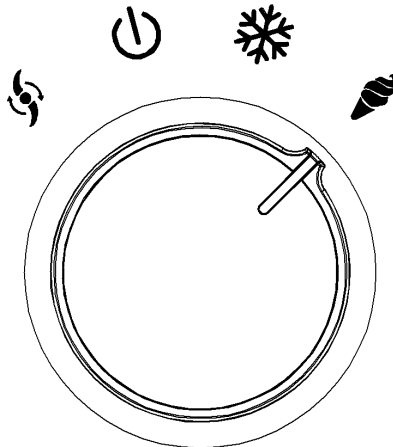

Step 7.

When the ice cream making is finished, turn the knob back to the “OFF” position

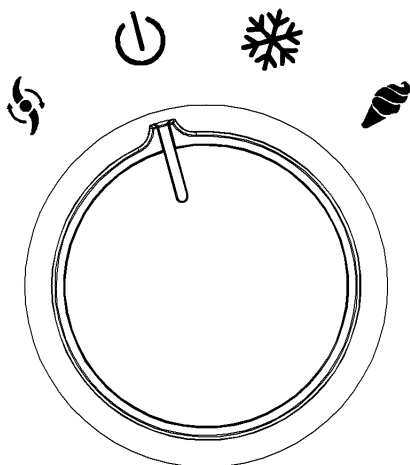

Step 8.

Turn the transparent lid and motor assembly anticlockwise. When the triangle mark is aligned with the unlocking mark, take out the assembly and then take out the loading bowl

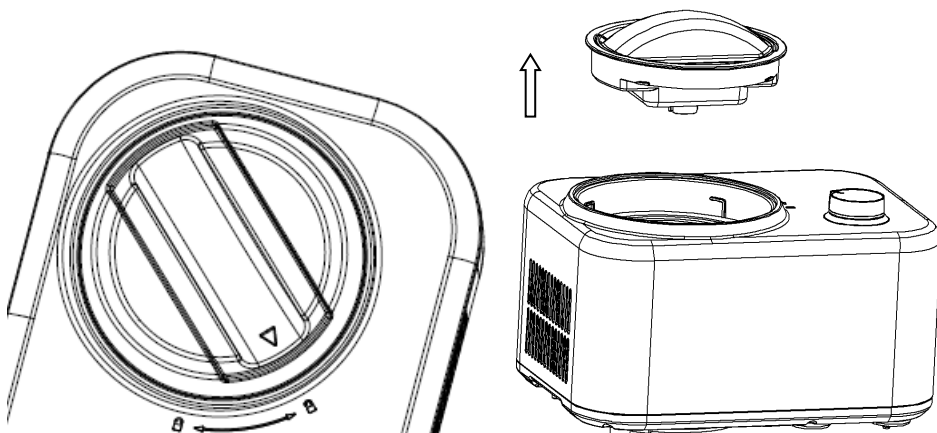

OPERATION

1. Connect the power supply and plug the power cord into a suitable socket. The shape and voltage of the socket shall be the same as those indicated.

2. KNOB CONTROL FUNCTIONS

1). Function description of buttons

①Single mixing mode:

Set the working time and turn the knob to the single mixing mode, and the mixing motor start the mixing function. When the time or hardness reaches the preset value, there will be 10 beeps to remind that the mixing is completed. After completion, please turn the knob to other positions before any other operations.

②Single refrigeration mode

Set the working time and turn the knob to the single refrigeration mode, the compressor and cooling fan are started to realize the refrigeration function. After completion, there will be 10 beeps to remind that the refrigeration is completed. After completion, please turn the knob to other positions to carry out other operations.

③Ice cream mode

Set the working time and turn the knob to the ice cream mode. The compressor, mixing motor and cooling fan start to make ice cream. When the time or hardness reaches the set value (indicating that the ice cream is completed), there will be 10 short beeps. At this time, you can enjoy the ice cream. If there is no other operation, it will enter the insulation function automatically, and 10 short beeps will appear after the insulation is completed.

3. KEEP COOL FUNCTION

Ice cream keep cool function: In order to prevent you from leaving during the ice-cream making process, and the ice-cream cannot

be eaten or stored in time after the completion of the production, which causes the ice-cream to melt, we have added the following humanized design: when the ice-cream making is completed but no one operates, the machine will start the refrigeration function at regular intervals, so as to keep the ice cream fresh taste and texture. The cooling time is 1 hour. There are 10 short beeps when it is finished, and then the machine will be shut down automatically. Please turn the knob back to the “Power OFF” position.

4. MOTOR SELF-PROTECTION FUNCTION

4.1 The motor has overcurrent protection function. For example, when the hardness of ice cream reaches the set value, it will stop automatically.

4.2 In the ice cream mode and single mixing mode, if the motor components are not installed in place, the buzzer will give an alarm every 30s and sound 10 times, which will last for 10 times. If the motor components are not installed in place after that, the machine will enter the standby state.

5. COMPRESSOR SELF-PROTECTION FUNCTION

After switching from ice cream mode or single refrigeration mode to shutdown mode, if it is switched back to ice cream mode or single refrigeration mode again, the compressor has a protection time of about 3 minutes. However, after unplugging the power line, start the machine again. The default is to restart. At this time, there is no delay when selecting ice cream mode or single refrigeration mode again.

6. CONTROLLING THE VOLUME OF THE INGREDIENTS

To avoid overflow and waste, please make sure that the ingredients do not exceed 60% of capacity of the removable bowl (Ice cream expands when being formed).

ELECTRICAL DIAGRAM

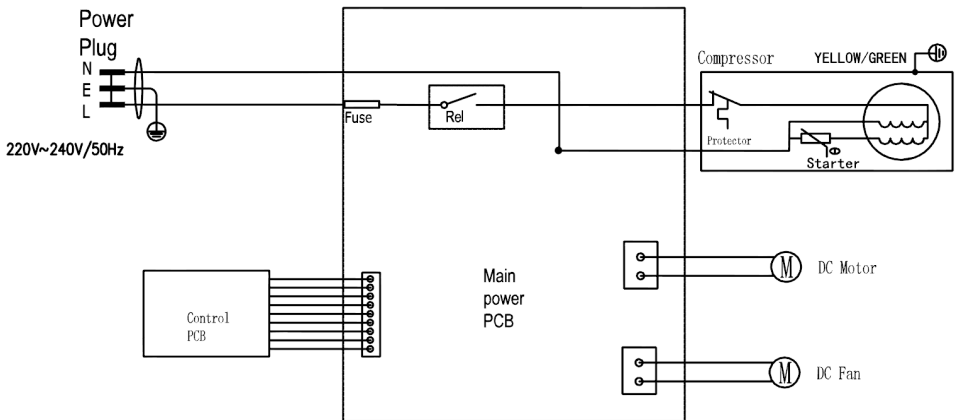

MAINTENANCE

Caution: The plug must be removed before cleaning to avoid electric shock.

- (1) Take out the mixing blade, wipe it with a dampened cloth
- (2) Take out the removable bowl, clean it with a dampened soft cloth
- (3) Wipe the transparent lid and refill lid with a dampened cloth
- (4) Remove the dirty on the body or other places with a dampened cloth, and do not pour water on cord, plug and ventilation, immerse the appliance in water or any other liquid
- (5) Allow drying thoroughly with a dry cloth, then return the component to the home position.

COMMON PROBLEM & SOLUTIONS

No.	Existing problems	Reason analysis	Resolutions
1	Can not take out the loading bowl easily after the ice cream is finished	There are water drops between the cooling bowl and the loading bowl that haven't been wiped away, resulting in freezing	Wait 3-8 minutes before taking out the loading bowl.
2	The transparent lid is lifted to the mixing blade, and it cannot be stuck in place	The mixing blade not in place, and pay attention to the alignment of the convex hull at the bottom	Put the mixing blade in place and rotate the transparent cover in place
3	The loading bowl cannot be placed in the cooling bowl	Deformation caused by improper use of loading bowl	Buy a new loading bowl
4	At the beginning of making ice cream, the mixing blade seriously scratched or jammed.	Deformation caused by improper use of loading bowl	Buy a new loading bowl

AFTER SALES SERVICE

One-year warranty service is available from the date of purchase. The date of purchase of the invoice or after-sales service warranty card is subject to the warranty service. The problems you encounter when using our company's home automatic ice cream machine can be helped and resolved through the service hotline. We provide technical advice free of charge.

- One of the following conditions is not covered by the warranty:
 - 1) Components are damaged due to improper use, maintenance and storage;
 - 2) Damage caused by non-Donlim WEILI maintenance personnel or designated personnel to disassemble the product by themselves.
 - 3) No purchase invoice or purchase invoice does not match the product;
 - 4) Damage caused by force majeure;
 - 5) Exceeding the warranty period.
- ★ If you find any quality problems, please contact the service center or special maintenance service point for repair. Do not disassemble it by yourself. The company will not bear any responsibility for quality problems or accidents caused by self-disassembly.
- ★ If the product is not under warranty, the maintenance fee will be waived and only the parts fee will be charged. Manufacturer reserves the right of final interpretation of the above commitments.

PARTS

Mixing blade	1	User manual	1
--------------	---	-------------	---

ICE CREAM RECIPE MANUAL

BASIC ICE CREAM

Make it according to the following formula. After mixing the formula mixture evenly, it can be made into ice cream within 60 minutes.

160g cream

96g powdered milk

144g water

VANILLA ICE CREAM

160g whole milk

76g granulated sugar

120g heavy cream, well-chilled

0.5 – 1.5 teaspoons pure vanilla extract, to taste

In a medium bowl, use a hand mixer or a whisk to combine the milk and granulated sugar until the sugar is dissolved, about 1 – 2 minutes on low speed. Stir in the heavy cream and vanilla to taste. Turn machine on, pour mixture into freezer bowl through ingredient spout and let mix until thickened, about 50 – 60 minutes.

BASIC CHOCOLATE ICE CREAM

160g whole milk

76g granulated sugar

160g bittersweet or semi-sweet chocolate (your choice), broken into 1.2cm pieces

160g heavy cream, well chilled

0.6 teaspoon pure vanilla extract

Heat the whole milk until it is just bubbling around the edges (this may be done on the stovetop or in a microwave). In a blender or food processor fitted with the metal blade, pulse to process the sugar with the chocolate until the chocolate is very finely chopped. Add the hot milk, process until well blended and smooth. Transfer to a medium bowl and let the chocolate mixture cool completely. Stir in the heavy cream and vanilla to taste. It is best to pre-cooled in the refrigerator for about 15 minutes before making.

Turn the machine on, pour the mixture into freezer bowl through ingredient spout and mix it until thickened, about 30 – 40 minutes.

FRESH STRAWBERRY ICE CREAM

167g fresh ripe strawberries, stemmed and sliced

35g freshly squeezed lemon juice

76g sugar, divided

160g whole milk

160g heavy cream

0.6 teaspoon pure vanilla extract

In a small bowl, combine the strawberries with the lemon juice and 76g of the sugar; stir gently and allow strawberries to macerate in the juices for 2 hours.

In a medium bowl, use a hand mixer or a whisk to combine the milk, and granulated sugar until the sugar is dissolved. Stir in the heavy cream plus any accumulated juices from the strawberries and vanilla. Turn the machine on, pour mixture into freezer bowl through ingredient spout and mix it until thickened, about 30 – 40 minutes. Add the sliced strawberries during the last 5 minutes of freezing.

FRESH LEMON SORBET

235g sugar

280g water

80g freshly squeezed lemon juice

0.5 tablespoon finely chopped lemon zest

Combine the sugar and water in a medium saucepan and bring it to a boil over medium-high heat. Reduce heat to low and simmer without stirring until the sugar dissolves, about 3 – 5 minutes. Cool it completely. This is called a simple syrup, and could be made ahead in larger quantities to have on hand for making fresh lemon sorbet. Keep it refrigerated until ready to use.

When cool, add the lemon juice and zest; stir to combine. Turn the machine on, pour the lemon mixture into freezer bowl through ingredient spout and mix until thickened, about 50 – 60 minutes.

CHOCOLATE FROZEN YOGURT

160g whole milk

180g bittersweet or semisweet chocolate, chopped

268g low-fat vanilla yogurt

33g sugar

Combine the milk and chocolate in a blender or food processor fitted with the metal blade and process it until well-blended and smooth, then Add the yogurt and sugar; process it until smooth, about 15 seconds. Wait for full cooling. Turn the machine on, pour the mixture into freezer bowl through ingredient spout and mix it until thickened, about 50-60 minutes.

Correct Disposal of this product	
	This marking indicates that this product should not be disposed with other household wastes throughout the EU. To prevent possible harm to the environment or human health from uncontrolled waste disposal of, recycle it responsibly to promote the sustainable reuse of material resources. To return your used device, please use the return and collection systems or contact the retailer where the product was purchased. They can take this product for environmentally safe recycling.

Thank you for purchasing this product! If you have any questions about the product, such as missing parts, damaged products, product assembling, and operation, please contact us via **Amazon Message** or customer service number: **213-4467172 or 661-4358826**

IMPORTANT

Please call our customer service department for any consulting:

213-4467172

661-4358826

(8:30am - 5:30pm P.S.T.)

DATED PROOF OF PURCHASE IS REQUIRED FOR WARRANTY SERVICE.

AVIS

Veillez appeler le service à la clientèle pour toutes questions au:

213-4467172

661-4358826

(8:30am - 5:30pm P.S.T.)

PREUVE D'ACHAT ORIGINALE REQUISE POUR SERVICE DE GARANTIE.

IMPORTANTE

Sólo hay que llamar nuestro departamento de servicio al cliente en caso de tener preguntas o inquietudes:

213-4467172

661-4358826

(8:30am - 5:30pm P.S.T.)

SE REQUIERE PRUEBA DE COMPRA CON FECHA PARA SERVICIO BAJO GARANTÍA.

Address: ROWAN ELECTRIC APPLIANCE LLC 28407

Ascent Way, Santa Clarita, CA 91350

Phone: 213-4467172 or 661-4358826