

Personal Liquid Heating Garment
Model: COMP-PLHG-12100
Rev: A

Operation Manual



Compcooler, keep your body cool and comfortable in harsh conditions.

COMPCOOLER Introduction:

Compcooler Technology specializes in working for personal cooling & heating systems for harsh conditions. Compcooler has established its resume as a manufacturer for Military, Electronic, Medical cooling equipment. The employees at Compcooler's state of the art manufacturing facility have been producing liquid heating & cooling systems over 15 years. Quality system: ISO9001 and AS9100 registered facility. Certifications for major items: CE, FCC, UL, PSE, CB, FDA.

Product Categories

1. ICE Water Circulation Systems
2. Micro Refrigeration Chiller Units
3. Liquid Heating Systems
4. Liquid Cooling & Heating Garment and Pad
5. Customized Cooling Systems
6. Industrial Chiller or Cooling Module

Certifications for major items



Quality System for facility



Compcooler, keep your body cool and comfortable in harsh conditions.

Personal Liquid Heating System

Model: COMP-PLHS-12100

Description:

COMP cooler Personal Liquid Heating System (PLHS) is an active heating unit to keep your body warming in outdoor cold environment and indoor without heating device. PLHS includes Liquid Heating Unit (LHU), Liquid Circulation Heating Garment and Rechargeable battery. Liquid heating unit delivers 100W heating capacity to warm the liquid, temperature setting 30°C-48°C (86°F-120°F), LHU pumps heated water to heating channel embedded on garment and continuously flow around the body, once the circulation liquid reaches to set point temperature, system intellectually control the heating capacity to that temperature. DC 12V battery or vehicle power operated. User may expect more comfortable full body warming from the liquid heating garment if compare with electric heating pad clothing.

Benefits:

Reduces the Risk of Hypothermia, Maintains Body Core Temperature
 Reduces the Cold stress and Cold injuries, protect Vital organs
 Thermal Comfort, Reduces Clothing layers, Free Body Movement
 Recover vital signs, Rescue the life in cold conditions
 Maintain cognitive skill, enhance operational effectiveness

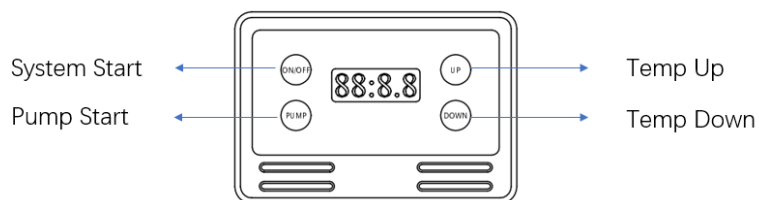
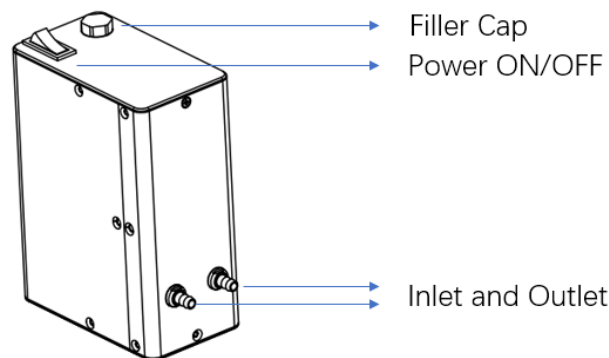

Compcooler, keep your body cool and comfortable in harsh conditions.

Components List:

Item	Part number	Description	Quantity
1	COMP-LHU-12100	Compact Liquid Heating Unit	1
		Handcarry Pack	1
2	COMP-ET1M	Extension Tubing 1 meter (3ft)	1
3	COMP-PCDC-12EC5	Power Cord with EC5 connector	1
4	COMP-LHV-XX	Black Liquid Heating Vest	1
5		Operation Manual	1

Optional Components

Item	Part number	Description	Quantity
1	COMP-RB1220	12V 20A 240W Rechargeable Battery with AC 110-220V charging	1
2	COMP-RB1210	12V 10A 120W Rechargeable Battery with 12V vehicle charging or AC 110-220V charging	1
3	COMP-PA-12280	Power Adapter AC110-220V to DC 12V, 280W	1
4	COMP-ET2M	Extension tubing 2meters 6ft	1

Heat Unit Dimension

158x116x67 mm

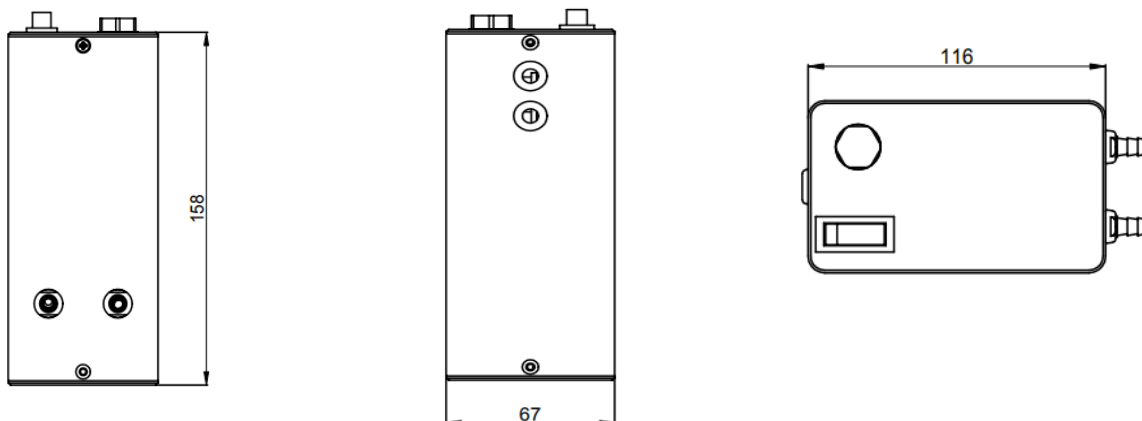

Compcooler, keep your body cool and comfortable in harsh conditions.

Technical Datasheet for Compact Liquid Heating Unit

Heating Capacity (Ambient Temp. 30°C)		W	120
Operation Voltage		V DC	11-16
Operation Current		A	10
Max Current		A	13
Max Power Consumption		W	150
Temp Control		°C	30 to 48
		°F	86 to 120
Accuracy		+/-°C	1
Reservoir		ml	200
Pump	Voltage	V DC	12
	Water flow	L/Min	1
	Lift	M	2
Circulation Liquid	Antifreeze	°C	-50
	Mixture		50%water and 50% Glycol
Power Connector	Type	DC	EC5
Operation Ambient		°C	-20 to 50
Storage Temp		°C	-30 to 70
Protection for Heating Unit	Low Voltage	≤11	Yes
	High Voltage	≥18	Yes
	Wrong Polarity connection		Yes
	Overheating for Heating rod	≥80°C	Yes
	Liquid Level		Yes
Noise	Max	dBA	38
Color			Red Black
Dimension	L x W x H	mm	158x116x67
		Inch	6.2x4.6x2.6
Weight		KGS	1.2
		LBS	2.6

Compcooler, keep your body cool and comfortable in harsh conditions.

Voltage and Heating Capacity Curves

Operation voltage range is from 11V to 16V DC.

Heating capacity may be increased if voltage more than 12V, unit will be protected if voltage more than 18V, user need to restart the unit once voltage back to 12V-16V.

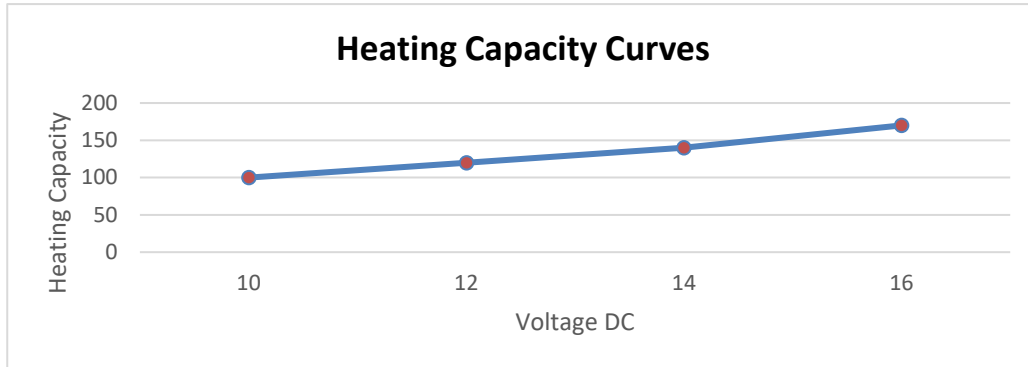

Temp Setting and Power Consumption Curves

Temp setting range is from 30-48°C (86-120°F)

High temp setting means longer heating time and more power consumption.

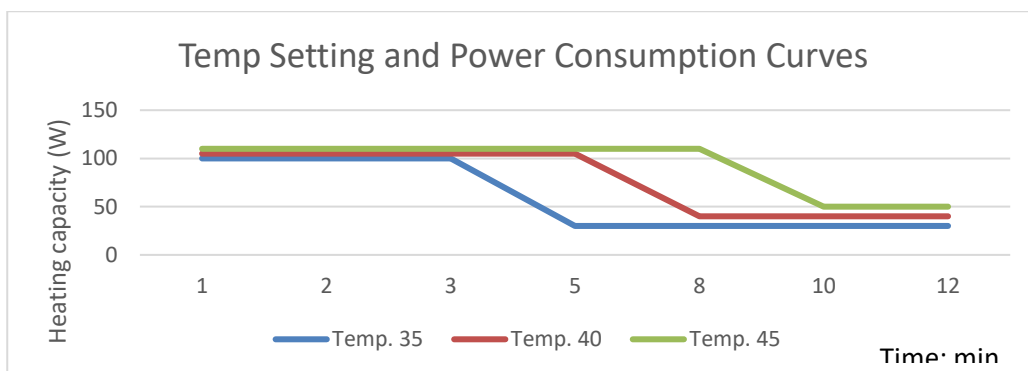

Temp Setting and Operation current Curves

Heating unit will intellectually control the heating capacity to setting temperature. Power consumption or operation current may be changed for different ambient.

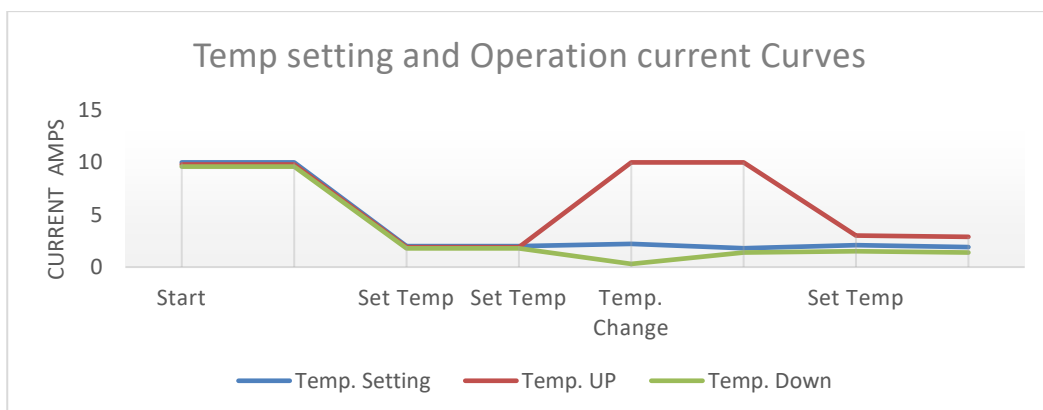

Compcooler, keep your body cool and comfortable in harsh conditions.

Specification

Liquid Circulation Heating Garment

Fabric Material: Modal Cotton wrinkle free Scuba
 85% Poly 15%Spandex
 Liner: Soft Mesh
 Tubing Material: Silicon
 Zipper: YKK
 Connector: Quick Fitting
 Weight:1kg
 Size: XS/S, M/L, XL/XXL, XXXL/XXXXL

Specification

Rechargeable Battery and Charger

Battery: Li-Ion Rechargeable Battery
 COMP-RB1220
 Operation Voltage: 11-16.8V
 Power: 240W
 Output connection: EC5
 Max Output Current: 30A
 Charging: 110/220V AC charging
 Weight: 3.3lbs
 Size: 6.2x3.4x2.7"

System Operation

Intelligent Temperature Control from 30-48°C
 Accuracy: +/-1°C
 Battery Heating time: 120-400 minutes based on Temp setting
 Antifreeze Liquid: water with glycol (50% and 50%)

Garment Size:

Item	XS/S	M/L	XL/XXL	3XL/4XL
Chest	84	100	108	126
Waist	76	92	100	118
Length	64	68	70	73
Sleeve Length	58	59	60	61
Collar Length	46	48	50	52
Collar Height	4.5	4.5	4.5	4.5

Compcooler, keep your body cool and comfortable in harsh conditions.

Operation processes

Preparation

Power connection:

Battery: connect liquid heating unit with battery by EC5 connector (Blue)

Power Adapter: connect liquid heating unit with power adapter by EC5 connector (blue)



Heating Vest Connection:

Connect heating unit with vest by quick release fittings, once you hear a click, it's in position.
 (No inlet or outlet from vest connectors)

Temp Setting:

Press Up and Down to set up temperature from 30 to 48°C

Overheating Testing:

User may start overheating protection testing before fill circulation liquid.

Turn on ON/OFF, heat unit will start to work, front panel will show E4 in 10-30seconds. It means protection works fine.

Turn off the power switch, then restart the heating unit, it will back to work.

Circulation Liquid

User needs to fill circulation liquid by twice.

The first time, remove the filler cap from top side, add liquid to full by funnel, connect liquid heating garment, turn on the pump, unit circulates the liquid from reservoir to heating garment.

The second time, keep running and allow the liquid heating garment fill with water for 30-60 seconds (without heating), refill again to full (maybe couple times, be patient), then tight the filler cap.

Clean or distilled water is fine if ambient more than 1°C

Deionized water for isolation request.

Anti-freeze liquid for ambient below 0°C.

DO NOT use salt water, caustic, corrosive flammable fluids!



or

Compcooler, keep your body cool and comfortable in harsh conditions.

Battery Charging:

Full charge of battery, LED light on charger changed from Red to Green.

Press the button “ Remaining Battery Capacity” on battery, 3 lights 80%-100%, 2 lights 50%-80%, 1 light 40% less.

Pre-heating testing:

User may turn on the system and start heating, no pump circulation, temperature will be increased in minutes.

Leak checking

User may check if any leak from heating garment or extension tubing or liquid heating unit.

Operation

Operation Processes:

1. Put on liquid heating garment, connect the extension tubing with liquid heating unit.
Once you hear a click, it's in position.
2. Power connection: connect the battery or vehicle DC12V power, turn on power switch and light the front panel.
The heating unit will be in standby mode.
3. Start heating: user may press ON/OFF to start heating, liquid temp will go up to set point in minutes.
Pump will start to work once temp get to set point.
4. Temp setting: user may press up and down to set up the temp for circulation liquid as need.
If you are unsure the temp to begin, start at 35°C (96°F) and adjust up or down from there.
5. Start circulation: Pump will start to work by auto once liquid temp get to set point.
User may press the pump to start or stop circulation. Please make sure the tubing is connected (no kinks) before circulation.

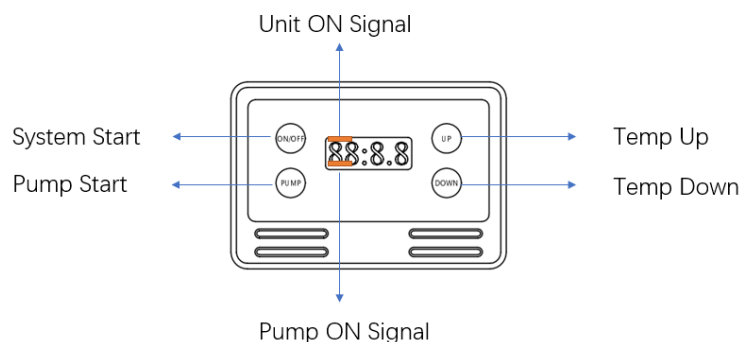

Extend Heating Time: it is a quick way to extend heating time by replace full charged battery.

Compcooler, keep your body cool and comfortable in harsh conditions.

Clean and Maintenance

Liquid Heating Unit:

Unplugged the vehicle power or battery, use a clean damp cloth to clean the outside of heating unit.

Use compressed air to remove dust and debris.

Reservoir cleaning

Please disconnect the extension tubing from heating unit, then remove the remain water from filler cap and open for dry.

Liquid Heating Garment:

Prefer to clean by hand wash then hang dry.

Machine wash with laundry bag, using a front-loading wash machine with cold water on a gentle/delicate cycle, laundry bag to minimize risk of damaging connector and tubing sewing.

Note: DO NOT BLEACH, NO IRON, NO DRYER, TUMBLE DRY ON LOW

Heating Unit Storage:

1. Turn off heating unit, disconnect the power cord.
2. Disconnect the extension tubing.
3. Empty the circulation water and open dry.
4. Pack the unit for storage.

Restart: after long term storage, please fill in clean water with less degerming agent, run system over 10 minutes with heating vest connection. Then empty the system and re-fill in the liquid as need.

Battery Storage

1. Shall be in the clean and dry ventilation room at temperature 0°C-35°C (32°F-95°F)
2. Shall keep out of fire or heat and avoid touching corrosion elements
3. Shall be charged every 6 months during storage
4. Keep the battery out of children's reach

Please STOP using the battery if any abnormal be found!

Trouble shoot and Fault Code

Item	Code	Description
1	E1	Wrong Polarity or reverse connection from power input
2	E2	Low voltage protection, less than 10V
3	E3	High voltage protection, more than 18V
4	E4	Overheating protection for heating rod, over 80°C if lack water
5	E5	High temp protection for circulation liquid, 10°C higher than setting
6	P1	No liquid temp signal from sensor
7	P2	No temp signal from overheating protection device

Compcooler, keep your body cool and comfortable in harsh conditions.

Cautions:

1. Please check vehicle voltage is 12-16V DC before connection.
2. Please make sure vehicle power output more than 15A or 200W for DC operation.
3. Please make sure Heating garments or vest be connected before start pump circulation, it may cause unit leak because of pump pressure.
4. Please use anti-freeze liquid if ambient lower than 0°C
5. Please do not run the system close to fire or under water.
6. Please stop operation and disconnect the power if more steam from filler cap.

Safety:

It is important to become thoroughly familiar with the manual and operating characteristics of the unit. It is the owner's responsibility to assure proper operator training, installation, operation and maintenance of the unit. Observe all warning can result in injury to the operator and severe mechanical damage to the unit.

Warranty:

Compcooler Warrants to the original Purchaser that products sold shall be free from defects material and workmanship for warranty period not exceed one year from the date of shipment. Compcooler agrees to correct for the original user of this product, either by repair, or at the manufacturer's election by replacement. This warranty shall not apply if the defect or malfunction was caused by accident, neglect, unreasonable use, improper service, or other causes not arising out of defects in material or workmanship. The manufacturer's sole obligation under this warranty is limited to the repair or replacement of a defective product and shall not in any event be liable for any incidental or consequential damages of any kind resulting from use or possession of this product.

Compcooler, keep your body cool and comfortable in harsh conditions.