

**MODEL: A323**  
**INSTRUCTION MANUAL**

V1.3

# TABLE OF CONTENT

1. IN THE BOX.....	1
2. IMPORTANT NOTE.....	1
3. INTRODUCTION.....	1
3.1. ABOUT THE CAMERA.....	1
3.2. APPLICATIONS.....	3
4. PARTS AND CONTROLS.....	3
5. INSTALLING THE BATTERIES AND SD CARD.....	6
5.1. LOADING BATTERIES.....	6
5.2. INSERTING THE SD CARD.....	7
6. USING THE CAMERA.....	8
7. THE OFF, ON, AND SET MODES.....	8
7.1. OFF MODE.....	9
7.2. ON MODE.....	9
7.3. SET MODE.....	9
8. ADVANCED SETTINGS.....	11
9. MOUNTING AND POSITIONING THE CAMERA... 15	
9.1. MOUNTING.....	15
9.2. SENSING ANGLE AND DISTANCE TEST.....	16
9.3. SWITCHING ON THE CAMERA.....	17
10. REVIEW PHOTOS OR VIDEOS.....	18
11. TECHNICAL SPECIFICATIONS.....	19
12. WARRANTY.....	21
13. FCC COMPLIANCE STATEMENT.....	22

## **1. IN THE BOX**

1 x Camera, 1 x Mounting Strap,  
1 x Instruction Manual, 1 x Mini USB Cord

*Note: Memory card and batteries are not included (user supplied).*

## **2. IMPORTANT NOTE**

Require eight (8) 1.5V AA Alkaline or Lithium batteries. We recommend the use of Energizer AA Lithium batteries in this camera to obtain maximum battery life.

Do not mix old and new batteries.

Do not mix battery type.

Rechargeable AA batteries are NOT recommended as the lower voltage they produce can cause operational issues.

Remove batteries when the camera is NOT in use.

Require a regular SD memory card (max capacity 128GB, Class 10). We recommend using SanDisk 32GB SDHC/Class10 memory cards in the camera to obtain the best cost-performance.

Before use, please remove the protective films on the front of the camera to get the best performance.

## **3. INTRODUCTION**

### ***3.1. ABOUT THE CAMERA***

The A323 trail camera is a new generation of digital scouting camera, it can be triggered by any movement of game in a location, detected by a highly sensitive Passive Infra-Red (PIR) motion sensor, and then take high quality pictures (up to 20MP

still photos), or 1080P 30fps H.264 video clips with audio.

The Camera features the all new innovative and ultra-clear Sony imaging technology. The camera encompasses all-new software innovations, smart illumination technology, blur reduction technology, auto noise reduction and dynamic exposure technology to deliver high resolution image quality, multi-zone detection, pre-activated technology and fast boot to deliver 0.1s fast trigger speed and 0.5s recovery time. The camera consumes very little power (less than 0.1mA) in a stand-by (surveillance) state. It can deliver 8 months standby operation time when the device is powered by eight AA 1.5V batteries.

### **Main features:**

- High quality pictures (up to 20MP still photos) or full HD video clips with audio. The camera is equipped with a Sony Starlight sensor, premium F1.6 great aperture lens and has exclusive imaging optimization algorithm, takes clear photos or videos even at low light or darkness environment.
- Clear night vision, flash range 100ft. The camera is equipped with 36pcs high performance infrared no glow 940nm LEDs that function as a flash (invisible to human eyes).
- Easy to use/program with well-designed operation buttons and built-in 2.31-inch LCD color screen, easy to review pictures and videos on the screen.
- Two working modes – Motion detection and Time lapse.
- Fast trigger time approx. 0.1~0.6 second (pre-activated technology with 3 PIR sensors designed), Fast recovery time less than 0.5 second, Long trigger distance up to 82ft.
- Info strip on each capture: Date, Time, Temperature & Moon Phase.
- Operation hours, Loop Recording, Time Lapse, Password protected.
- Built for any climate - IP66 Waterproof designed for outdoor

use and resistant against rain and snow. Operation Temperature -4~140°F.

- Support SD/SDHC/SDXC memory card, max capacity 128GB (*user supplied*).
- Extremely long in-field battery life up to 8 months in a stand-by state with 8 AA 1.5V batteries (*user supplied*).

### **3.2. APPLICATIONS**

The camera can be used as follows:

- For hunting, trail animals' trace or habit
- For wildlife observing and researching, captures pictures and videos of wild animals
- As sports camera, for riding, driving, camping or exploring
- As motion-triggered security camera, for home, farm, office and community
- All other indoor & outdoor surveillance where invasion evidence needed

## **4. PARTS AND CONTROLS**

The camera is equipped with 36pcs built-in high efficiency infrared LEDs, LED Indicators, Lens, PIR Sensors, Lock Holes in front view (*Figure 1*).

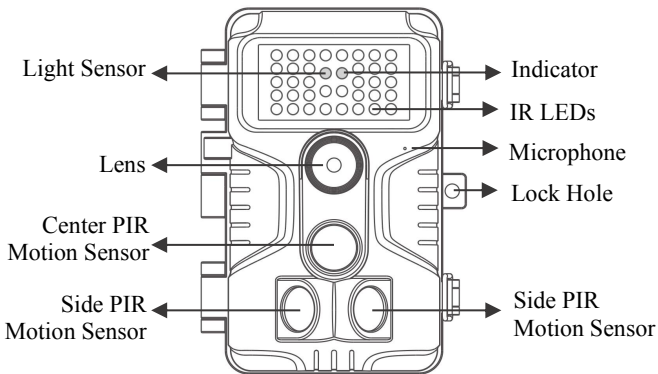

Figure 1: Front View

The camera provides the following connections for external devices: Mini USB port and SD card slot etc. (Figure 2).

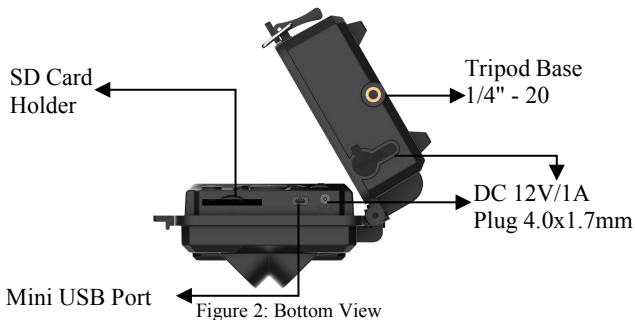

Figure 2: Bottom View

The camera has two strap holes on the back. The strap can be put through the strap holes and fastened securely around the tree trunk by pulling the end of the strap firmly (Figure 3).

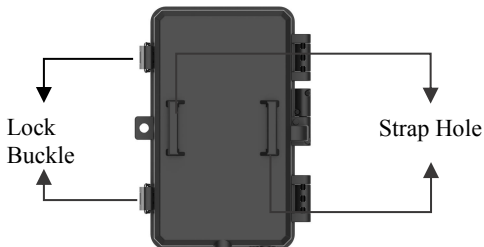

Figure 3: Back View

The camera has a 2.31-inch built-in LCD screen, which can be used for reviewing pictures or videos and menu displaying, and unique keypad design for easy program and operation, 8 AA batteries slot supported (*Figure 4*).



Figure 4: Inside View

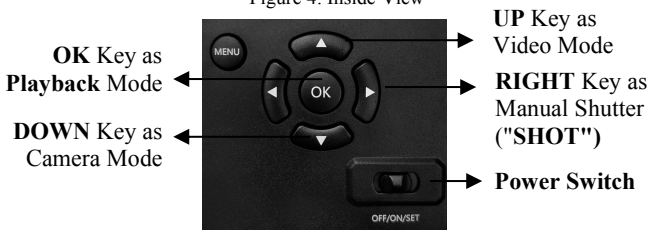

Figure 5: Operation Buttons and Shortcut

A 3-way power switch is used to select the main operating

modes: **OFF**, **ON**, and **SET** (*Figure 5*).

A control key interface with six keys is primarily used in **SET** mode to select operational functions and parameters. As shown in *Figure.5*, the keys can also perform a second function (shortcut operations in SET mode) in addition to their main function.

## **5. INSTALLING THE BATTERIES AND SD CARD**

Before you begin learning how to use your camera, you will first need to install a set of batteries and insert an SD card. Although that may only take you a minute, there are some important notes about both batteries and SD cards you should be aware of, so please take the time to **read the following directions and cautions**:

### **5.1. LOADING BATTERIES**

After opening the cover of the battery compartment, you will see that the camera has eight battery slots (*Figure 6*). A full eight batteries must be installed for the camera to operate. Be sure to insert each battery with correct polarity (negative or "flat" end against the long spring of each battery slot).

The camera takes 1.5V AA Lithium or Alkaline batteries. We recommend using 1.5V Lithium AA batteries (Energizer brand) to get maximum batteries lifetime. NiMH Rechargeable can also be used, but they might have a shorter life span due to their reduced efficiency over time and at low temperature, and would not work for night video recording.

On **SET** mode when battery power level gets low, the message "**Low Battery**" will show on the screen, please replace the batteries.



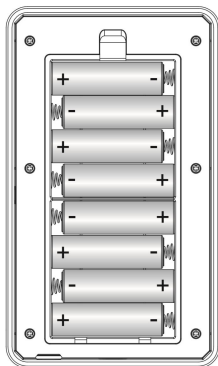

Figure 6: Loading the Batteries

## 5.2. INSERTING THE SD CARD

Insert the SD card (with the camera's power switch in the **OFF** position) before beginning to operate the camera. Don't insert or remove the SD card when the power switch is in the **ON** or **SET** position. The camera uses a regular memory card to save photos (in .jpg format) and/or videos (in .mp4 format). SD and SDHC (High Capacity)/SDXC cards up to a maximum 128GB capacity are supported (*Figure 7*).



Figure 7: Inserting the SD Card

The following describes how to insert and remove the SD card:

- Insert the SD card into the card slot with its label side

upwards. A "click" sound indicates that the card is installed successfully. If the wrong side of the card is facing up, you will not be able to insert it without force, there is only one correct way to insert cards. If the SD card is not installed correctly, the device will not display an SD card icon on the screen in SET mode. **Formatting the SD card** by using the camera's "Format" parameter in the menu settings before using it for the first time is recommended, especially when a card has been used in other devices.

- To take out the SD card, just gently push in the card (do not try to pull it out without pushing in first). The card is released from the slot and ready to be removed when you hear the click. Be sure the camera's power is switched **OFF** before inserting or removing SD cards or batteries.

## 6. USING THE CAMERA

Once you've prepared your camera by properly installing batteries and an SD card, you could simply take it outside, strap it to a tree (or not-according to your application scenario), switch it **ON** and leave-and you might get some great photos that are exactly what you wanted. However, we highly recommend that you first spend some additional time indoors with this manual and your camera until you know a bit more about what the 3-way switch and those control keys do. If nothing else, you'll probably want to at least set the date and time so the camera will imprint them (or not-it's your option) on your photos as they are taken, learn how to set the camera to shoot video clips instead of still photos if you like, and read some tips about mounting it on a tree.

## 7. THE OFF, ON, AND SET MODES

The camera has three basic operational modes:

- **OFF** mode: Power switch in the **OFF** position.

- **ON** mode: Power switch in the **ON** position.
- **SET** mode: Power switch in the **SET** position (screen is on).

### **7.1. OFF MODE**

The **OFF** mode is the "safe" mode when any actions must be taken, e.g., replacing the SD card or batteries, or transporting the device. And of course, when you are storing or not using the camera, you will switch it to **OFF**. Please note that in the **OFF** mode the camera consumes little power. It's a good idea to take the batteries out of the battery compartment if the camera will not be used for a long time.

### **7.2. ON MODE**

Anytime after the batteries and SD card have been inserted, you can switch on the camera. When the power switch is moved to the middle position, the camera will enter into the **ON** (Surveillance) mode. If the Mode is set as "Motion Detection", the camera will countdown 30-second delay and then be ready to capture images. If the Mode is set as "Time Lapse", there will be no 30-second counting down, and the camera will be ready to enter Time Lapse.

Once in the **ON** mode, no manual controls are needed or possible (the control keys have no effect). The camera will take photos or videos automatically (according to its current parameter settings).

You can either move the power switch directly from **OFF** to **ON** mode, or stop at the **SET** position first to change one or more settings, then move the switch to **ON** after you have finished doing so.

### **7.3. SET MODE**

In the **SET** mode you can check and change the settings of the camera with the help of its built-in screen. These settings, found

in the menu by pressing **MENU** key, let you change the photo or video resolution, interval between photos, switch the time imprint on, etc. (See more in Section 8 *ADVANCED SETTINGS*).

Moving the power switch to the **SET** position will turn on the screen display, and you will see an information screen that shows how many images have been taken, the battery level, camera or video mode, etc.

*Attention please: In **SET** mode, the camera will automatically enter **ON** mode if there is no operation (key pressing) within 5 minutes. Then the camera will perform as your settings in the menu.*

In the **SET** mode, you can connect the camera to a computer's USB port to download your images.

### ***Shortcut Keys/Functions***

As mentioned earlier in "Parts & Controls", the keypads have secondary, "shortcut" functions when the camera is switched to **SET** mode:

- Press the **UP** key to quickly set the camera to shoot video clips.
- Press the **DOWN** key to quickly set the camera to take still photos.
- Press the **RIGHT** key to manually trigger the shutter. This is useful for testing the camera. The "number of images taken" counter on the top right of the screen will increase by one.
- Press the **OK** key to playback. Then press **UP** or **DOWN** key to navigate the history photo or video if you want. Finally press the **OK** key to exit playback.

## 8. ADVANCED SETTINGS

The trail camera comes with preset manufacturer settings. You can change the settings to meet your requirements. Please make sure that the camera is in the **SET** mode. Once the camera screen is on, press **MENU** key to enter/exit the menu. Press the **UP/DOWN** key to move the marker, Press the **LEFT/RIGHT** key to change the setting, and press the **OK** key to confirm the change. Always remember to press the **OK** to save the change. Otherwise you will lose your new setting.

<b>Parameter</b>	<b>Settings (Bold = default)</b>	<b>Description</b>
<b>Mode</b>	<b>Motion Detection,</b> Time Lapse	In <b>Motion Detection</b> mode, the camera would take photos or videos once triggered. In <b>Time Lapse</b> mode, the camera would take photos or videos periodically according to your preset “Timelapse Interval” parameter.
<b>Photo or Video</b>	<b>Photo Video</b> Photo+Video	Select whether still photos or video clips are taken.
<b>Photo Quality</b>	20MP 16MP 8MP <b>4MP</b> 2MP	Select desired resolution for still photos from 2 to 20 megapixels. Higher resolution produces better quality photos, but creates larger files that take more of the SD card capacity. Larger files require longer time to write to the SD card, which will slightly slow the shutter speed.
<b>Photo Burst</b>	<b>01,</b> 02, 03, 04, 05	Select the number of photos taken in sequence per trigger in Camera mode.
<b>Video Quality</b>	<b>1080P</b> 720P	Select video resolution (pixels per frame). Higher resolution produces better quality videos, but creates larger files that take

		more of the SD card capacity.
<b>Video Length</b>	<b>10 seconds,</b> Optional from 3s to 5m	Videos are in MP4 format that can be played back on most video players. <i>Note: Night videos are limited to a maximum of 30 seconds to conserve the batteries. If set video length higher than 30 seconds, e.g. 60 seconds, the max recording length at night keeps 30 seconds.</i>
<b>Video Sound</b>	<b>On</b> Off	Selecting <b>On</b> will record video with sound.
<b>Video Format</b>	<b>MP4</b> MOV	MP4 is the mainstream format in the video industry, more compatible with any player. Select MOV in case some legacy digital camera software must be working with videos in MOV format.
<b>Frame Rate</b>	<b>30fps</b> 25fps	When the around light works at 50HZ and video flickering occurs, please select 25fps.
<b>Detection Delay</b>	<b>10 seconds,</b> optional from 0s to 60m	Select the shortest length of time that the camera will wait until it responds to any subsequent triggers from the PIR sensor after a game is first detected. During the selected interval, the camera will not take pictures/videos. This prevents the SD card from filling up with too many redundant images. <i>Note: this option is invalid if <b>Mode</b> is set as "Time Lapse".</i>
<b>PIR Sensitivity</b>	<b>High</b> Medium Low	Select the sensitivity of the PIR sensor. Temperature affects the sensitivity. The High setting is suitable when the ambient temperature is warm or you want to capture distant object or capture more, and

		<p>the Medium/Low setting is helpful in cold weather.</p> <p><i>Note: this option is invalid if <b>Mode</b> is set as “Time Lapse”.</i></p>
<b>Side Motion Sensors</b>	<b>On Off</b>	<p>Selecting <b>On</b> will activate the side motion sensors. It brings faster trigger speeds and helps capture fast moving animals. When any of the two side motion sensors detects a motion event, the camera will be pre-activated. If the animal enters the detection area of the center motion sensor within 5 seconds, the camera will start taking photos or videos according to the settings, otherwise the camera will re-enter standby mode again.</p>
<b>Motion Test</b>		<p>This feature helps you aim the camera at your target area. Please refer to the details in Section 9.2.</p>
<b>Timelapse Interval</b>	<b>1 hour,</b> optional from 1s to 24h	<p>Setting time lapse interval. It takes effect <b>ONLY</b> when <b>Mode</b> is set as Time Lapse, the camera will automatically take photos/videos according to the set interval, regardless of whether the PIR sensor has detected any game. This is helpful when observing cold-blooded animals like snakes, or the process of flowering, etc. <i>Note: This option is invalid if <b>Mode</b> is set as “Motion Detection”.</i></p>
<b>Date/Time</b>	M/D/Y hh:mm	<p>M – Month D – Day Y – Year hh – Hour mm – Minute</p>

		<p><i>Note: Use "LEFT/RIGHT" key to switch settings, use "UP/DOWN" to set current date and time.</i></p> <p><i>Date input format may change. Please refer to "<b>Date Format</b>" parameter settings accordingly.</i></p>
<b>Date Format</b>	D/M/Y M/D/Y Y/M/D	Select date format which will be shown on the screen and each capture.
<b>Time Format</b>	<b>12h</b> 24h	Select time format which will be shown on the screen and each capture. 12h - AM/PM
<b>Camera Name</b>	<b>On</b> <b>Off</b>	Select <b>On</b> to assign a 4-character long in the form of Capital A-Z, 0-9 to record the location in the photos (e.g. A123 for Yellow Stone Park). This helps multi-camera users identify the location when reviewing the photos.
<b>Info Strip</b>	<b>On</b> Off	Select <b>On</b> to show date, time, temperature, moon phase on each capture.
<b>Loop Recording</b>	<b>On</b> <b>Off</b>	Selecting <b>On</b> option will cause the oldest files to be overwritten with new captures when the SD card reaches its capacity. With <b>Off</b> option selected, the camera will erase image capture once the SD card reaches capacity.
<b>Operation Hours</b>	<b>On</b> <b>Off</b>	Select <b>On</b> if you only want the camera to work within a specified time period every day. For instance, if the starting time is set at 18:35 and the ending time at 8:25, the camera will function from 18:35 the current day to 8:25 the next day. Outside the time period the camera will not be triggered or take photos/videos.



<b>Password</b>	On Off	Set up a 4-digit password to protect your camera from unauthorized users. If the code is lost, you can contact customer support to reset the password.
<b>Format SD Card</b>	Yes No	All files will be deleted after formatting the SD card. Highly recommend you format the SD card if it has been used previously in other devices. <b>Caution: make sure wanted files on the SD card have been backed up first!</b>
<b>Factory Reset</b>	Yes No	Selecting <b>Yes</b> will return all your previous settings back to the manufacturer default.
<b>Version</b>	Defined	Display the version of the camera.

## 9. MOUNTING AND POSITIONING THE CAMERA

### 9.1. MOUNTING

After you've set up the camera's parameters to your personal preferences at home, you're ready to take it outside and slide the power switch to "ON". When setting up the camera for scouting game or other outdoor applications, you must be sure to mount it in place correctly and securely. We recommend mounting the camera on a sturdy tree with a diameter of about 6 in. (15cm). To get the optimal picture quality, the tree should be about 16-17 ft. (5 meters) away from the place to be monitored, with the camera placed at a height of 2.5-3.5 ft. (0.75-1m). Also, keep in mind that you will get the best results at night when the subject is within the ideal flash range, no farther than 65' (20m) and no closer than 10' (3m) from the camera.

There are two ways to mount the camera: using the provided adjustable web belt, or the tripod socket.

**Using the adjustable strap:** illustrates using the strap on the camera. Push one end of the strap through the two brackets on

the back of the camera. Thread the end of the strap through the buckle. Fasten the strap securely around the tree trunk by pulling the end of the strap firmly so there is no slack left (*Figure 8*). *Note: it is not possible to use a cable lock (in the upper part of the bracket) and the strap at the same time.*

**Using the tripod socket:** The camera is equipped with a socket at the bottom end to enable mounting on a tripod or other mounting accessories with a standard *UNC 1/4-20* thread screw (*user supplied*).



*Figure 8: Mounting the Camera*

## **9.2. SENSING ANGLE AND DISTANCE TEST**

To test whether the camera can effectively monitor the area you choose, this test is recommended to check the sensing angle and monitoring distance of the camera. To perform the test:

- Switch the camera to the **SET** mode.
- Select “Motion Test” in the Menu. The camera will countdown a max 30-second delay and be ready to capture motions. (*Note: The delay time may be less than 30 seconds, depending on the actual time of the motion sensor to be activated. The delay time is 30 seconds minus the power-on time.*)
- Close the camera door.
- Make movements in front of the camera at several positions within the area where you expect the game or subjects to be.

Try different distances and angles from the camera.

- If the motion indicator LED light (RED light) blinks, it indicates that position can be sensed. If it does not blink, that position is outside of the sensing area. *(Note: The red light will blink only when the motion is within the sensing area of the central PIR sensor. The central sensor's sensing angle of view is 60°. Each of the side sensors has a 30° angle of view, which is only used to pre-activate the camera and accelerate the triggering speed, there is no RED indicator blinking whatever each of the side sensors detects motions.)*
- In these sensing test, the camera would take pictures once motion captured. When you open the camera, the screen shows the number of times triggered, you can review the pictures on the screen.

The results of your testing will help you find the best placement when mounting and aiming the camera. The height away from the ground for placing the device should vary with the animal size appropriately. In general, 3 to 6 feet is preferred.

You can avoid potential false triggers due to temperature and motion disturbances in front of the camera by not aiming it at a heat source or nearby tree branches or brush (especially on windy days).

Do NOT install the camera behind the glass window as that is not possible to sense any motion. Avoid the camera toward to glass object.

### **9.3. SWITCHING ON THE CAMERA**

The camera supports two working mode “Motion Detection” and “Time Lapse”.

(1) If you set the camera working mode as “Motion detection” in the menu, once you switch to the **ON** mode, the camera countdowns 30-second delay, and then ready to capture, go into standby(surveillance). Any motion that is detected by it will trigger the capture of images as programmed in the menu. Be

sure you have read the descriptions of the Detection Delay, PIR Sensitivity parameters.

(2) If you set the camera working mode as “Time Lapse” in the menu, once you switch to the **ON** mode, the camera will be ready to go into “Time Lapse” mode, then take images periodically according to your preset “Timelapse Interval” parameter, regardless of the settings “Detection Delay”.

Before leaving the camera unattended, please check for the following:

- Are the batteries inserted with correct polarity and is their power level sufficient?
- Does the SD card have sufficient available space?
- Is the power switch in the **ON** position?

## **10. REVIEW PHOTOS OR VIDEOS**

After you have setup, mounted and activated your CAMERA, you will of course be eager to return later and review the images it has captured for you. The camera stores photos and videos in the folder \DCIM\100MEDIA in the SD card. Photos are saved with file names like DSCF0001.JPG and videos like DSCF0001.MP4. The MP4 video files can be played back on most popular media players, such as Windows Media Player, QuickTime, VLC etc.

There are several different ways this can be done.

You can directly review the photos or videos on the camera screen.

Or in the **SET** mode only, you can use the provided USB cable to download the files to a computer.

Or you can put the SD card to a SD card "reader" (*user supplied*), plug in a computer, and browse the files on the computer without downloading.

## 11. TECHNICAL SPECIFICATIONS

Element	Description
<b>Working Mode</b>	Motion detection or Time Lapse
<b>Max. Pixel Size</b>	20MP
<b>Lens</b>	F=1.6, FOV=63°, Auto IR-Cut
<b>IR Flash</b>	100ft
<b>LCD Screen</b>	2.31" Color screen
<b>Keypad</b>	6 Keys, 1 Power switch
<b>Memory</b>	SD, SDHC or SDXC Regular memory card (Not included), max capacity 128GB
<b>Picture Resolution</b>	20MP, 16MP, 8MP, 4MP, 2MP
<b>Video Resolution</b>	1080P@30fps, 720P@30fps
<b>PIR Sensitivity</b>	High/Normal/Low
<b>PIR Sensing Distance</b>	82ft (Below 77°F/25°C)
<b>PIR Sensing Angle</b>	Total 120°(while side motion sensors enabled) Central zone: 60°, Left side: 30°, Right side: 30°
<b>Trigger Time</b>	Approx. 0.1~0.6 second (0.1s while side motion sensors enabled)
<b>Trigger Interval</b>	0sec.-60min, Programmable
<b>Shooting Numbers</b>	1~5
<b>Video Length</b>	3sec ~ 5min., Programmable (Note: Max 30 seconds at night time to conserve batteries lifetime)
<b>Info Strip</b>	On /Off
<b>Operation Hours</b>	On /Off, Specific working period of time

<b>Password</b>	4-Digit Code
<b>Camera Name</b>	4-Character (A-Z, 0-9)
<b>Time Lapse</b>	1 Sec. ~ 24 Hours
<b>Power Supply</b>	8x1.5V AA Batteries (Not included)
<b>Stand-by Time</b>	8 Months
<b>Auto Stand-by</b>	Auto Stand-by (Surveillance mode) in 5 minutes while no operation in SET mode
<b>Low Battery Alarm</b>	8V - Low Battery (Batteries die) 9V - Night vision is unavailable in low voltage (Almost die)
<b>Interface</b>	Mini-USB, Regular SD card holder, External Power (DC 12V/1A, Plug 4.0x1.7mm)
<b>Mounting</b>	Strap, Tripod Base (1/4-20)
<b>Waterproof</b>	IP66
<b>Operation Temperature</b>	-4~140°F/-20~60°C
<b>Operation Humidity</b>	5% ~ 95%
<b>Certificate</b>	FCC & CE & RoHS
<b>Product Dimensions</b>	6.1 x 4.4 x 3.0 inches

## **12. WARRANTY**

### **ONE YEAR LIMITED WARRANTY**

**Your trail camera warranty covers your trail camera for one year after the original purchase date.** We warrant that your camera will be free from defects in materials and workmanship when operated in normal use and conditions. This warranty does not cover consumer caused damages such as misuse, abuse, improper handling or installation, damaged caused by wild animals, or repairs attempted by someone other than our authorized technicians.

We will, at our option during the warranty period, repair your camera or replace it with the same or comparable model free of charge. This warranty only extends to the original retail buyer from our authorized dealer. Purchase receipt, order number or other proof of the date of the original purchase is required to receive warranty benefits. The warranty on any replacement product provided under the original warranty shall be for the remaining portion of the warranty period applicable to the original product.

This warranty extends solely to failures due to defects in materials or workmanship under normal use. It does not cover normal wear of the product.

If you need to return a product under this warranty, please contact your dealer or our distributor.

### 13. FCC COMPLIANCE STATEMENT

This equipment has been tested and found to comply with the limits for a Class B digital device, pursuant to part 15 of the FCC Rules. These limits are designed to provide reasonable protection against harmful interference in a residential installation.

Operation is subject to the following two conditions: (1) This device may not cause harmful interference, and (2) this device must accept any interference received, including interference that may cause undesired operation.

This equipment generates, uses and can radiate radio frequency energy and, if not installed and used in accordance with the instructions, may cause harmful interference to radio communications. However, there is no guarantee that interference will not occur in a particular installation. If this equipment does cause harmful interference to radio or television reception, which can be determined by turning the equipment off and on, the user is encouraged to try to correct the interference by one or more of the following measures:

- Reorient or relocate the receiving antenna.
- Increase the separation between the equipment and receiver.
- Connect the equipment into an outlet on a circuit different from that to which the receiver is connected.
- Consult the dealer or an experienced radio/TV technician for help.

The device does not contain any user-serviceable parts. Repairs should only be made by an Authorized repair center. Unauthorized repairs or modifications could result in permanent damage to the equipment, and will void your warranty and your authority to operate this device under Part 15 regulations.

The shielded interface cable which is provided must be used with the equipment in order to comply with the limits for a digital device pursuant to Subpart B of Part 15 of FCC Rules.

